

## Workshop Manual

Yeti 2010 ➤

Yeti 2011 ➤

1,2/77 kW TSI engine

Engine ID	CBZ B								
-----------	----------	--	--	--	--	--	--	--	--

Protected by copyright. Copying for private or commercial purposes, in part or in whole, is not permitted unless authorized by ŠKODA AUTO A. S. ŠKODA AUTO A. S. does not guarantee or accept any liability with respect to the correctness of information in this document. Copyright by ŠKODA AUTO A. S. ©

Edition 12.2010

## List of Workshop Manual Repair Groups

# SKODA

### Repair Group

- 00 - Technical data
- 01 - Self-diagnosis
- 10 - Removing and installing engine
- 13 - Crankshaft group
- 15 - Cylinder head, valve gear
- 17 - Lubrication
- 19 - Cooling
- 20 - Fuel supply system
- 21 - Turbocharging/supercharging
- 24 - Mixture preparation - injection
- 26 - Exhaust system
- 28 - Ignition system



Protected by copyright. Copying for private or commercial purposes, in part or in whole, is not permitted unless authorised by ŠKODA AUTO A. S. ŠKODA AUTO A. S. does not guarantee or accept any liability with respect to the correctness of information in this document. Copyright by ŠKODA AUTO A. S. ©

Technical information should always be available to the foremen and mechanics, because their careful and constant adherence to the instructions is essential to ensure vehicle road-worthiness and safety. In addition, the normal basic safety precautions for working on motor vehicles must, as a matter of course, be observed.

**All rights reserved.**  
**No reproduction without prior agreement from publisher.**



## Contents

<b>00 - Technical data</b>	<b>1</b>
<b>1 Technical data</b>	<b>1</b>
1.1 Engine number	1
1.2 Engine characteristics	1
<b>01 - Self-diagnosis</b>	<b>3</b>
<b>1 Self diagnosis, safety measures, cleanliness regulations, directions</b>	<b>3</b>
1.1 Self-diagnosis	3
1.2 Regulations concerning safety precautions when working on the fuel system	3
1.3 Release pressure in the high pressure area of the fuel system	4
1.4 Rules of cleanliness to observe when working on the fuel supply system	5
1.5 Safety measures to apply when working on the fuel injection and ignition system	5
1.6 General notes on the injection system	6
1.7 General notes on the ignition system	7
1.8 General instructions for charge air system	7
1.9 Additional instructions when undertaking assembly work on the air-conditioning system	8
<b>10 - Removing and installing engine</b>	<b>9</b>
<b>1 Removing and installing engine</b>	<b>9</b>
1.1 Removing engine	9
1.2 Securing the engine to the assembly stand	15
1.3 Installing the engine	16
<b>2 Assembly bracket</b>	<b>19</b>
2.1 Unit mounting - summary of components	19
2.2 Checking and adjusting the assembly bracket	20
<b>13 - Crankshaft group</b>	<b>23</b>
<b>1 V-ribbed belt drive</b>	<b>23</b>
1.1 V-ribbed belt - Summary of components	23
1.2 Removing and installing V-ribbed belt	26
1.3 Removing and installing bracket for top auxiliary units	27
1.4 Removing and installing bracket for bottom auxiliary units	29
<b>2 Camshaft drive</b>	<b>31</b>
2.1 Camshaft drive - Summary of components	31
2.2 Removing and installing the top timing case	33
2.3 Removing and installing the bottom timing case	35
<b>3 Sealing flanges and flywheel</b>	<b>38</b>
3.1 Summary of components	38
3.2 Removing and installing flywheel	39
3.3 Replacing crankshaft seal on belt pulley side	40
3.4 Removing and installing crankshaft-belt pulley	41
3.5 Replace sealing flange on the gearbox side	44
<b>4 Crankshaft</b>	<b>50</b>
4.1 Replace needle bearing for crankshaft	50
<b>5 Pistons and conrods</b>	<b>52</b>
5.1 Summary of components	52
5.2 Inspect piston, piston rings and cylinder bore	53
5.3 Separating new conrod	55
<b>15 - Cylinder head, valve gear</b>	<b>56</b>
<b>1 Cylinder head - part 1</b>	<b>56</b>
1.1 Summary of components	56



1.2	Test timing	58
1.3	Setting the timing	60
1.4	Removing and installing timing chain and drive chain for oil pump	66
<b>2</b>	<b>Cylinder head - part 2</b>	<b>73</b>
2.1	Removing and installing cylinder head cover and camshaft	73
2.2	Removing and installing the cylinder head	81
2.3	Testing the compression	83
2.4	Testing the combustion chamber for tightness	84
<b>3</b>	<b>Valve gear</b>	<b>86</b>
3.1	Valve gear - Summary of components	86
3.2	inspect camshaft, axial play	87
3.3	Inspect valve guides	87
3.4	Replacing valve stem seals	88
<b>17</b>	<b>Lubrication</b>	<b>90</b>
<b>1</b>	<b>Lubrication system</b>	<b>90</b>
1.1	Summary of components	90
1.2	Removing and installing oil pan	93
1.3	Removing and installing oil pump	95
1.4	Removing and installing engine oil cooler	95
1.5	Testing oil pressure and oil pressure switch	96
<b>19</b>	<b>Cooling</b>	<b>98</b>
<b>1</b>	<b>Cooling system</b>	<b>98</b>
1.1	Connection diagram for coolant hoses	98
1.2	Draining and filling up coolant	99
<b>2</b>	<b>Parts of cooling system engine side</b>	<b>103</b>
2.1	Coolant regulator - Summary of components	103
2.2	Removing and installing belt pulley for coolant pump	103
2.3	Removing and installing coolant pump	104
2.4	Removing and installing coolant recirculation pump V50	105
<b>3</b>	<b>Radiator and radiator fan</b>	<b>106</b>
3.1	Parts of cooling system on the side next to the body - Summary of components	106
3.2	Removing and installing fan shroud for radiator fan V7	107
3.3	Removing and installing radiator	108
3.4	Checking the coolant system for leaktightness	109
<b>20</b>	<b>Fuel supply system</b>	<b>111</b>
<b>1</b>	<b>Fuel tank and fuel delivery unit</b>	<b>111</b>
1.1	Fuel tank for vehicles manufactured up to 06.10 - Summary of components	111
1.2	Fuel tank for vehicles manufactured as of 06.10 - Summary of components	113
1.3	Fuel filter - Summary of components	115
1.4	Extract fuel from the fuel tank	115
1.5	Removing and installing fuel tank for vehicles manufactured up to 06.10	117
1.6	Removing and installing fuel tank for vehicles manufactured as of 06.10	120
1.7	Removing and installing fuel delivery unit for vehicles manufactured up to 06.10	122
1.8	Removing and installing fuel delivery unit for vehicles manufactured as of 06.10	125
1.9	Removing and installing the sender for fuel gauge display G	127
1.10	Testing fuel pump	128
1.11	Removing and installing fuel gauge sender -2- G169 for vehicles manufactured up to 06.10	143
1.12	Removing and installing suction jet pump for vehicles manufactured up to 06.10	145
<b>2</b>	<b>Electronic Engine Power Control (Electronic throttle)</b>	<b>146</b>
2.1	Accelerator pedal module - Summary of components	146
2.2	Removing and installing accelerator pedal module	146



<b>3</b>	<b>Activated charcoal container system</b>	<b>149</b>
3.1	Activated charcoal container system - Summary of components	149
3.2	Check fuel tank ventilation	149
<b>21</b>	<b>Turbocharging/supercharging</b>	<b>152</b>
<b>1</b>	<b>Exhaust gas turbocharger</b>	<b>152</b>
1.1	Exhaust turbocharger - Summary of components	152
1.2	Removing and installing exhaust gas turbocharger	154
<b>2</b>	<b>Charge air system with exhaust gas turbocharger</b>	<b>159</b>
2.1	Charge air system - Summary of components	159
2.2	Removing and installing charge air cooler	160
<b>24</b>	<b>Mixture preparation - injection</b>	<b>162</b>
<b>1</b>	<b>Fitting location of the injection system</b>	<b>162</b>
<b>2</b>	<b>Intake manifold and fuel distributor</b>	<b>164</b>
2.1	Intake manifold - Summary of components	164
2.2	Removing and installing the throttle valve control unit J338	167
2.3	Clean throttle valve control unit J338	169
2.4	Removing and installing intake manifold	169
<b>3</b>	<b>Air filter</b>	<b>171</b>
3.1	Air filter - Summary of components	171
3.2	Removing and installing air filter	171
<b>4</b>	<b>High pressure pump</b>	<b>173</b>
4.1	High pressure pump - Summary of components	173
4.2	Removing and installing the high pressure pump	174
<b>5</b>	<b>Injection valves</b>	<b>177</b>
5.1	Removing and installing injection valves	177
5.2	Replace Teflon gasket ring and supporting washer at injection valve	179
<b>6</b>	<b>Testing components</b>	<b>183</b>
6.1	Check fuel pressure sender G247	183
<b>7</b>	<b>Engine control unit</b>	<b>186</b>
7.1	Removing and installing engine control unit	186
<b>26</b>	<b>Exhaust system</b>	<b>188</b>
<b>1</b>	<b>Removing and installing parts of the exhaust system</b>	<b>188</b>
1.1	Catalytic converter and component parts - Summary of components	188
1.2	Middle and rear silencer for vehicles manufactured up to 06.10 - Summary of components	190
1.3	Middle and rear silencer for vehicles manufactured as of 06.10 - Summary of components	191
1.4	Replacing middle or rear silencer	191
1.5	Aligning exhaust system free of stress	192
1.6	Inspecting the exhaust system for leaktightness	193
<b>28</b>	<b>Ignition system</b>	<b>195</b>
<b>1</b>	<b>Ignition system</b>	<b>195</b>
1.1	Ignition system - Summary of components	195
1.2	Removing and installing engine speed sender G28	196



# ŠKODA



Protected by copyright. Copying for private or commercial purposes, in part or in whole, is not permitted unless authorised by ŠKODA AUTO A. S. ŠKODA AUTO A. S. does not guarantee or accept any liability with respect to the correctness of information in this document. Copyright by ŠKODA AUTO A. S. ©



## 00 – Technical data

### 1 Technical data

#### 1.1 Engine number

The engine number („engine identification character“ and „serial number“) is located on the engine closely above the connection of the engine with the gearbox.

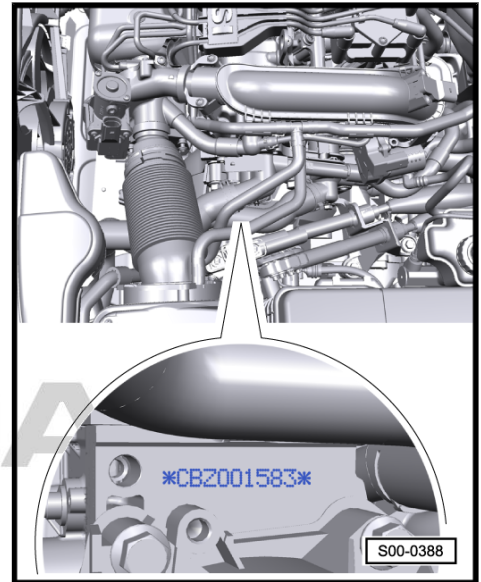

In addition, the „engine identification character“ and the „serial number“ are indicated on the vehicle data sticker -arrow- which is located on the air guide pipe.

- ◆ The engine identification characters have 4 digits starting with the letter „C“.
- ◆ The first 3 digits of the engine identification characters refer to the displacement and the mechanical construction of the engine. They are type-punched in the cylinder block including the serial number.
- ◆ The 4th digit refers to the output and torque of the engine and depends upon the engine control unit.

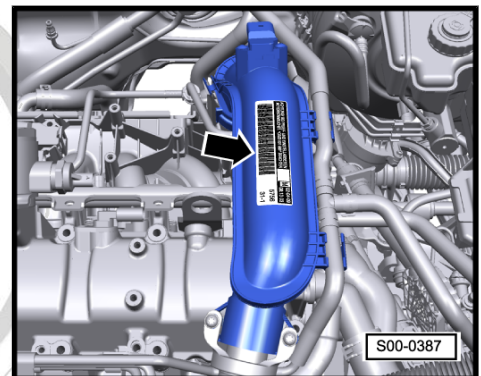

#### 1.2 Engine characteristics

Engine identification characters		CBZB
Manufactured		09.09 ►
Exhaust limit values conforming to		EU5
Displacement	cm <sup>3</sup>	1197
Power output	kW at rpm	77/5000
Torque	Nm at rpm	175/1500-3500
Bore	∅ mm	71,0
Stroke	mm	75,6
Compression ratio		10:1
Cylinder / valves per cylinder		4 / 2
RON		unleaded 95 <sup>1)</sup>
Ignition system, fuel injection		Simos 10
Type of fuel preparation		Direct injection homogeneous
Knock control		1 sensor



Engine identification characters	CBZB
Lambda control	2 Lambda probes
Three-way catalytic converter	yes
Exhaust gas recirculation	no
Intake manifold change-over	no
Camshaft adjustment	no
Secondary air system	no
Exhaust gas turbocharger	yes
Balancing shaft	no

1) At least 91 RON in exceptional cases, although engine output is reduced

# ŠKODA



Protected by copyright. Copying for private or commercial purposes, in part or in whole, is not permitted unless authorised by ŠKODA AUTO A. S. ŠKODA AUTO A. S. does not guarantee or accept any liability with respect to the correctness of information in this document. Copyright by ŠKODA AUTO A. S. ©

## 01 – Self-diagnosis

### 1 Self diagnosis, safety measures, cleanliness regulations, directions

#### 1.1 Self-diagnosis

This Rep.-Gr. is deleted.

For this use the „Vehicle self-diagnosis“, „Measuring method“ and „Fault finding“ ⇒ Vehicle diagnostic, testing and information system VAS 5051.

#### 1.2 Regulations concerning safety precautions when working on the fuel system



##### WARNING

- ◆ *The safety measures for the pressure reduction in the high pressure area of the fuel system must be observed ⇒ [page 4](#).*
- ◆ *The fuel system is under pressure! Wear safety goggles and safety clothing, in order to avoid injuries and skin contact with fuel. Place a clean cleaning cloth around the connection point before detaching wiring. Reduce pressure by carefully removing the wiring.*

Protected by copyright. Copying for private or commercial purposes, in part or in whole, is not permitted. ŠKODA AUTO A. S. does not guarantee or accept any liability for the content. Copyright by ŠKODA AUTO A. S.



- ◆ The fuel delivery unit is activated when the ignition is switched on and by the door contact switch of the driver door. For reasons of safety, if the battery is not disconnected, the plug -3- must be disconnected from the fuel pump control unit -1- before opening the fuel system.



### Caution

**When undertaking all assembly work, particularly in the engine compartment due to its cramped construction, please observe the following:**

- ◆ Lay lines of all kinds (e.g. for fuel, hydraulic fluid, cooling fluid and refrigerant, brake fluid, vacuum) and electrical lines in such a way that the original line guide is re-established.
- ◆ In order to avoid damage to the cables, ensure that there is adequate free access to all moving or hot components.

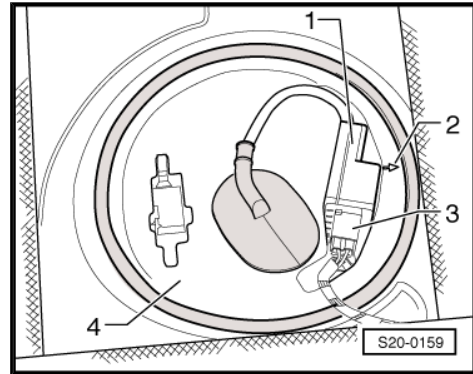

When removing and installing the fuel gauge sender or the fuel delivery unit from a full or partly filled fuel tank, pay attention to the following points:

- ◆ The extraction hose of an exhaust extraction system which is switched on, must be positioned close to the assembly opening of the fuel tank in order to extract the released fuel vapours, even before the work is commenced. If no exhaust extraction system is available, a radial fan (motor not in air flow of fan) with a delivery volume above 15 m<sup>3</sup>/h must be used.
- ◆ Avoid skin contact with fuel!
- ◆ Wear fuel-resistant gloves!

## 1.3 Release pressure in the high pressure area of the fuel system



### WARNING

- ◆ The injection system consists of a high pressure part (max. pressure of 12 MPa = 120 bar) and a low pressure part (pressure of approx. 0.6 MPa = 6 bar).
- ◆ Before opening the high pressure area, e.g. removing the high pressure pump, the fuel distributor, the injection valves, the fuel pipes or the fuel pressure sender -G247-, the fuel pressure in the high pressure area with a remaining pressure of approx. 0.6 MPa (6 bar) must be reduced. The procedure for this is described below.

- Connect the ⇒ Vehicle diagnostic, testing and information system VAS 5051 and carry out the targeted function „remove high fuel pressure“.
- Switch off ignition.



- For safety reasons before opening the fuel system disconnect the plug from the fuel pump control unit -3-.

**WARNING**

*The fuel lines are pressurized! Wear safety goggles and safety clothing, in order to avoid injuries and skin contact with fuel. Before opening the high pressure part lay cleaning cloths around the connection point.*

- Now lay a clean cleaning cloth around the connection point and carefully open it up, in order to reduce the remaining pressure of approx 0.6 MPa (6 bar). Collect the fuel which flows out.

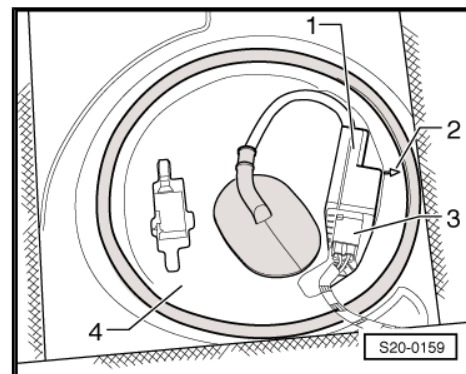
**Note**

- ◆ Interrogate the fault memory of the engine control unit at the end of the following work and delete all the fault entries.
- ◆ If the fault memory was erased, the readiness code must be generated → Vehicle diagnostic, testing and information system VAS 5051.

## 1.4 Rules of cleanliness to observe when working on the fuel supply system

Carefully observe the following five rules for cleanliness when working on the fuel supply/injection system:

- ◆ Thoroughly clean the connection points and their surroundings before releasing.
- ◆ Place removed parts on a clean surface and cover. Do not use fuzzy cloths!
- ◆ Carefully cover or close opened components if the repair is not completed immediately.
- ◆ Only install clean parts: Remove spare parts from their wrapping immediately before installing. Do not use any parts which have been stored unwrapped (e.g. in tool boxes).
- ◆ When the system is opened: Avoid using compressed air. Avoid moving the vehicle.

## 1.5 Safety measures to apply when working on the fuel injection and ignition system

**WARNING**

- ◆ *The safety measures for the pressure reduction in the high pressure area of the fuel system must be observed ⇒ page 4 .*
- ◆ *The fuel system is under pressure! Wear safety goggles and safety clothing, in order to avoid injuries and skin contact with fuel. Place a clean cleaning cloth around the connection point before detaching wiring. Reduce pressure by carefully removing the wiring.*

Protected by copyright. Copying for private or commercial purposes, in part or in whole, is not permitted unless authorised by ŠKODA AUTO A. S. ŠKODA AUTO A. S. does not guarantee or accept any liability with respect to the correctness of information in this document. Copyright by ŠKODA AUTO A. S. ©

Observe the following points to prevent injury to persons and/or damage to the injection and ignition system:



- ◆ Do not touch or remove ignition leads and ignition coils with power output stages with the engine running or at start speed.
- ◆ Ignition must be switched off before disconnecting and re-connecting the cables of the fuel injection and the ignition system as well as of the test equipment.
- ◆ If the engine must be operated at start speed without the engine starting, as for example, when checking the compression pressure, open lid of fuse carrier in the engine compartment and unplug fuse for Motronic current supply relay -J271-  
⇒ Current flow diagrams, Electrical fault finding and Fitting locations.
- ◆ The fuel delivery unit is activated when the ignition is switched on and by the door contact switch of the driver door. Before opening the fuel system and for reasons of safety, if the battery is not disconnected, the plug -3- must be disconnected from the fuel pump control unit.



### Caution

***When undertaking all assembly work, particularly in the engine compartment due to its cramped construction, please observe the following:***

- ◆ ***Lay lines of all kinds (e.g. for fuel, hydraulic fluid, the active charcoal container-unit, cooling fluid and refrigerant, brake fluid, vacuum) and electrical lines in such a way that the original line guide is re-established.***
- ◆ ***In order to avoid damage to the cables, ensure that there is adequate free access to all moving or hot components.***

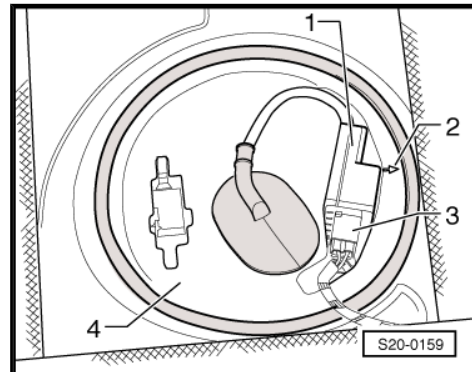

If test and measuring devices are required during test drives observe the following:

- ◆ Always secure the test and measuring devices on the rear seat and have a second person operate them there.
- ◆ If the test and measuring devices are operated from the passenger seat, the passenger can be injured by the release of the passenger airbag in the event of an accident.

## 1.6 General notes on the injection system

Repairing ignition ⇒ [page 195](#) .

- ◆ The engine control unit is equipped with self-diagnosis. Before repairs and also for fault finding, first of all interrogate the fault memory. Also check the vacuum hoses and connections (unmetered air).
- ◆ Fuel hoses in the engine compartment must only be secured with spring-type clips ⇒ electronic catalogue of original parts . The use of clamp-type or screw-type clips is not allowed.
- ◆ A minimum voltage of 11.5 V is required for perfect functioning of the electrical components.
- ◆ Do not use sealants containing silicone. Traces of silicone elements drawn in by the engine are not burnt in the engine and damage the lambda probe.
- ◆ If after fault finding, repair or inspection of components the engine starts briefly and then stops, it is possible that the immobiliser blocks the engine control unit. Then if necessary the control unit must be adapted ⇒ Vehicle diagnostic, testing and information system VAS 5051.

Copyright. Copying for private or commercial purposes, in part or in whole, is not permitted unless authorised by ŠKODA AUTO A. S. ŠKODA AUTO A. S. does not guarantee or accept any liability with respect to the correctness of information in this document. Copyright by ŠKODA AUTO A. S.®

- ◆ When opening the driver door the fuel pump is activated for 2 seconds in order to build up the pressure in the fuel system.
- ◆ Certain inspections may cause the control unit to detect and store a fault. It is therefore necessary to interrogate the fault memory after having completed all inspections and repairs, and if necessary delete ⇒ Vehicle diagnostic, testing and information system VAS 5051.

Safety measures ⇒ [page 5](#) .

## 1.7 General notes on the ignition system

- ◆ Switch off the ignition before disconnecting and connecting the battery, as this may damage the 4AV control unit.
- ◆ The engine control unit is equipped with self-diagnosis; inspect ⇒ Vehicle diagnostic, testing and information system VAS 5051.
- ◆ A minimum voltage of 11.5 V is required for perfect functioning of the electrical components.
- ◆ Certain inspections may cause the control unit to detect and store a fault. It is therefore necessary to interrogate the fault memory after having completed all inspections and repairs, and if necessary delete ⇒ Vehicle diagnostic, testing and information system VAS 5051.
- ◆ If after fault finding, repair or inspection of components the engine starts briefly and then stops, it is possible that the immobiliser blocks the engine control unit. Then if necessary the control unit must be adapted ⇒ Vehicle diagnostic, testing and information system VAS 5051.

Safety measures ⇒ [page 5](#) .

Setting data, spark plugs ⇒ Maintenance ; Booklet Yeti .

## 1.8 General instructions for charge air system



### WARNING

*When undertaking all assembly work, particularly in the engine compartment due to its cramped construction, please observe the following:*

- ◆ *Lay lines of all kinds (e.g. for fuel, hydraulic fluid, cooling fluid and refrigerant, brake fluid, vacuum) and electrical lines in such a way that the original line guide is re-established.*
- ◆ *Ensure that there is adequate free access to all moving or hot components.*

**Caution**

*In case a mechanical damage to the exhaust gas turbocharger is found, e.g. damage to the compressor wheel, it is not sufficient to only replace the turbocharger. In order to avoid consequential damage, perform the following tasks:*

- ◆ *Clean all oil lines.*
- ◆ *Change engine oil and oil filter.*
- ◆ *Inspect the air filter housing, the air filter element and the intake hoses for contaminations.*
- ◆ *Inspect the whole charge-air routing and the charge air cooler for foreign bodies.*

*If foreign bodies are detected in the charge air system, the complete charge-air routing must be cleaned and if necessary the charge air cooler must also be replaced.*

- ◆ The charge-air system must be tight.
- ◆ Always replace self-locking nuts.
- ◆ Hose connections and hoses of the charge air system must be free of oil and grease before being installed.
- ◆ Only use approved clamps for securing the hose connections  
⇒ Electronic Catalogue of Original Parts .
- ◆ Use pliers for spring strap clamps to fit the spring strap clips.
- ◆ Before connecting the oil feed line, fill the exhaust turbocharger via the connection fitting with engine oil.
- ◆ After installing the turbocharger, run engine at idling speed for about 1 minute to ensure that oil is supplied to the turbocharger.

## 1.9 Additional instructions when undertaking assembly work on the air-conditioning system

**WARNING**

*Do not open the refrigerant circuit of the air conditioning system.*

**Note**

*In order to avoid damage to the condenser as well as to the refrigerant lines and hoses, ensure that the lines and hoses are not over-tensioned, kinked or bent.*

Steps which should be taken in order to remove and install the engine without opening the refrigerant circuit:

- Remove the holding clamp(s) of the refrigerant lines.
- Remove AC compressor from the bracket ⇒ [page 23](#) .
- Mount the AC compressor in such a way that the refrigerant lines/hoses are not under tension.

## 10 – Removing and installing engine

### 1 Removing and installing engine

#### 1.1 Removing engine

##### Special tools and workshop equipment required

- ◆ Engine/gearbox jack , e.g. -V.A.G 1383 A-
- ◆ Double ladder , e. g. -VAS 5085-
- ◆ Engine mount -T10416-
- ◆ Pliers for spring strap clamps
- ◆ Catch pan e.g. -VAS 6208-

##### Note

- ◆ *The engine is removed downwards together with the gearbox.*
- ◆ *All cable straps that have been loosened or cut open when the engine was removed must be attached again in the same location when the engine is installed again.*
- ◆ *Leave the ignition key in the ignition lock so that the steering lock does not click into place.*
- ◆ *Collect drained coolant in a clean container for reuse or proper disposal.*

##### Caution

*When undertaking all assembly work, particularly in the engine compartment due to its cramped construction, please observe the following:*

- ◆ *Lay lines of all kinds (e.g. for fuel, hydraulic fluid, the active charcoal container-unit, cooling fluid and refrigerant, brake fluid, vacuum) and electrical lines in such a way that the original line guide is re-established.*
- ◆ *In order to avoid damage to the cables, ensure that there is adequate free access to all moving or hot components.*

Observe all safety measures and notes for assembly work on the fuel, injection and ignition system and the charge air system as well as rules for cleanliness ⇒ [page 3](#) .

##### WARNING

*Release pressure in the high pressure area of the fuel system ⇒ [page 4](#) .*

- Remove air filter ⇒ [page 171](#) .
- Before disconnecting the battery, if necessary remove the adapter for the anti-theft wheel bolts from the luggage compartment.



- Remove battery and battery tray ⇒ Electrical System ⇒ Rep. gr. 27 .
- Remove the right and left wheelhouse liner ⇒ Body Work ⇒ Rep. gr. 66 .
- Remove noise insulation ⇒ Body Work ⇒ Rep. gr. 50 .
- Drain the coolant from the engine cooling system ⇒ [page 99](#) .
- Remove right drive shaft ⇒ Chassis ⇒ Rep. gr. 40 .
- Unscrew the left drive shaft from the flange shaft of the gear-box.
- Unscrew the nut from the left coupling rod -2- and press off the coupling rod from the anti-roll bar.
- Unscrew the nuts from the left steering joint -3- and press the steering joint out of the suspension arm.

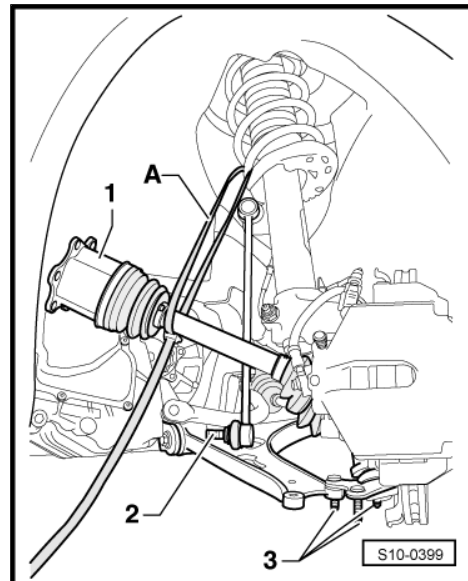

- Unscrew the nut -2- from the left track control arm if the front left vehicle level sensor -G78- is present.
- Turn steering to full left lock.
- Swivel the steering joint outwards and secure the drive shaft -1- with strap -A- in the wheelhouse.

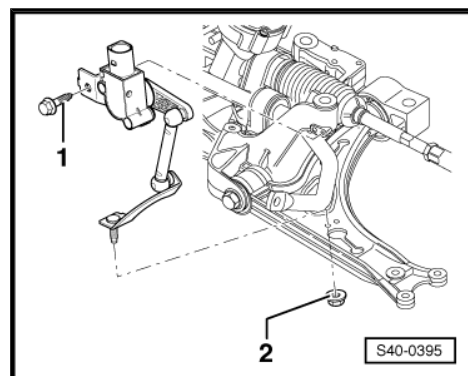

- Pull off top coolant hose -2- and bottom coolant hose from expansion reservoir.
- Disconnect the fuel feed line -3- (press in the securing ring to the top) and catch the fuel which flows out with a cleaning cloth.
- Detach the connecting hose -4- to the activated charcoal filter system.

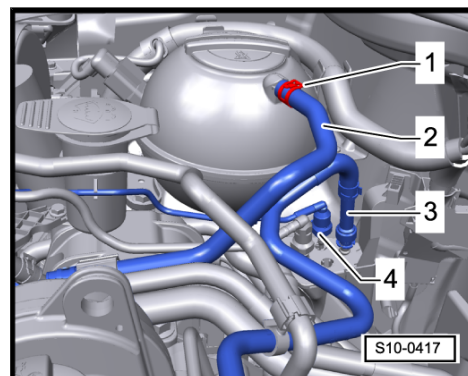



- Remove the hose -1- from the activated charcoal filter and from the activated charcoal filter solenoid valve 1 -N80- .
- Remove activated charcoal filter -2-.
- Slacken the clamp -4- and detach the coolant hose -3- from the engine.

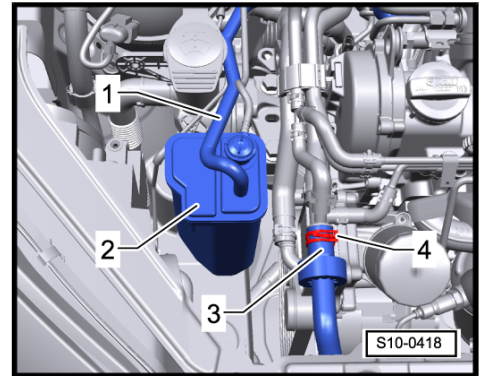

- Release the coolant hoses at the heat exchanger -arrows- and pull them off.

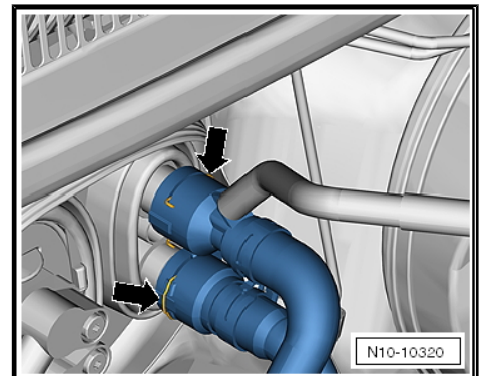

- Detach vacuum hose -1- from intake manifold.
- Slacken clamps -2- and detach coolant hoses -3 ... 5-.

**For models with automatic gearbox**

- Remove the selector lever control cable from the gearbox => Gearbox => Rep. gr. 34 .

**For vehicles with manual gearbox**

- Remove shift mechanism from gearbox => gearbox => Rep. gr. 34 .
- Remove hydraulic clutch control from gearbox => Gearbox => Rep. gr. 34 .

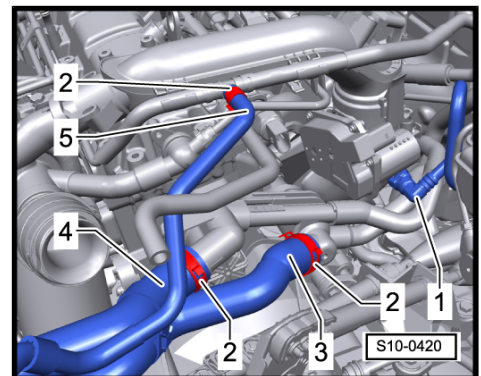

 **WARNING**

*After removing the slave cylinder or after separating the hydraulic line, do not depress the clutch pedal.*

- Disconnect all electrical lines from the gearbox, generator and starter motor and uncover them.
- Remove/unclamp all other necessary electrical cables from the engine.
- Disconnect the vacuum and bleeder hoses from the engine.
- Disconnect the plug from the thermal switch and the radiator fan.

Protected by copyright. Copying for private or commercial purposes, in part or in whole, is not permitted unless authorized in writing by SKODA AUTO A. S. © SKODA AUTO A. S. 2010  
Disconnect the plug of the engine wiring harness from the engine control unit (front plug) => [page 186](#)



- Release guide for engine wiring harness and pull out upwards -arrow-.

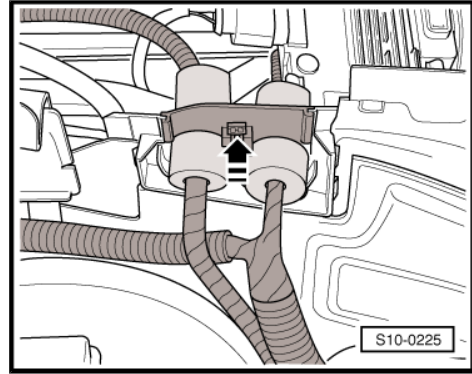

- Open all fuses for the engine wiring harness at frame side rail -arrows-.
- Open other attachments of the engine wiring harness, remove engine wiring harness and attach to engine.
- Attach the cables with a cable strap at the engine.

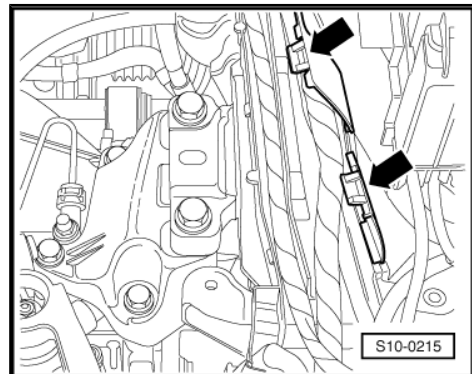

- Disconnect plugs -1 and 2-.
- Remove pre-exhaust pipe Pos. 9 ⇒ [page 188](#) .

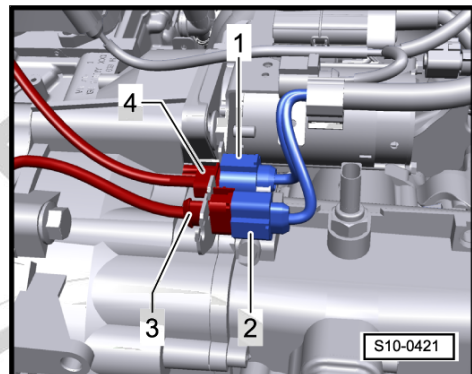

- Unscrew the screw -2- and remove the bottom coolant pipe -1-.

**Vehicles with auxiliary heating.**

- Slacken clamps -3- and pull off the coolant hoses -4 and 5-.

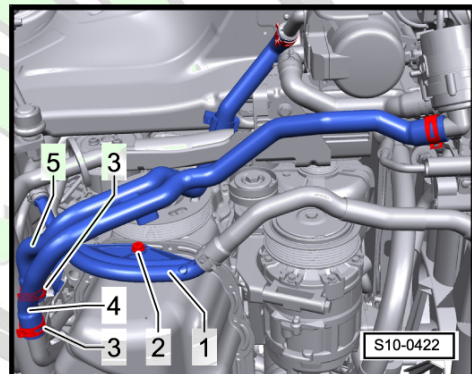

Protected by copyright. Copying for private or commercial purposes, in part or in whole, is not permitted unless authorised by ŠKODA AUTO A. S. ŠKODA AUTO A. S. does not guarantee or accept any liability with respect to the correctness of information in this document. Copyright by ŠKODA AUTO A. S. ©

- Unscrew the screws -1 and 2- of the brackets for the coolant pipes for the auxiliary heating -3-.

Continued for all vehicles

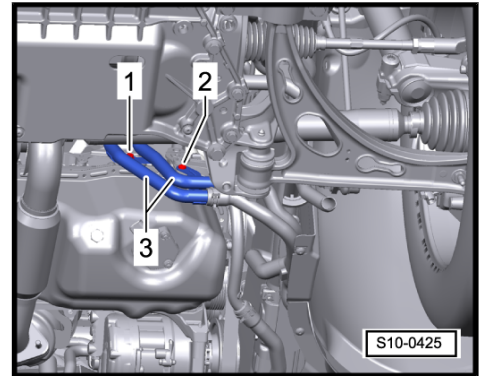

- Disconnect plug -2- from oil level and oil temperature sender -G266- .
- Remove the hold-down device for the cable guide of the oil level and oil temperature sender -G266- from the assembly carrier at the front and place down on the assembly carrier.

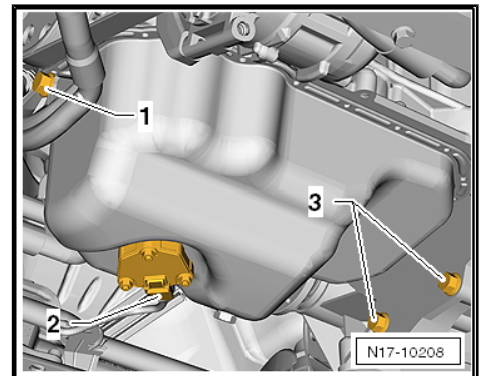

- Unscrew the pendulum support -arrows-.

For vehicles with air conditioning

- Remove V-ribbed belt => [page 26](#) .

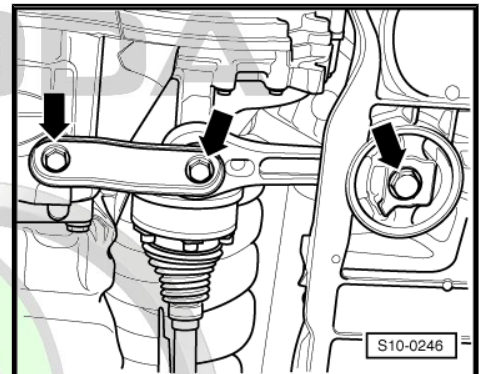



- Disconnect connector -1- for magnetic coupling at AC compressor.



**WARNING**

*Risk of injury through refrigerant.*

- ◆ *Do not open the refrigerant circuit of the air conditioning system.*



**Caution**

*Risk of damaging refrigerant lines and hoses.*

- ◆ *Do not over-tension or buckle refrigerant lines and hoses.*

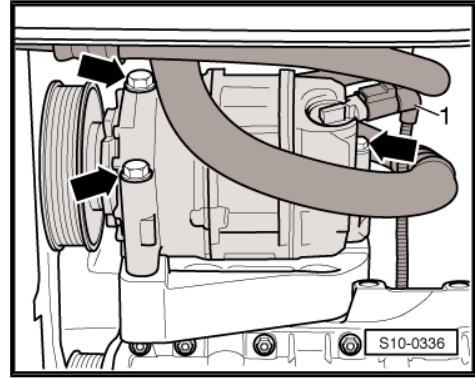

- Release screws -arrows- for AC compressor.
- Attach AC compressor to lock carrier.

**Continued for all vehicles**

In order to lower the engine with the gearbox, the engine mount -T10416- with the adapters -/1-, -/2- and -/3- is required.

ŠKODA

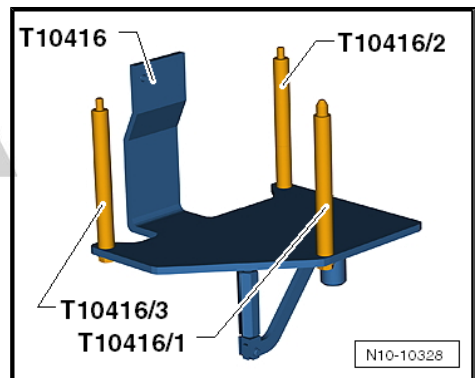

- Turn the adapter T10416/1 up to the stop in the cylinder block.

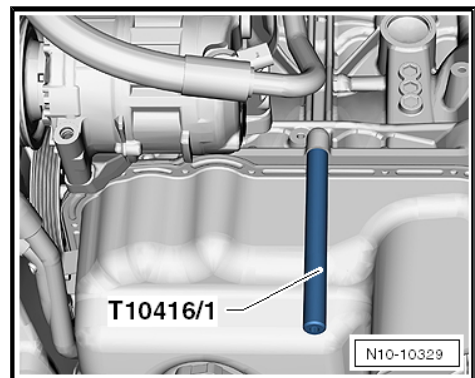

Protected by copyright. Copying for private or commercial purposes, in part or in whole, is not permitted unless authorised by ŠKODA AUTO A. S. ŠKODA AUTO A. S. does not guarantee or accept any liability with respect to the correctness of information in this document. Copyright by ŠKODA AUTO A. S. ©



- Fit the engine mount -T10416- with the adapters -/2- and -/3- to the cylinder block.
- Attach the engine mount -T10416- with the screw -1- by hand at the cylinder block.
- Tighten all screws on the engine mount -T10416- to 20 Nm.
- Place the engine/gearbox jack - V.A.G 1383 A- on the engine mount -T10416- and slightly raise the engine with the gearbox.

**Note**

- ◆ Check whether all hose and line connections between engine, gearbox and body are released, if necessary release them.
  - ◆ Use the double ladder -VAS 5085- for removing the fixing bolts.
- Release the screws -2- of the assembly bracket at the engine.

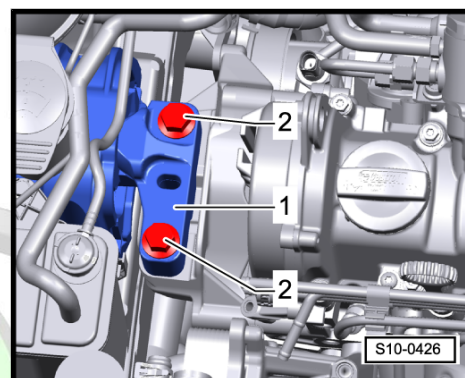
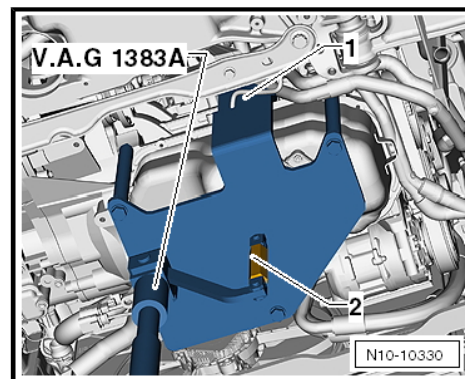

- Release the screws -2- of the assembly bracket at the gearbox.

**Note**

- ◆ The engine/gearbox assembly should be lowered with the help of a second mechanic.
  - ◆ When lowering carefully guide the engine/gearbox assembly, in order to avoid damage.
- Pull engine/gearbox unit as far forward as possible and lower carefully and slowly downwards.
- Remove the gearbox from the engine ⇒ gearbox ⇒ Rep. gr. 34 .

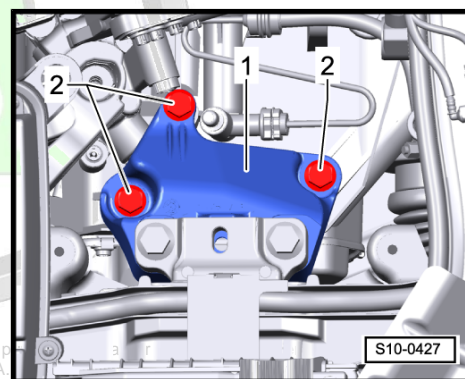

## 1.2 Securing the engine to the assembly stand

### Special tools and workshop equipment required

- ◆ Lifting device -MP 9-201 (2024 A)-
- ◆ Engine mount -MP 1-202-
- ◆ Assembly stand -MP 9-101-
- ◆ Adapter -MP1-202/8-
- ◆ Adapter -MP1-202/9-
- ◆ Workshop crane , e.g. -VAS 6100-



**Work procedure**

- Separate engine from gearbox.
- Attach the lifting device -MP9-201 (2024 A)- at the workshop crane (e.g. -VAS 6100- ) and at the engine, as shown in the figure. (The figure shows the 1.4 ltr./90 kW TSI Engine; the fixing system is identical).

**⚠ WARNING**

*Use securing pins on the hooks and rig pins to prevent release.*

*Use securing pins on the hooks and rig pins -arrows-, in order to avoid injuries and damages to the engine.*

- Lift off engine with installed engine mount -T10416- with workshop crane (e.g. -VAS 6100- ) from engine/gearbox jack -V.A.G 1383 A- .
- Remove engine mount -T10416- .
- Screw engine mount -MP 1-202- with adapters -MP1-202/8- and -MP1-202/9- to engine -arrows- and secure to the assembly stand -MP 9-101- .

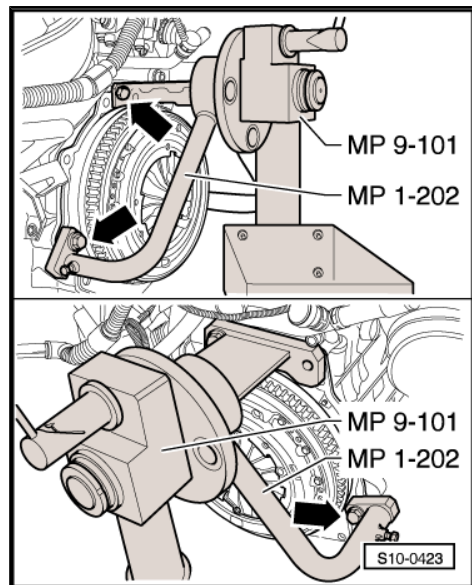
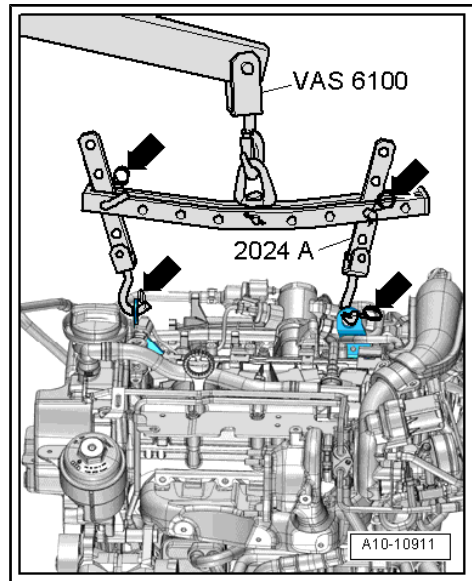

**1.3 Installing the engine**

Protected by copyright. Copying for private or commercial purposes, in part or in whole, is not permitted unless authorised by ŠKODA AUTO A. S. ŠKODA AUTO A. S. does not guarantee or accept any liability for errors. Copyright by ŠKODA AUTO A. S. ©

**Special tools and workshop equipment required**

- ◆ Double ladder , e. g. -VAS 5085-
- ◆ Catch pan for workshop crane , e.g. -VAS 6208-
- ◆ Pliers for spring strap clamps
- ◆ Grease -G 000 100-
- ◆ Cable strap

**Precondition**

- Fit engine and gearbox using engine mount -T10416- to the engine/gearbox jack -V.A.G 1383 A- .

**Work procedure**

Installation is carried out in the reverse order. Pay attention to the following:



### Caution

*When undertaking all assembly work, particularly in the engine compartment due to its cramped construction, please observe the following:*

- ◆ *Lay lines of all kinds (e.g. for fuel, hydraulic fluid, the active charcoal container-unit, cooling fluid and refrigerant, brake fluid, vacuum) and electrical lines in such a way that the original line guide is re-established.*
- ◆ *In order to avoid damage to the cables, ensure that there is adequate free access to all moving or hot components.*



### Note

- ◆ *All cable straps should be fastened again in the same place when installing.*
- ◆ *Secure all hose connections with hose clamps ⇒ Electronic Catalogue of Original Parts .*
- ◆ *Replace the self-locking nuts and screws when undertaking assembly work.*
- ◆ *Replace screws which have been tightened to a torquing angle as well as gasket rings and seals.*

Observe all safety measures and notes for assembly work on the fuel, injection and ignition system and the charge air system as well as rules for cleanliness ⇒ [page 3](#) .

- Clean the serration of the drive shaft and if the clutch disc has been used clean the hub serration, remove corrosion and only apply a very thin layer of grease -G 000 100- to the serration of the drive shaft. Subsequently move the clutch disc up and down on the drive shaft until the hub fits smoothly on the shaft. Always remove excess grease.
- After installing the coupling, check the centering of the clutch disc ⇒ gearbox ⇒ Rep. gr. 30 .
- Check the clutch release bearing for wear. Replace release bearing if worn ⇒ gearbox ⇒ Rep. gr. 30 .
- Check whether the dowel sleeves for centering the engine/ gearbox are present in the cylinder block; insert if necessary.



- Ensure that the intermediate plate has been inserted on the sealing flange and is pushed onto the dowel sleeves -arrows-.
- Screw on gearbox to engine ⇒ gearbox ⇒ Rep. gr. 34 .
- When installing the engine/gearbox assembly, ensure clearance to the assembly carrier, AC compressor as well as to the radiator fans.
- Tighten the new screws by hand for attaching the engine/gearbox assembly at the engine and gearbox mounts.
- Adjust assembly bracket ⇒ [page 20](#) and tighten screws ⇒ [page 19](#) .
- Install pendulum support ⇒ [page 19](#) .
- Install drive shafts ⇒ Chassis ⇒ Rep. gr. 40 .

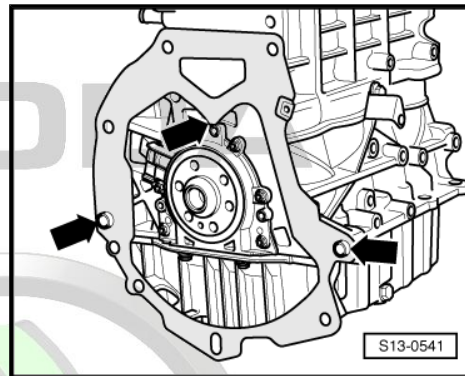

**For vehicles with air conditioning**

- Install AC compressor ⇒ [page 23](#) .
- Install the V-ribbed belt ⇒ [page 26](#) .

**Continued for all vehicles**

- Install slave cylinder ⇒ Gearbox ⇒ Rep. gr. 30 .
- Attach shift mechanism and adjust if necessary ⇒ Gearbox ⇒ Rep. gr. 34 .
- Install the engine wiring harness and connect to the engine control unit ⇒ [page 186](#) .
- Install exhaust system ⇒ [page 188](#) .
- Install the battery and pay attention to the necessary work after re-connecting the battery ⇒ Electrical System ⇒ Rep. gr. 27 .
- Checking the oil level ⇒ Maintenance ; Booklet Yeti .
- Top up and bleed cooling system ⇒ [page 99](#) .
- Interrogate all fault memories and delete all fault entries, which are caused by removing and installing the engine ⇒ Vehicle diagnostic, testing and information system VAS 5051.

After deleting the fault memory of the engine control unit the readiness code must be re-generated.

- Perform a test drive.
- Then perform a vehicle system test and if necessary eliminate the resulting faults.

**Tightening torques**

Component		Nm
Screws and nuts	M6	10
	M7	13
	M8	20
	M10	45
	M12	60
deviations:		
Engine/gearbox connecting screws ⇒ gearbox ⇒ Rep. gr. 34		
Screws for assembly bracket ⇒ <a href="#">page 19</a>		

... or commercial purposes, in part or in whole, is not permitted unless authorised by ŠKODA AUTO A. S. ŠKODA AUTO A. S. does not guarantee or accept any liability with respect to the correctness of information in this document. Copyright by ŠKODA AUTO A. S. ©

## 2 Assembly bracket

### 2.1 Unit mounting - summary of components

#### 1 - Gearbox support bracket

#### 2 - Screw

- Tightening torque ⇒ gearbox ⇒ Rep. gr. 34

#### 3 - Engine mounting

#### 4 - 40 Nm + torque a further 90° (1/4 turn)

- replace

#### 5 - Bracket for activated charcoal filter

#### 6 - 9 Nm

#### 7 - 9 Nm

#### 8 - 20 Nm + torque a further 90° (1/4 turn)

- replace

#### 9 - 20 Nm + torque a further 90° (1/4 turn)

- replace

#### 10 - Connecting part

#### 11 - 40 Nm + torque a further 90° (1/4 turn)

- replace

#### 12 - 60 Nm + torque a further 90° (1/4 turn)

- replace

#### 13 - Pendulum support

- removing: First remove screw -14-, then screws -15-.

- installing: First tighten screws -15-, then screw -14-.

#### 14 - 100 Nm + torque a further 90° (1/4 turn)

- replace

#### 15 - Screws

- replace

- Strength category 8,8: 40 Nm + torque a further 90° (1/4 turn).

- Strength category 10,9: 50 Nm + torque a further 90° (1/4 turn).

#### 16 - 60 Nm + torque a further 90° (1/4 turn)

- replace

#### 17 - 40 Nm + torque a further 90° (1/4 turn)

- replace

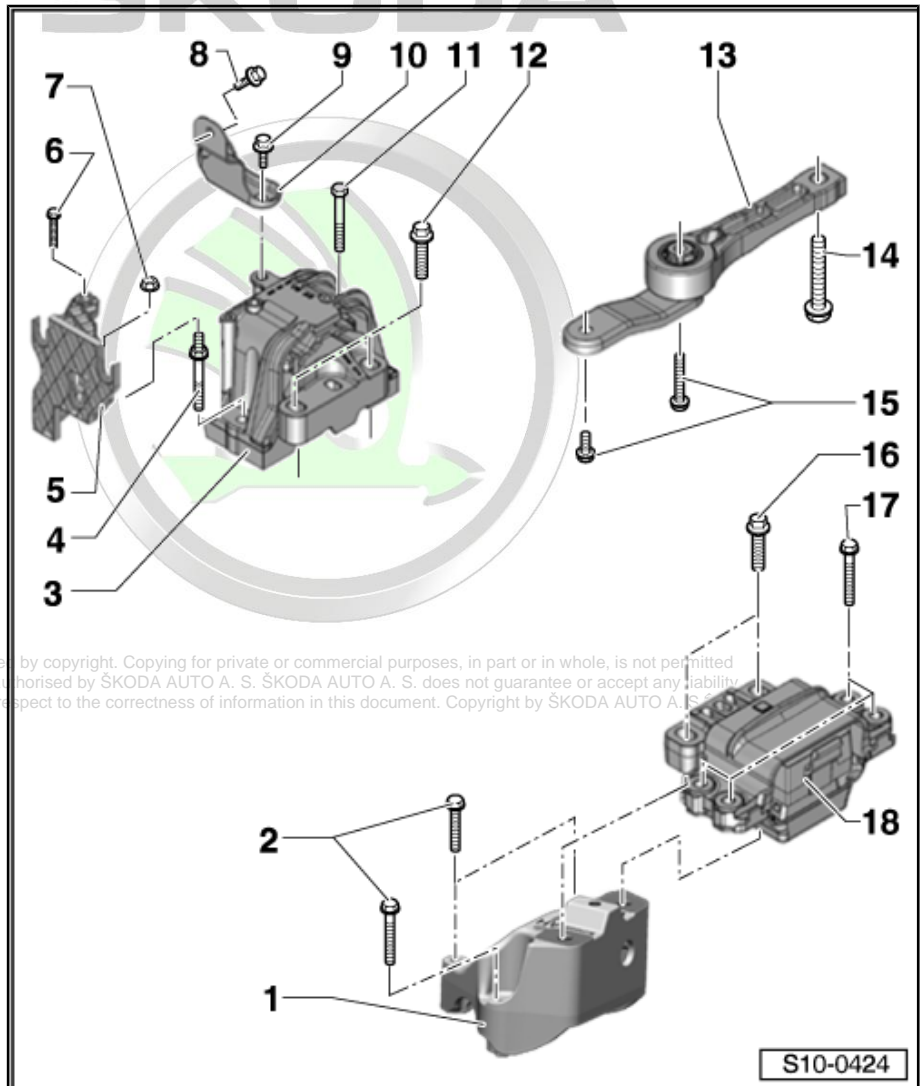



## 18 - Gearbox mount

### 2.2 Checking and adjusting the assembly bracket

#### 2.2.1 Checking the assembly bracket

- Check dimensions on the right hanger for engine/gearbox unit:
- Between engine bracket and engine support there must be a distance -a- = 10 mm.
- The cast iron edge on the engine support -2- must be parallel to the supporting arm -1- the dimension -x- must be the same at the front and rear.



#### Note

The distance -a- can also be checked e.g. with suitable round bars.

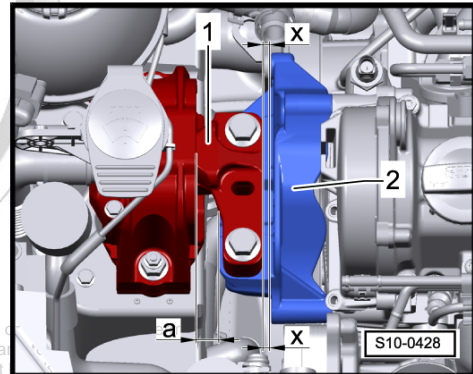

Only if there is an acoustic complaint (engine or gearbox knock on the frame side rail when cornering) and the dimension -a- is not 10 mm:

- Adjust the assembly bracket ⇒ [page 20](#) .

#### 2.2.2 Adjusting the unit mounting

##### Special tools and workshop equipment required

- ◆ Supporting device -T30099-
- ◆ Surface -T30099/1-
- ◆ Adapter -MP9-200/3 (10-222A/3)-
- ◆ Lifting eye -10-222A/12-
- ◆ Snap hook
- Remove battery and battery tray ⇒ Electrical System ⇒ Rep. gr. 27 .
- Remove the cooling water tank cover ⇒ Body Work ⇒ Rep. gr. 66 .



- Install supporting device -T30099- and support engine in fitting position. The figure shows the version with the 1.4 ltr./90 kW TSI Engine; the hanger is identical.
- Uniformly pre-tension the engine/gearbox unit with both spindles, but do not raise.

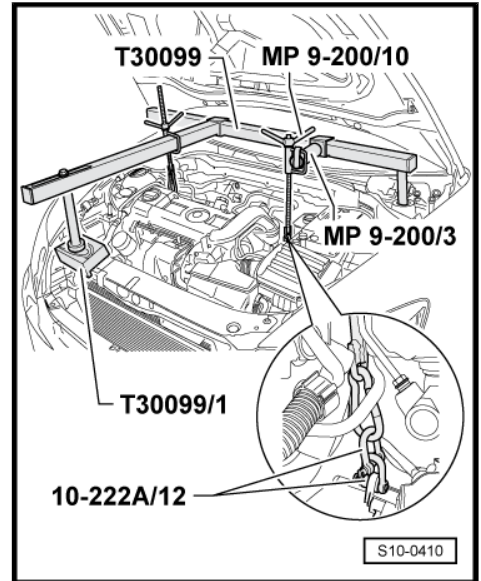

- Release the screws -2- of the assembly bracket at the engine.

ŠKODA

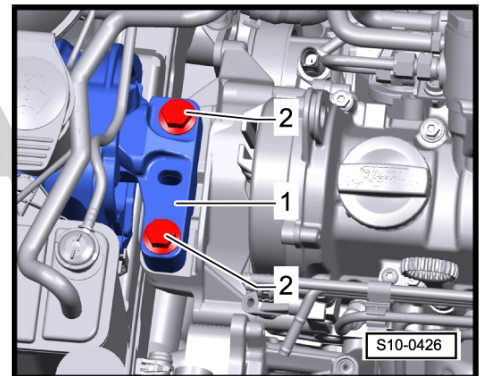

- Slightly loosen the screws -2- of the unit mounting at the gearbox (less than 1 revolution).
- Successively replace all the screws of the assembly bracket (as long as it has not already been performed when installing the engine) and insert these loosely.

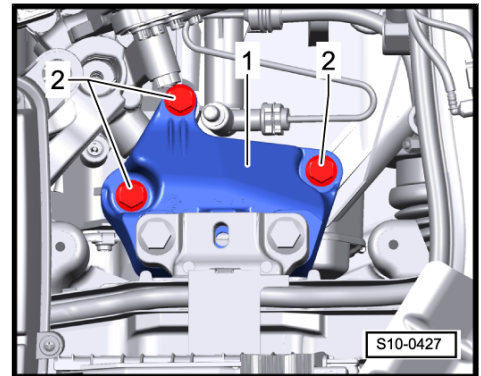

Protected by copyright. Copying for private or commercial purposes, in part or in whole, is not permitted unless authorised by ŠKODA AUTO A. S. ŠKODA AUTO A. S. does not guarantee or accept any liability with respect to the correctness of information in this document. Copyright by ŠKODA AUTO A. S. ©



- Move the engine/gearbox assembly with an assembly lever between the supporting arm of the engine mount -1- and the engine support -2- until the following dimensions are set:
- Between engine bracket and engine support there must be a distance -a- of 10 mm.
- The cast iron edge on the engine support -2- must be parallel to the supporting arm of the engine mount -1-; the dimension -x- must be the same at the front and rear.



### Note

The distance -a- = 10 mm can be checked e.g. with suitable round bars.

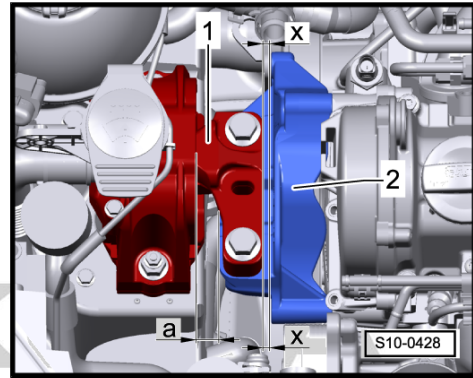

- Tighten the screws for the engine side assembly bracket  
⇒ [page 19](#) .
- Make sure that on the gearbox side the edges of the supporting arm of the gearbox mount -2- and the gearbox support -1- are parallel.
- The dimension -x- must be the same on both mount sides.
- Tighten the screws for the gearbox side assembly bracket  
⇒ [page 19](#) .

Further installation occurs in reverse order.

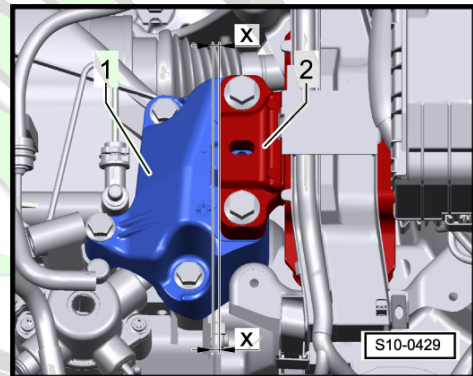

Protected by copyright. Copying for private or commercial purposes, in part or in whole, is not permitted unless authorised by ŠKODA AUTO A. S. ŠKODA AUTO A. S. does not guarantee or accept any liability with respect to the correctness of information in this document. Copyright by ŠKODA AUTO A. S.

## 13 – Crankshaft group

### 1 V-ribbed belt drive

#### 1.1 V-ribbed belt - Summary of components

##### 1.1.1 Summary of components - Vehicles without air conditioning

###### 1 - V-ribbed belt

- Routing of the ribbed V-belt ⇒ [page 24](#)
- mark the direction of rotation with chalk or a felt-tip pen before removing
- check for wear
- do not kink
- removing and installing ⇒ [page 26](#)

###### 2 - Fixing screw

- for crankshaft - belt pulley
- replace
- The clamping surface of the fixing screw must be free of grease and oil.
- insert oiled (thread)
- tighten ⇒ [page 41](#)

###### 3 - Crankshaft-belt pulley

- Contact surfaces must be free of oil and grease.

###### 4 - Diamond coated washer

- replace

###### 5 - 20 Nm

- When loosening and tightening, counterhold with the wrench for the water pump and power-assisted steering -MP 1-308 (V.A.G 1590)- to this end rework wrench for the water pump and power-assisted steering -MP 1-308 (V.A.G 1590)- ⇒ [page 103](#)

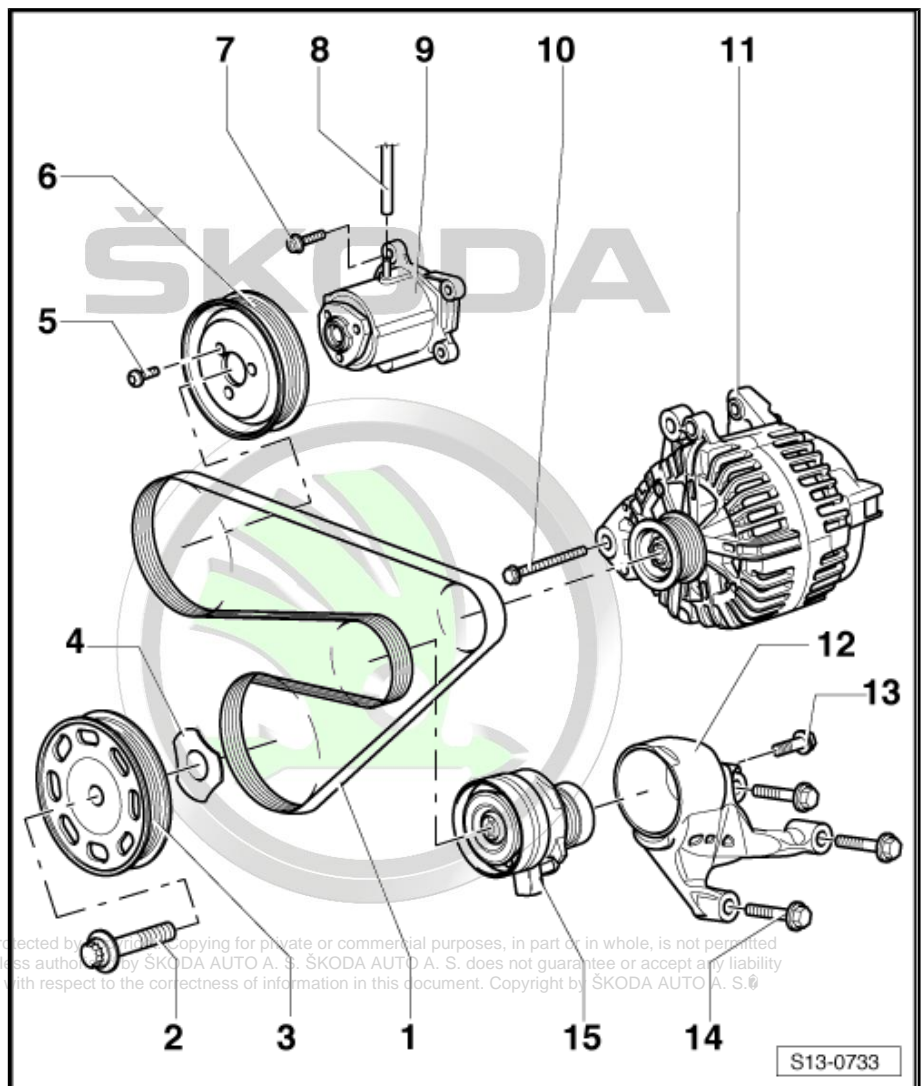

###### 6 - Belt pulley for coolant pump

- removing and installing ⇒ [page 41](#)

###### 7 - 9 Nm

###### 8 - Vacuum hose

- to solenoid valve for coolant circuit -N492- at intake manifold

###### 9 - Coolant pump

- removing and installing ⇒ [page 104](#)



## 10 - 25 Nm

### 11 - AC generator

- removing and installing ⇒ Electrical System ⇒ Rep. gr. 27
- to facilitate the positioning of the AC generator drive the threaded bushings on the generator slightly backwards

### 12 - Bracket for auxiliary units

- for tensioning device and AC compressor
- removing and installing ⇒ [page 29](#)

### 13 - 40 Nm + torque a further 90° (1/4 turn)

- replace

## 14 - 25 Nm

### 15 - Tensioning device for V-ribbed belt

- swivel tensioning device for V-ribbed belt with wrench to slacken the V-ribbed belt
- Secure the tensioning device with a 4 mm hexagon wrench or a locating pin -T10060 A-
- to remove, release screw Pos. 12

### Routing of the V-ribbed belt

- 1 - Belt pulley for coolant pump
- 2 - Tensioning pulley
- 3 - Belt pulley for AC generator
- 6 - Belt pulley for crankshaft

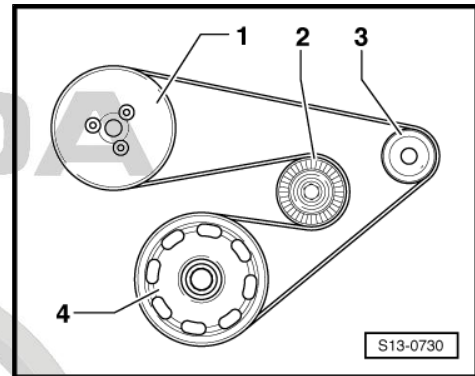

## 1.1.2 Summary of components - Vehicles with air conditioning

### 1 - V-ribbed belt

- Routing of the ribbed V-belt ⇒ [page 26](#)
- mark the direction of rotation with chalk or a felt-tip pen before removing
- check for wear
- do not kink
- removing and installing ⇒ [page 26](#)

### 2 - Fixing screw

- for crankshaft - belt pulley
- replace
- The clamping surface of the fixing screw must be free of grease and oil.
- insert oiled (thread)
- tighten ⇒ [page 41](#)

### 3 - Crankshaft-belt pulley

- Contact surfaces must be free of oil and grease.

### 4 - Diamond coated washer

- replace

### 5 - 20 Nm

- When loosening and tightening, counterhold with the wrench for the water pump and power-assisted steering -MP 1-308 (V.A.G 1590)- to this end rework wrench for the water pump and power-assisted steering - MP 1-308 (V.A.G 1590)- ⇒ [page 103](#)

### 6 - Belt pulley for coolant pump

- removing and installing ⇒ [page 41](#)

### 7 - 9 Nm

### 8 - Vacuum hose

- to solenoid valve for coolant circuit -N492- at intake manifold

### 9 - Coolant pump

- removing and installing ⇒ [page 104](#)

### 10 - 25 Nm

### 11 - Guide pulley, 40 Nm

### 12 - AC generator

- removing and installing ⇒ Electrical System ⇒ Rep. gr. 27
- to facilitate the positioning of the AC generator drive the threaded bushings on the generator slightly backwards

### 13 - 40 Nm + torque a further 90° (1/4 turn)

- replace

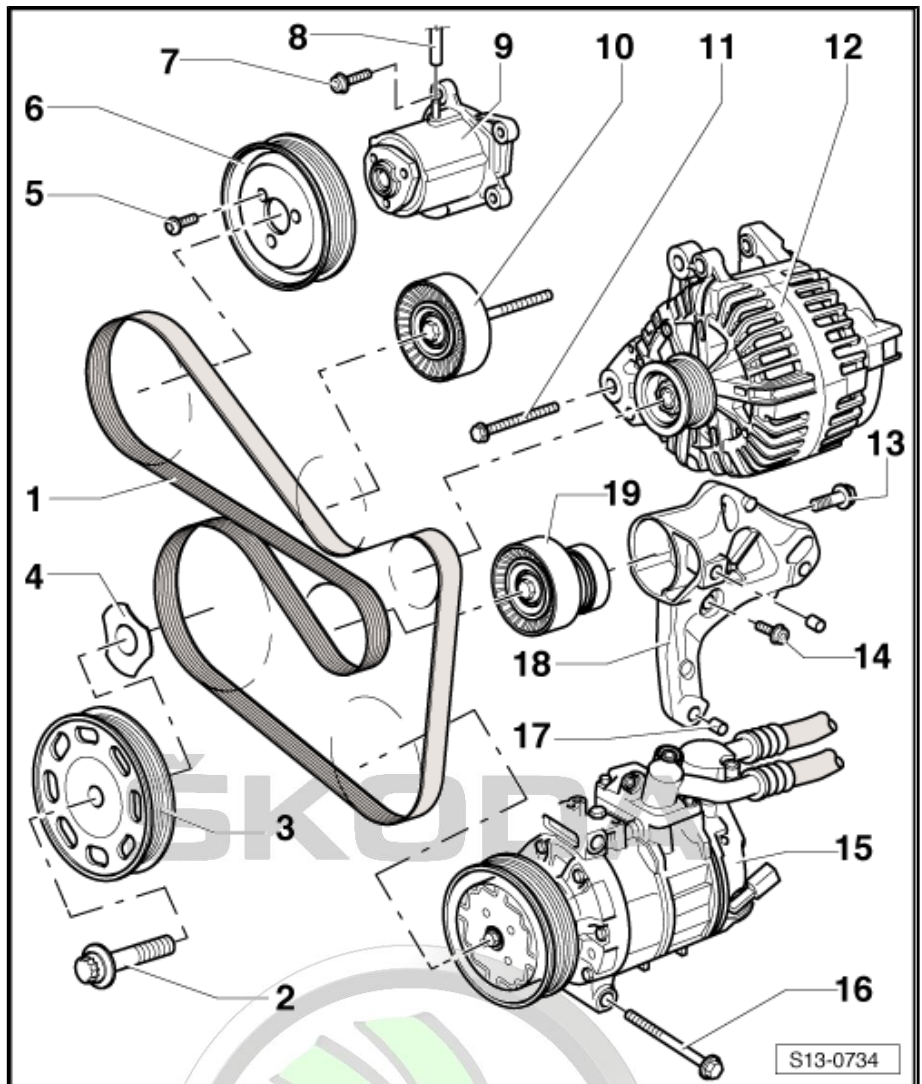

Protected by copyright. Copying for private or commercial purposes, in part or in whole, is not permitted unless authorised by ŠKODA AUTO A. S. ŠKODA AUTO A. S. does not guarantee or accept any liability with respect to the correctness of information in this document. Copyright by ŠKODA AUTO A. S. ©



14 - 25 Nm

15 - AC compressor

- removing and installing ⇒ Heating, Air Conditioning ⇒ Rep. gr. 87

16 - 25 Nm

17 - Fitting sleeve

18 - Bracket for auxiliary units

- for tensioning device and AC compressor
- removing and installing ⇒ [page 29](#)

19 - Tensioning device for V-ribbed belt

- swivel tensioning device for V-ribbed belt with wrench to slacken the V-ribbed belt
- Secure the tensioning device with a 4 mm hexagon wrench or a locating pin -T10060 A-
- to remove, release screw Pos. 12

### Routing of the V-ribbed belt

- 1 - Belt pulley for coolant pump
- 2 - Guide pulley
- 3 - Belt pulley for AC generator
- 4 - Tensioning pulley
- 5 - Belt pulley for AC compressor
- 6 - Belt pulley for crankshaft

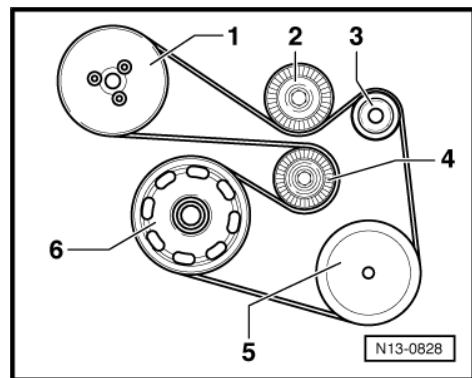

## 1.2 Removing and installing V-ribbed belt

### Special tools and workshop equipment required

- ◆ Locking pin -T10060 A-

### Removing

- Remove noise insulation ⇒ Body Work ⇒ Rep. gr. 50 .



#### Caution

***Risk of damage through reversing the rotation direction of an already used V-ribbed belt.***

- ◆ ***Mark the direction of rotation with chalk or a felt-tip pen for the re-installation before removing the V-ribbed belt.***

### For vehicles with air conditioning

- Loosen the V-ribbed belt by swivelling the tensioning device using the ring spanner SW 16 -in direction of arrow-.
- Interlock the tensioning element with the locking pin -T10060 A- .

### For vehicles without air conditioning

- Swivel the tensioning device with the locating pin -T10060 A- and lock, the V-ribbed belt is therefore slackened.

### Continued for all vehicles

- Remove the V-ribbed belt.

### Install



#### Note

- ◆ *Before fitting the V-ribbed belt make sure that all assemblies (AC generator, AC compressor, coolant pump) are securely mounted.*
- ◆ *Pay attention to the correct position and rotation direction of the V-ribbed belt in the belt pulley when installing it.*
- First of all place the ribbed V-belt onto the crankshaft - belt pulley. Then shift the belt onto the tensioning roller.

Further installation occurs in a similar way in reverse order to removal.

- Start engine and check ribbed V-belt run.

## 1.3 Removing and installing bracket for top auxiliary units

Without warranty copyright. Copying for private or commercial purposes, in part or in whole, is not permitted unless authorised by ŠKODA AUTO A. S. ŠKODA AUTO A. S. does not guarantee or accept any liability with respect to the correctness of information in this document. Copyright by ŠKODA AUTO A. S. ©

### Removing

#### Special tools and workshop equipment required

- ◆ Catch pan , e.g. -VAS 6208-
- ◆ Hose binding claw

### Removing

- Remove V-ribbed belt ⇒ [page 26](#) .
- Remove alternator ⇒ Electrical System ⇒ Rep. gr. 27 .
- Drain the coolant from the engine cooling system ⇒ [page 99](#) .
- Remove lambda probe -G39- -1-.

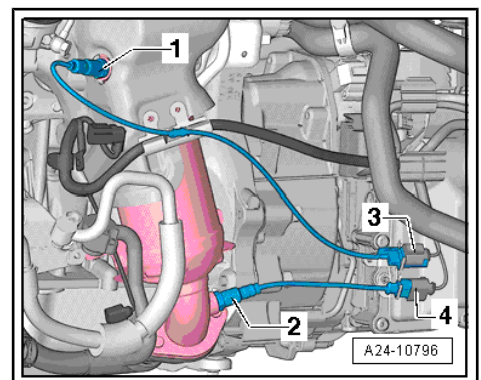
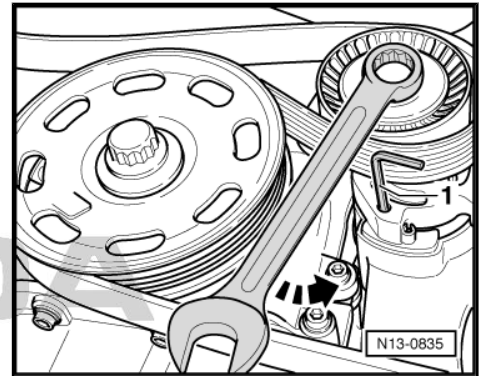



- Release screws -arrows- and remove heat shield -1-.

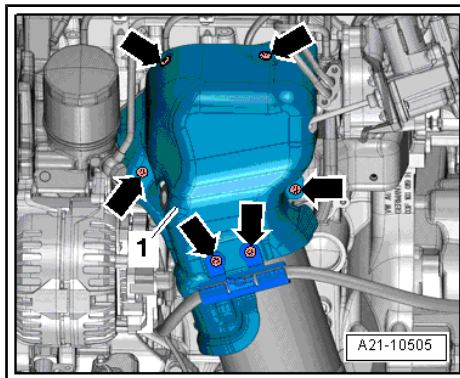

- Open the spring strap clamp -1- with the hose binding claw and detach the coolant hose.



**Note**

*When removing the oil feed line, make sure that the oil does not penetrate into the generator! Therefore, cover the generator with a clean cloth!*

- Unscrew hollow screw -2- and fixing screw -3- and remove the oil feed line.
- Unscrew fixing screws -1- and remove bracket.

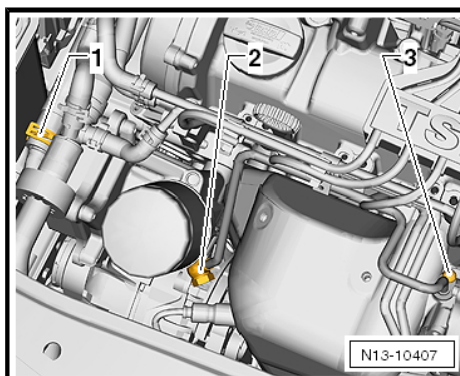

**Install**

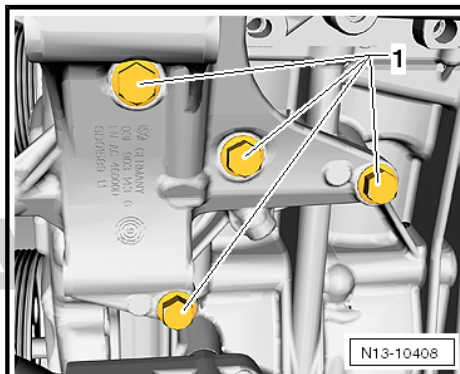

- Fit the bracket for auxiliary units to the cylinder block.
- Tighten fixing screws -1- to 25 Nm.
- Install oil feed line.

**Tightening torques:**

Component	Nm
Fixing screw to exhaust turbocharger	8 Nm
Hollow screw (replace gasket rings)	20 Nm

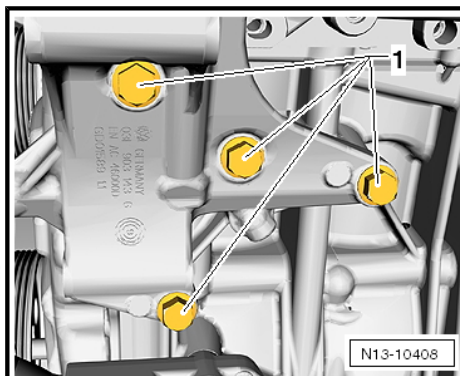



- Connect the coolant hose -1- and attach it to the engine oil cooler and remove the hose clamp -MP7-602 (3094)- .
- Top up and bleed cooling system ⇒ [page 99](#) .
- Inspect coolant level in the coolant expansion reservoir, top up with coolant if necessary.
- Install alternator ⇒ Electrical System ⇒ Rep. gr. 27 .
- Install the V-ribbed belt ⇒ [page 26](#) .

Further installation occurs in a similar way in reverse order to removal.

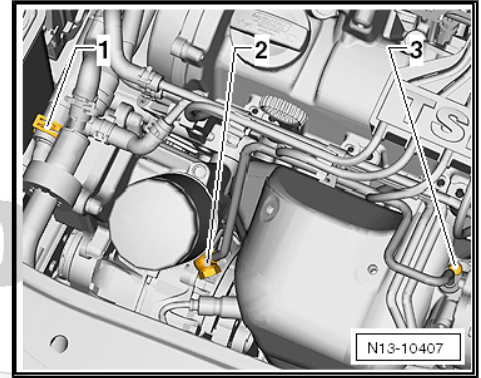

## 1.4 Removing and installing bracket for bottom auxiliary units

### Removing

- Remove V-ribbed belt ⇒ [page 26](#) .
- Remove alternator ⇒ Electrical System ⇒ Rep. gr. 27 .



#### WARNING

*Risk of injury through refrigerant.*

- ◆ *Do not open the refrigerant circuit of the air conditioning system.*



#### Caution

*Risk of damaging refrigerant lines and hoses.*

- ◆ *Do not over-tension or buckle refrigerant lines and hoses.*

Protected by copyright. Copying for private or commercial purposes, in part or in whole, is not permitted unless authorised by ŠKODA AUTO A. S. ŠKODA AUTO A. S. does not guarantee or accept any liability with respect to the correctness of information in this document. Copyright by ŠKODA AUTO A. S.

- Remove AC compressor from the bracket ⇒ [page 23](#) .
- Mount the AC compressor in such a way that the refrigerant lines/hoses are not under tension.
- Unscrew fixing screws -1- and remove holder with tensioning element.

### Install

- Fit the bracket for auxiliary units to the cylinder block.

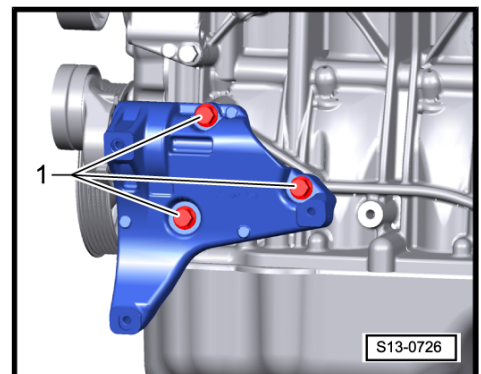



- Tighten fixing screws -1- to 25 Nm.

Tightening torque of tensioning device: ⇒ [page 23](#)

The further assembly is carried out in reverse order to disassembly.

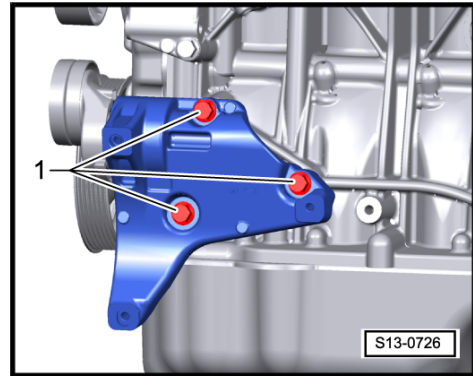

# ŠKODA



Protected by copyright. Copying for private or commercial purposes, in part or in whole, is not permitted unless authorised by ŠKODA AUTO A. S. ŠKODA AUTO A. S. does not guarantee or accept any liability with respect to the correctness of information in this document. Copyright by ŠKODA AUTO A. S. ©



## 2 Camshaft drive

### 2.1 Camshaft drive - Summary of components



#### Note

- ◆ Before assembly oil all bearing and contact surfaces.
- ◆ If considerable quantities of metal swarf or abrasion is found when carrying out engine repairs, this can be subject to damage to the crankshaft and conrod bearings. In order to avoid consequential damage, after the repair perform the following tasks:
  - Carefully clean the oil galleries.
  - Replace oil spray jets.
  - Replace engine oil cooler.
  - Replace oil filter.

#### 1 - Cylinder head with cylinder head cover

- Removing and installing cylinder head  
 ⇒ [page 81](#)
- Removing and installing cylinder head cover  
 ⇒ [page 73](#)
- The sealing surfaces must not be reworked

#### 2 - Cylinder block

- Disassembling and assembling pistons and conrods ⇒ [page 52](#)

#### 3 - Bracket for bottom auxiliary units

- for tensioning device and AC compressor
- removing and installing  
 ⇒ [page 29](#)

#### 4 - 25 Nm

#### 5 - Oil pan

- removing and installing  
 ⇒ [page 93](#)
- fit with silicone sealant D 176 600 A1

#### 6 - 13 Nm

#### 7 - 150 Nm + torque a further 180° (1/2 turn)

- replace
- The clamping surface of the fixing screw must be free of grease and oil.

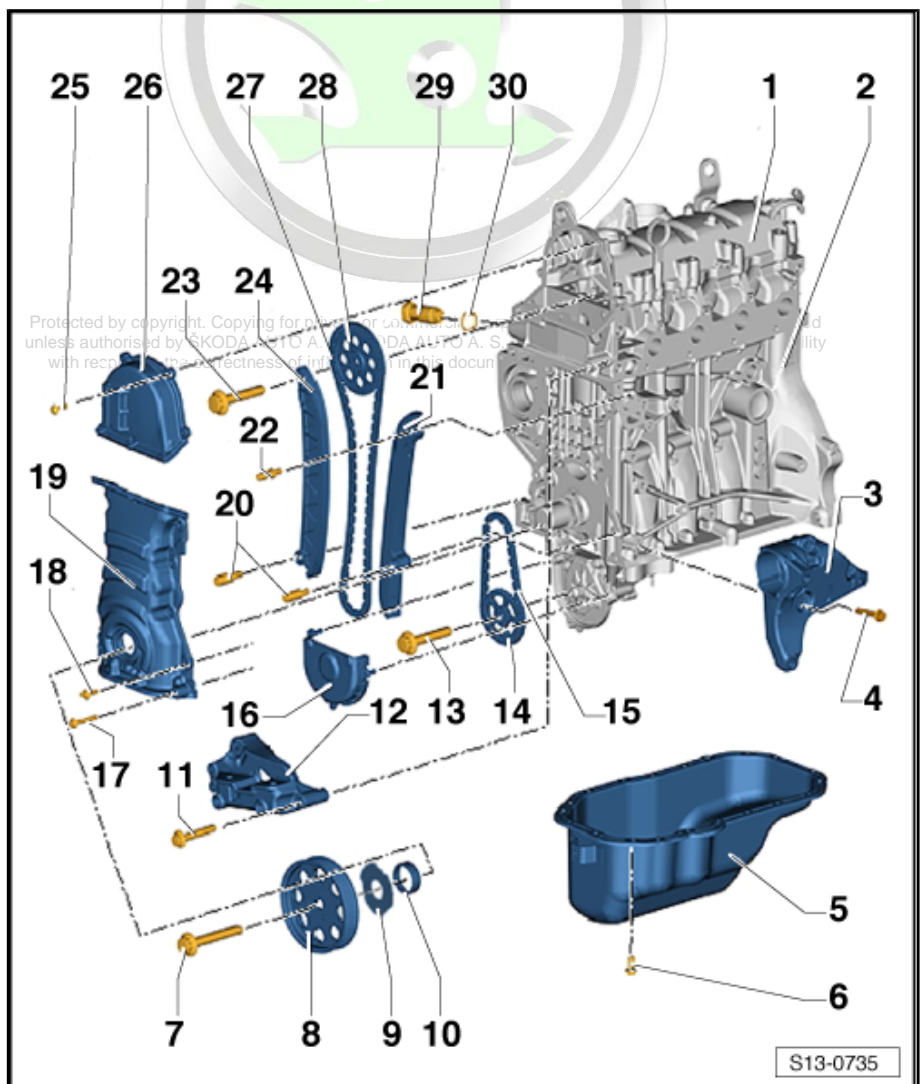

S13-0735



- insert oiled (thread)
- Secure belt pulley with counterholder -3415- to prevent it from turning

#### 8 - Belt pulley

- Pay attention to tightening process ⇒ [page 41](#)
- Contact surfaces must be free of oil and grease.
- Counterhold belt pulley with counterholder -T30004 (3415)- with bolt -T30004/2 (3415/2)- to prevent it from turning

#### 9 - Diamond coated washer

- replace

#### 10 - Sealing ring

- replace
- removing and installing ⇒ [page 40](#)

#### 11 - 50 Nm

#### 12 - Engine support bracket

#### 13 - 20 Nm + torque a further 90° (1/4 turn)

- replace

#### 14 - Sprocket

- for oil pump drive
- Contact surfaces must be free of oil and grease.
- Counterhold sprocket with counterholder -T10172-

#### 15 - Drive chain for oil pump

- mark running direction (installed position) before removing

#### 16 - Bottom cover

#### 17 - 5 Nm + torque a further 30°

- Screw: M6x40

#### 18 - 5 Nm + torque a further 30°

- Screw: M6x20

#### 19 - Bottom timing case

- removing and installing ⇒ [page 35](#)

#### 20 - Bearing bolt, 18 Nm

#### 21 - Sliding rail

- for timing chain

#### 22 - Bearing bolt, 18 Nm

#### 23 - 50 Nm + torque a further 90° (1/4 turn)

- replace

#### 24 - Tensioning rail

- for timing chain

#### 25 - 8 Nm

#### 26 - Top timing case

- removing and installing ⇒ [page 33](#)

# ŠKODA

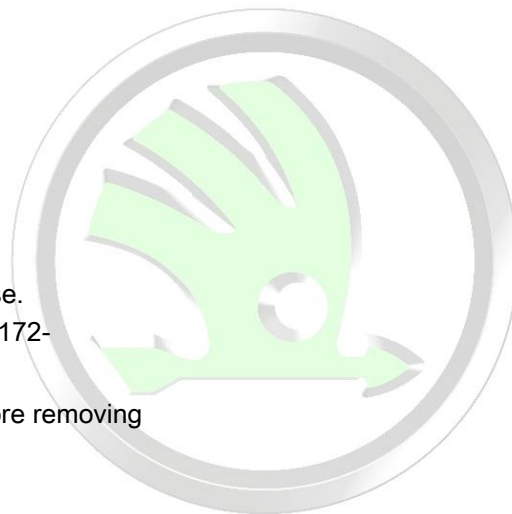

Protected by copyright. Copying for private or commercial purposes, in part or in whole, is not permitted unless authorised by ŠKODA AUTO A. S. ŠKODA AUTO A. S. does not guarantee or accept any liability with respect to the correctness of information in this document. Copyright by ŠKODA AUTO A. S. ©

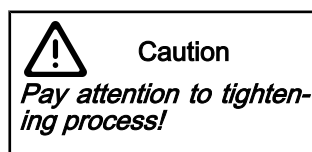

## 27 - Timing chain

- ❑ removing and installing ⇒ [page 66](#)

## 28 - Sprocket

- ❑ Counterhold sprocket with counterholder -T10172-

## 29 - Chain tensioner - 60 Nm

- ❑ for timing chain

## 30 - Sealing ring

- ❑ replace

## 2.2 Removing and installing the top timing case

### Special tools and workshop equipment required

- ◆ Hose binding claw
- ◆ Sealant -D 176 501 A1-
- ◆ Screw M6x70 (2x) : adapt the screws by sawing off the heads
- ◆ Sealant remover gasket stripper (bearing code GST, bearing article no. R 34402), manufacturer Retech s.r.o.
- ◆ Cleaning and degreasing agent , e.g. -D 000 401 04-
- ◆ Protective goggles and gloves

### Removing

- Drain coolant ⇒ [page 99](#) .
- Slacken clamps -1- and -2- and detach coolant hoses.
- Unlatch the clamp -3- and pull it towards the top with the coolant hoses.
- Place the coolant hoses to the rear.

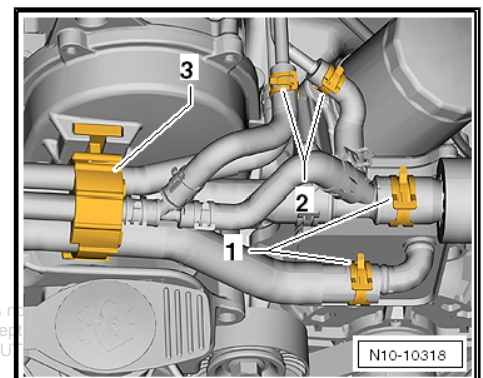

Protected by copyright. Copying for private or commercial purposes, in part or in whole, is prohibited unless authorised by ŠKODA AUTO A. S. ŠKODA AUTO A. S. does not guarantee or accept responsibility with respect to the correctness of information in this document. Copyright by ŠKODA AUTO A. S.

- Unscrew all the fixing screws from the top timing case -1-.
- Remove timing case.

### Install

Installation is performed in the reverse order, pay attention to the following points:

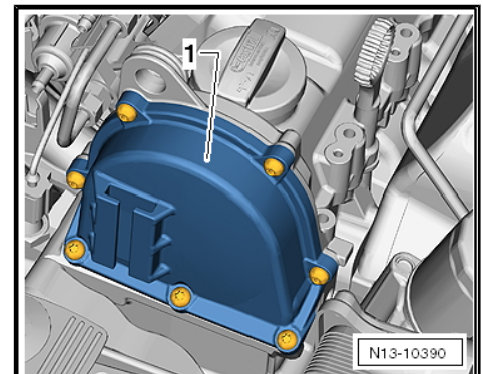



- To better guide the timing case, screw two pin screws M6x70 -1- into the cylinder head cover.



**WARNING**

*Wear protective gloves when working with sealant and grease remover!*

- Remove residual sealant from the sealing surfaces on the top timing case and at the cylinder head with chemical sealant remover.
- Degrease the sealing surfaces.
- Cut off nozzle tube at the front marking (Ø of nozzle approx. 3 mm).



**Note**

- ◆ *The installation procedure must not last longer than 6 minutes from the moment the sealant is applied until the moment the fixing screws are tightened to 8 Nm.*
  - ◆ *The sealant begins to harden after 6 minutes.*
  - ◆ *Ensure that the tightening process of the fixing screws is carried out in two steps.*
- Apply sealant - D 176 501 A1- on the sealing surface -1-.
  - Apply a little more sealant in the area of the -arrows-.

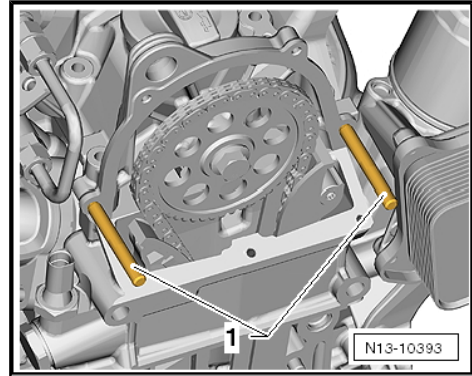

ŠKODA

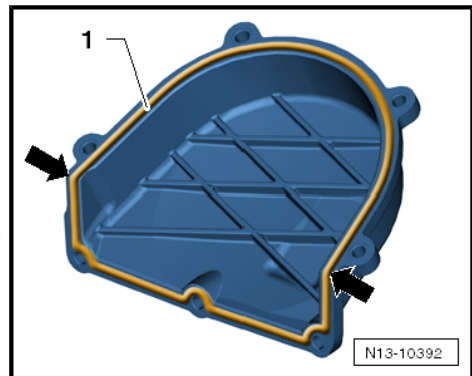

- Position the timing case -1- onto the pin screws -2-.
- Slide the timing case -1- up to the stop onto the cylinder head cover.
- Make sure that the timing case does not tilt.
- Release the stud bolts and screw in the fixing screws by hand.
- Stage I of the tightening process.**

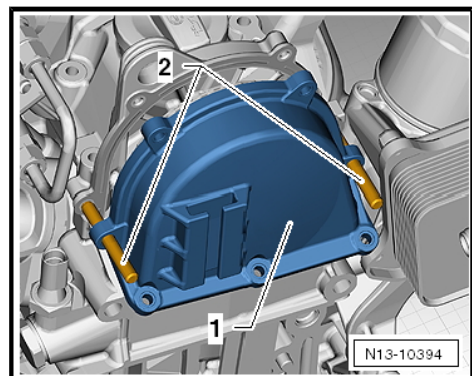

- Tighten the fixing screws to 5 Nm in the specified order -A- to -E-.

**Stage II of the tightening process.**

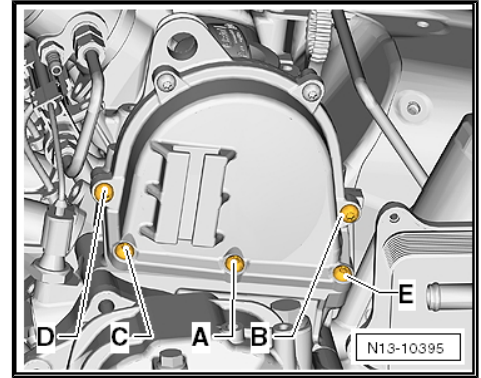

- Tighten the fixing screws to 8 Nm in the specified order -A- to -G-.

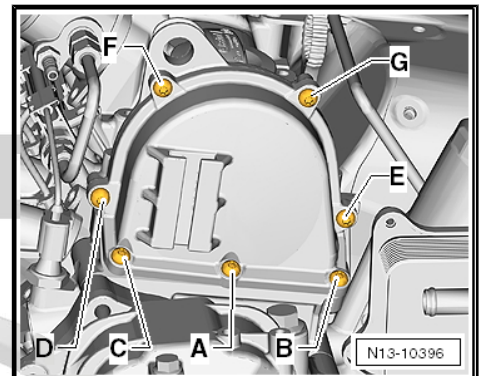

- Push the clamp -3- from above fully into the bracket.
- Fit on the coolant hoses and attach the spring strap clamps -1- and -2-.
- Top up coolant ⇒ [page 99](#) .

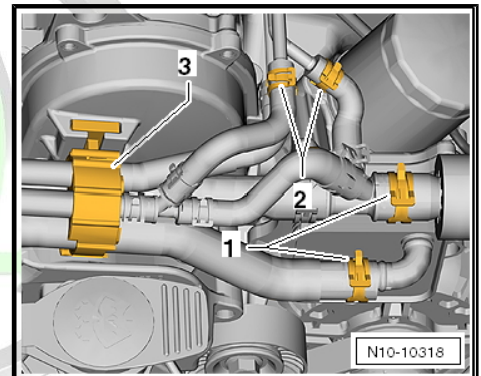

## 2.3 Removing and installing the bottom timing case

Protected by copyright. Copying for private or commercial purposes, in part or in whole, is not permitted unless authorised by ŠKODA AUTO A. S. ŠKODA AUTO A. S. does not guarantee or accept any liability with respect to the correctness of information in this document. Copyright by ŠKODA AUTO A. S. ©

### Special tools and workshop equipment required

- ◆ Assembly device -T10417/1-
- ◆ Counterholder -T30004 (3415)-
- ◆ Bolt -T30004/2 (3415/2)-
- ◆ Sealant remover gasket stripper (bearing code GST, bearing article no. R 34402), manufacturer Retech s.r.o.
- ◆ Cleaning and degreasing agent , e.g. -D 000 401 04-
- ◆ Protective goggles and gloves
- ◆ Sealant - D 176 600 A1-

### Removing

- Remove noise insulation ⇒ Body Work ⇒ Rep. gr. 50 .
- Remove the front right wheelhouse liner ⇒ Body Work ⇒ Rep. gr. 66 .



- Remove V-ribbed belt ⇒ [page 26](#) .
- Remove dust cap -1-.
- Remove guide pulley -2-.
- Remove belt pulley for coolant pump, to do so counterhold the belt pulley with the water pump wrench -V.A.G 1590- .
- Remove crankshaft-belt pulley ⇒ [page 41](#) .
- Removing the oil pan ⇒ [page 93](#) .

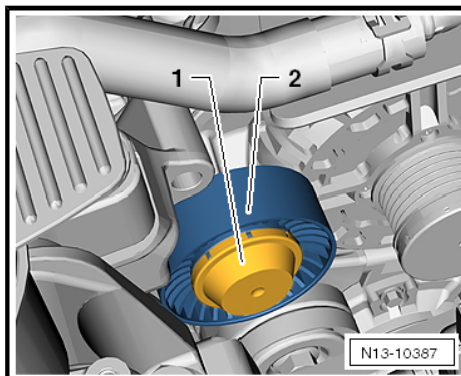

- Unscrew all the fixing screws from the timing case -1-.
- Carefully remove timing case.

**Install**

Installation is performed in the reverse order, pay attention to the following points:



**WARNING**

*Wear protective gloves when working with sealant and grease remover!*

- Remove residual sealant from the sealing surfaces on the bottom timing case and at the cylinder block with chemical sealant remover.
- Degrease the sealing surfaces.
- Cut off nozzle tube at the front marking (Ø of nozzle approx. 3 mm).

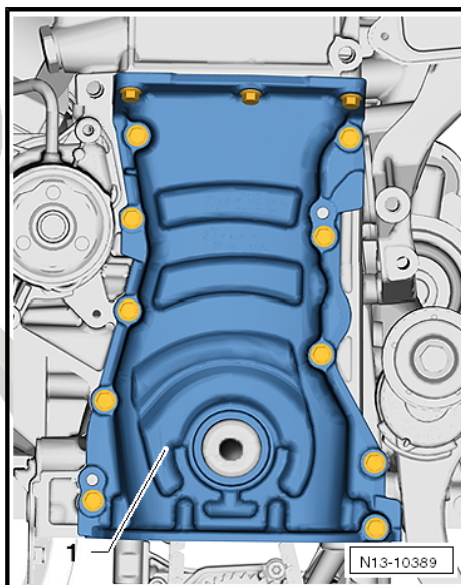

**Note**

- ◆ *The installation procedure must not last longer than 6 minutes from the moment the sealant is applied until the moment the fixing screws are tightened to 5 Nm + torqued a further 30°.*
- ◆ *The sealant begins to harden after 6 minutes.*
- ◆ *Insert new fixing screws.*

- Apply sealant D 176 600 A1 on the sealing surface -1-.
- The sealant bead must be 2...3 mm thick and must run past the area of the bolt holes all around the holes.

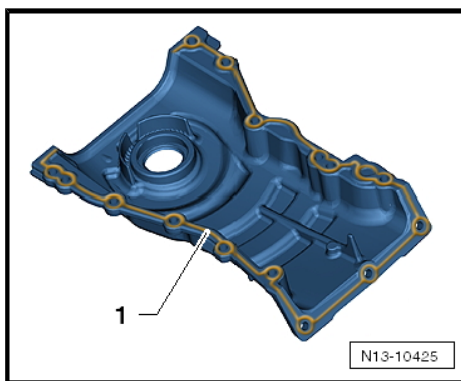



- Fit the assembly device -T10417/1- on the crankshaft journal.
- Carefully slide the bottom timing case -1- together with the gasket ring over the assembly device.
- Remove the assembly device from the crankshaft journal.

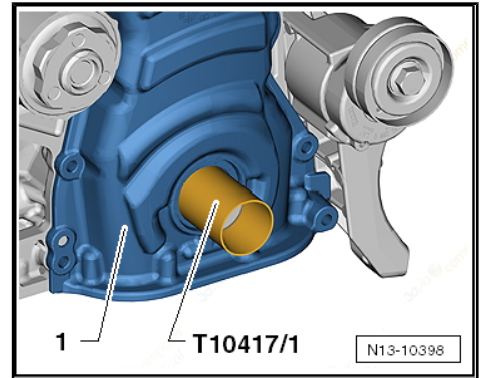

- Slide the bottom timing case onto the dowel pins -arrows- until it rests against the cylinder block.

Make sure that the timing case does not tilt.



**Caution**

*Pay attention to the tightening torque of the fixing screws!*

*When installing, use new screws.*

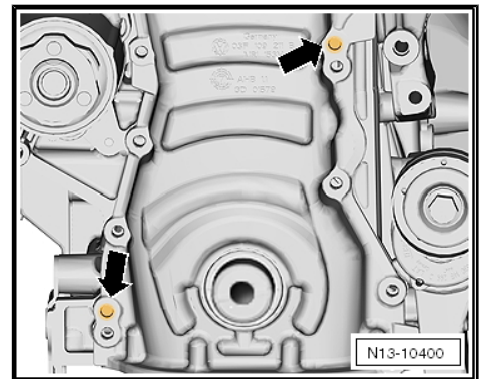

- First of all tighten the new fixing screws of the timing case evenly by hand.

- Tighten the fixing screws in the specified order -A- to -M-.

Tightening torque: 5 Nm + torque a further 30°

Install crankshaft belt pulley => [page 41](#) .

**Tightening torques**

Belt pulley for coolant pump: 20 Nm

Guide pulley: 40 Nm

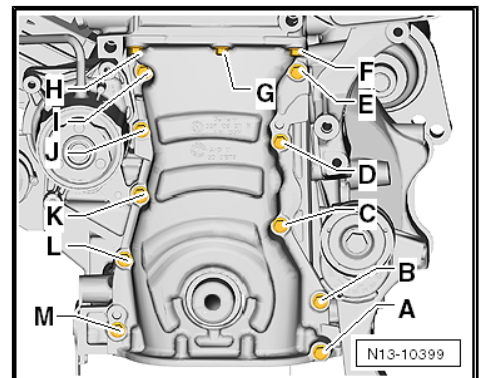

Protected by copyright. Copying for private or commercial purposes, in part or in whole, is not permitted unless authorised by ŠKODA AUTO A. S. ŠKODA AUTO A. S. does not guarantee or accept any liability with respect to the correctness of information in this document. Copyright by ŠKODA AUTO A. S. ©



## 3 Sealing flanges and flywheel

### 3.1 Summary of components

#### 1 - 150 Nm + torque a further 180° (1/2 turn)

- replace
- The clamping surface of the fixing screw must be free of grease and oil.
- insert oiled (thread)
- Counterhold belt pulley with counterholder - T30004 (3415)- with bolt -T30004/2 (3415/2)- to prevent it from turning

#### 2 - Belt pulley

- removing and installing ⇒ [page 41](#)
- Contact surfaces must be free of oil and grease.

#### 3 - Diamond coated washer

- replace

#### 4 - Sealing ring

- replace

#### 5 - Engine

#### 6 - 60 Nm + torque a further 90° (1/4 turn)

- replace

#### 7 - Flywheel

- on vehicles with automatic gearbox DSG - two-mass flywheel version
- removing and installing ⇒ [page 39](#)

#### 8 - Intermediate plate

- must be positioned on dowel sleeves
- do not damage/bend during assembly work

#### 9 - 10 Nm

- replace

#### 10 - Sealing flange on the gearbox side

- Only replace sealing flange complete with gasket ring and rotor
- replace ⇒ [page 44](#)

#### 11 - Engine speed sender -G28- , 5 Nm

- with captive screw
- removing and installing ⇒ [page 196](#)

#### 12 - 5 Nm

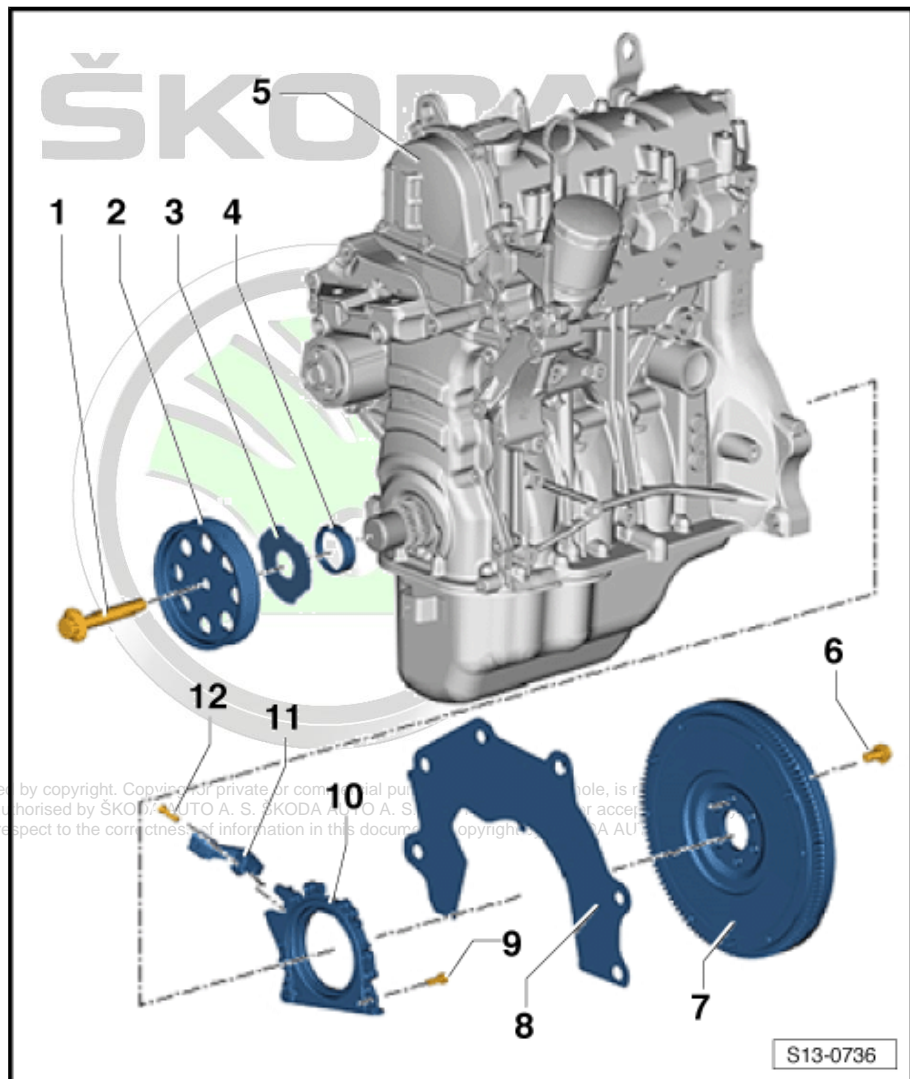



### 3.2 Removing and installing flywheel

#### Special tools and workshop equipment required

- ◆ Counterholder -MP1-223 (3067)-

or

- ◆ Engine mount -MP 1-202 (VW 540)-
- ◆ Bushing -T30010 (VW 540/1B)-
- ◆ Flywheel lock -MP 1-504-

#### Removing

- Gearbox is removed.
- Remove clutch on vehicles with manual gearbox ⇒ Gearbox; Rep. gr. 30 .

#### Engine installed

- Insert the counterholder -MP1-223 (3067)- into the bore hole on the cylinder block.

- Fitting position of the counterholder:

A - for tightening

B - for slackening

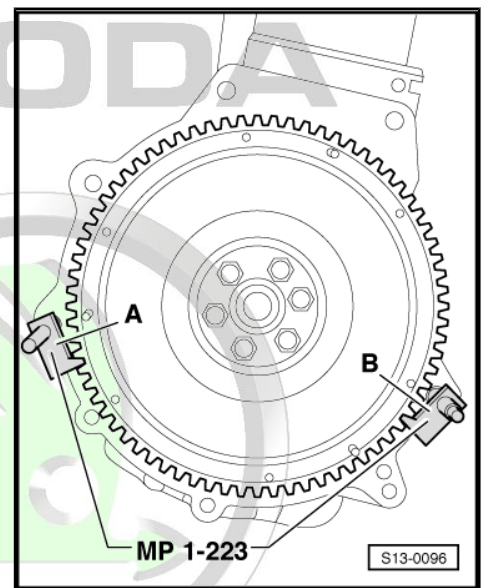

#### Engine removed

- Position the flywheel lock -MP 1-504- on the starter ring gear and turn crankshaft until it rests against the sleeve -T30010 - .

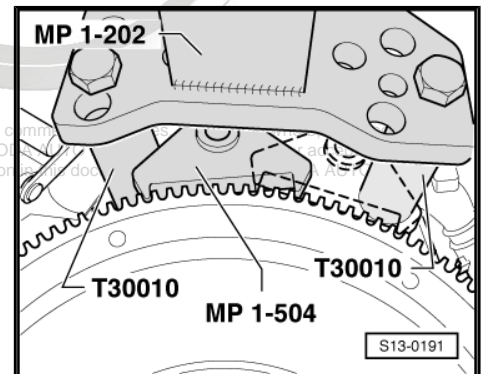

Protected by copyright. Copying for private or commercial use is prohibited unless authorised by ŠKODA AUTO A. S. ŠKODA is not responsible for any errors with respect to the correctness of information.



### Vehicles with two-mass flywheel

- Rotate the secondary side -A- of the two-mass flywheel in such a way that the screws -B- are positioned in the middle of the holes -arrows-.



#### Caution

*When unscrewing the screws -B-, ensure that no screw head catches on the secondary side -A- of the two-mass flywheel, otherwise the flywheel will be damaged.*

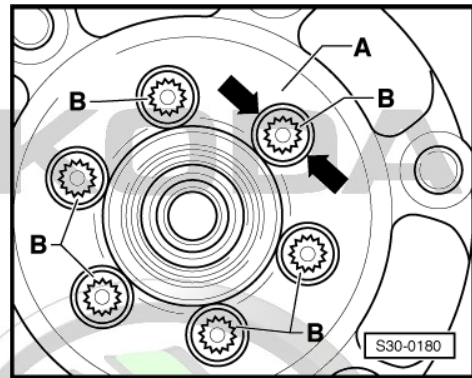

#### Continued for all

- Release screws and remove flywheel.

#### Install

Installation is performed in the reverse order, pay attention to the following points:



#### Note

*Use new screws for attaching.*

### Vehicles with two-mass flywheel

- Rotate the secondary side -A- of the two-mass flywheel in such a way that the screws -B- are positioned in the middle of the holes -arrows-.

#### Continued for all

1. Screw in all the screws by hand.
2. Tighten all the screws crosswise to 60 Nm.
3. Torque all the screws crosswise a further 90° (1/4 turn).

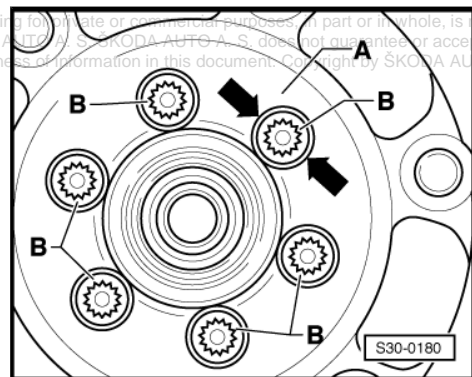

## 3.3 Replacing crankshaft seal on belt pulley side

#### Special tools and workshop equipment required

- ◆ Gasket ring extractor -T30015 (3240)-
- ◆ Assembly device -T10417-
- ◆ Adapter piece -T30003 (3161)-

#### Removing

- Remove V-ribbed belt ⇒ [page 26](#) .
- Rotate the crankshaft in direction of rotation of engine on TDC for cylinder 1 ⇒ [page 58](#) .
- Remove crankshaft-belt pulley ⇒ [page 41](#) .



- Push the adapter piece -3161- into the gasket ring extractor -3240- .
- Unscrew the inner part of the gasket ring extractor -3240- up to the beginning of the thread and lock with the knurled screw.

ŠKODA

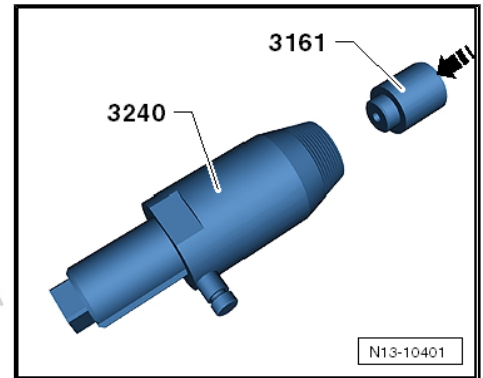

- Oil the thread head of the gasket ring extractor, position and apply pressure when screwing it into the gasket ring as far as possible.
- Slacken knurled screw and turn inner side in -direction of arrow- against the crankshaft until the gasket ring is pulled out.

**Install**

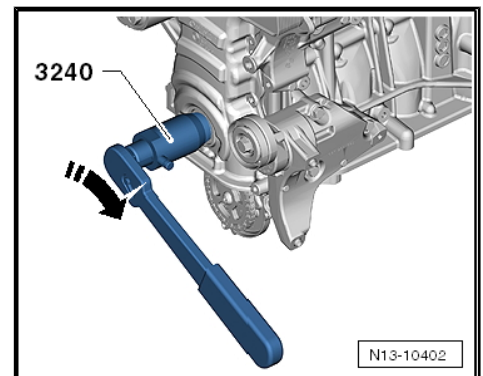
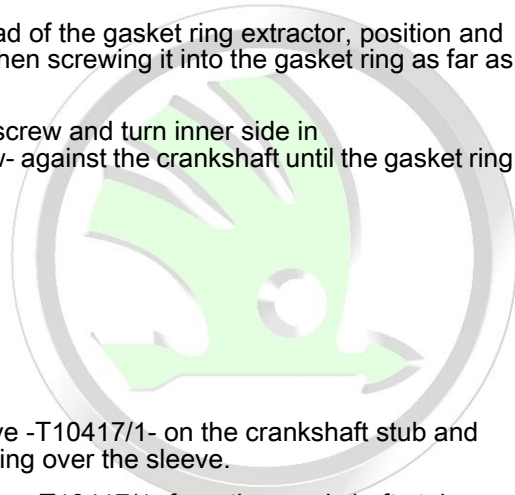

- Position the sleeve -T10417/1- on the crankshaft stub and push the gasket ring over the sleeve.
- Remove the sleeve -T10417/1- from the crankshaft stub.

Protected by copyright. Copying for private or commercial purposes, in part or in whole, is not permitted unless authorised by ŠKODA AUTO A. S. ŠKODA AUTO A. S. does not guarantee or accept any liability with respect to the correctness of information in this document. Copyright by ŠKODA AUTO A. S.

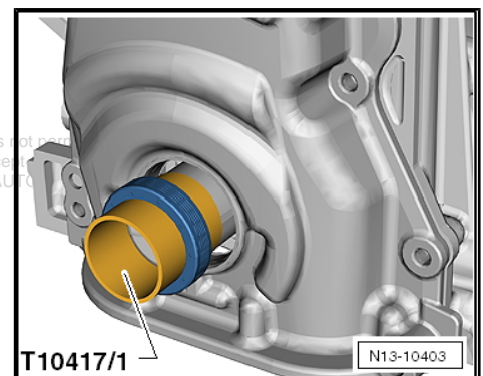

- Press the gasket ring with the assembly device -T10417- by striking uniformly up to the stop in the timing case.

Install crankshaft belt pulley => [page 41](#) .

Further installation occurs in a similar way in reverse order to removal.

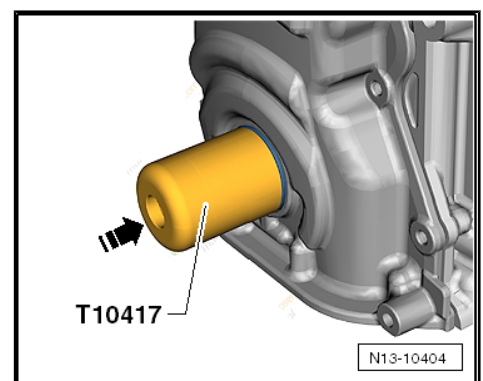

### 3.4 Removing and installing crankshaft-belt pulley

**Special tools and workshop equipment required**

- ◆ Counterholder -T30004 (3415)-
- ◆ Bolt -T30004/2 (3415/2)-
- ◆ Locating screw -T10340-



### Note

- ◆ *In order to avoid that the tightening torque of the fixing screw for the crankshaft-belt pulley is inaccurate due to slip, the fixing screw -T10340- must be used in addition to the counterholder -T30004- .*
- ◆ *The crankshaft is only locked in direction of rotation of engine using the fixing screw -T10340- .*



### Caution

#### Risk of engine damage!

- ◆ *The fixing screw -T10340- must not be used to slacken the fixing screw for the crankshaft-belt pulley - only for tightening!*
- ◆ *The locating screw -T10340- must only be screwed in the „TDC“ position of the crankshaft.*

### Removing

- Remove V-ribbed belt ⇒ [page 26](#) .
- Rotate the crankshaft in direction of rotation of engine on TDC for cylinder 1 ⇒ [page 58](#) .
- Counterhold belt pulley with counterholder -T30004 (3415)- with bolt -T30004/2 (3415/2)- and release fixing screw for belt pulley.

### Install

#### Vehicles with auxiliary heating.

- Screw out the screws -1 and 2- of the brackets for the coolant pipes for the auxiliary heating -3-.

#### Continued for all vehicles

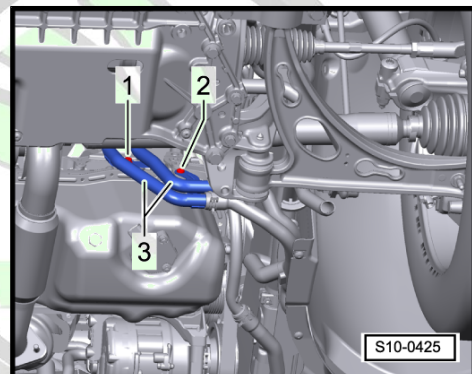
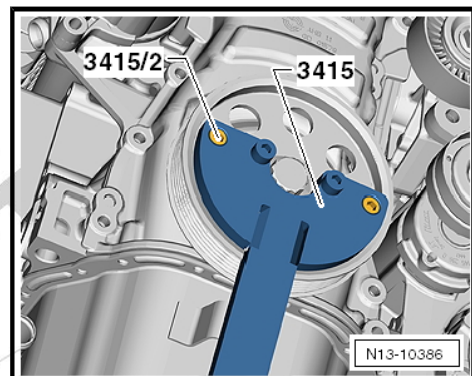

- Release fixing screws -1- and remove bracket for coolant pipe -2-.

**i** Note

- ◆ *Make sure that all clamping surfaces of the fixing screw are free of oil and grease up to the crankshaft chain sprocket.*
- ◆ *Always use a new screw of the crankshaft belt pulley.*
- Install the belt pulley and tighten the new fixing screw by hand.

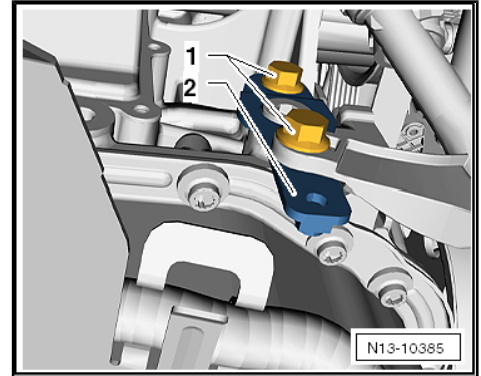

- Release screw plug -arrow- at cylinder block.

**i** Note

*Using the fixing screw should prevent the crankshaft from turning when tightening to the tightening torque.*

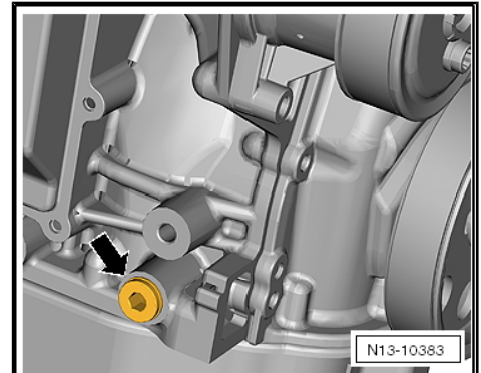

- Turn the fixing screw -T10340- up to the stop in the cylinder block.

**!** Caution

*If the fixing screw -T10340 - cannot be screwed in up to the stop, the crankshaft is not in the correct position!  
In this case proceed as described below.*

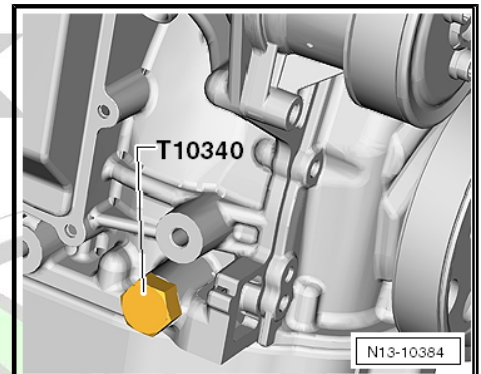

- Unscrew the fixing screw.
- Turn crankshaft 90° (1/4 turn) in direction of rotation of engine.
- Turn the fixing screw -T10340- up to the stop in the cylinder block.
- Tighten fixing screw -T10340- to 30 Nm.
- Turn crankshaft up to the stop in direction of rotation of engine.

The crankshaft is locked in direction of rotation of engine with the fixing screw -T10340- .

**!** Caution

*Absolutely use the counterholder -T30004 (3415)- with bolt -T30004/2 (3415/2)- when tightening the fixing screw of the belt pulley in order to avoid damage to the fixing screw.*

- Counterhold belt pulley with counterholder -T30004 (3415)- with bolt -T30004/2 (3415/2)- and tighten fixing screw for belt pulley.

**Tightening torque: 150 Nm + torque a further 1/2 turn (180°)**



- Release the fixing screw -T10340- from the cylinder block.

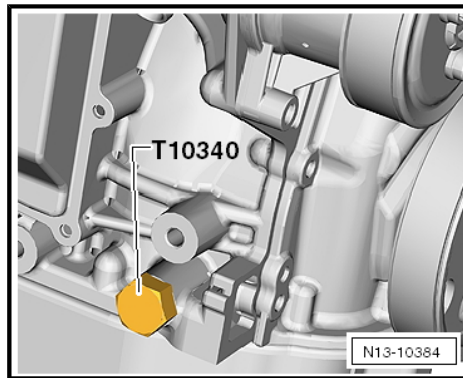

- Screw the screw plug again into the cylinder block. Tightening torque: 30 Nm.

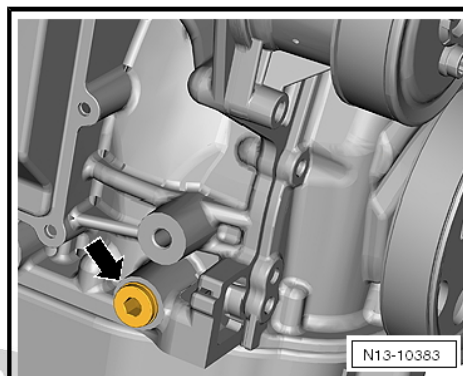

- Install bracket for coolant pipe -2- and tighten screws -1-.

#### Tightening torque

Screw M6 = 10 Nm

Screw M8 = 20 Nm

- Install the V-ribbed belt ⇒ [page 26](#) .

Further installation occurs in a similar way in reverse order to removal.

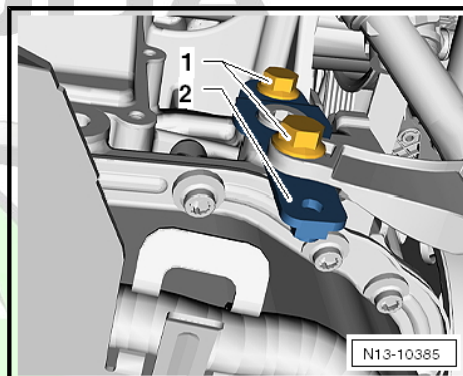

## 3.5 Replace sealing flange on the gearbox side

### Special tools and workshop equipment required

- ◆ Assembly tool -T10134-
- ◆ Feeler gauge
- ◆ Steel straightedge
- ◆ Screw M6x35 (3x)
- ◆ Screw M7x35 (2x)

Protected by copyright. Copying for private or commercial purposes, in part or in whole, is not permitted unless authorised by ŠKODA AUTO A. S. ŠKODA AUTO A. S. does not guarantee or accept any liability with respect to the correctness of information in this document. Copyright by ŠKODA AUTO A. S. ©

### 3.5.1 Removing

- Gearbox is removed.
- Remove the flywheel.
- Remove intermediate plate.
- Position engine on TDC for cylinder 1 ⇒ [page 58](#) (do not remove the cover for the camshafts).
- Removing the oil pan ⇒ [page 93](#) .



- Remove engine speed sender -G28- -arrow-.
- Unscrew the fixing screws of the sealing flange.

**i** Note

*Sealing flange and rotor are pressed together with three M6 x 35 mm screws from the crankshaft.*

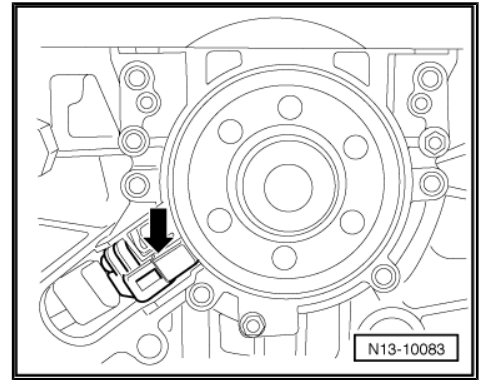

- Screw three screws M6x35 into the threaded bores of the sealing flange -arrows-.
- Screw the screws alternately (max 1/2 turn (180°) per screw) in the sealing flange and press the sealing flange together with the rotor from the crankshaft.

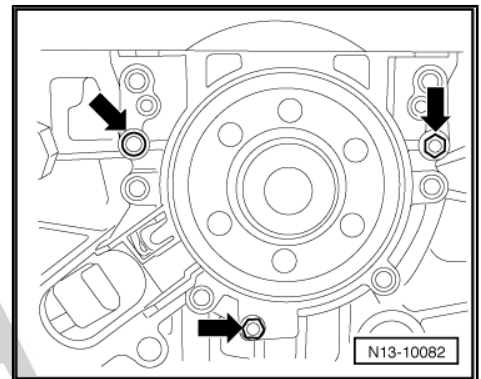

### 3.5.2 Install

**i** Note

- ◆ *The sealing flange with PTFE gasket ring is provided with sealing lip supporting ring. This supporting ring is intended as an assembly sleeve and must not be removed before installing.*
- ◆ *Do not separate or turn the sealing flange and rotor after removing them from the spare part package.*
- ◆ *The rotor is given its fitting location by fixing the assembly tool -T10134- to the positioning pin.*
- ◆ *The sealing flange and gasket ring form one unit and must be replaced together with the rotor.*
- ◆ *The assembly tool -T10134- is given its fitting location to the crankshaft by means of a guide bolt, which is guided into a hole of the crankshaft.*

Protected by copyright. Copying for private or commercial purposes, in part or in whole, is not permitted. SKODA AUTO A. S. SKODA AUTO A. S. does not guarantee or accept any liability with respect to the correctness of information in this document. Copyright by SKODA AUTO A. S.

#### Assembly tool -T10134-

- A - Hexagon nut
- B - Clamping surface
- C - Assembly cup
- D - Allan screw
- E - Guide bolts (with red handle - for fuel engine)
- F - Positioning pin
- G - Guide bolts (with black handle - for diesel engine)

**A - Mounting sealing flange with rotor on the assembly tool -T10134-**

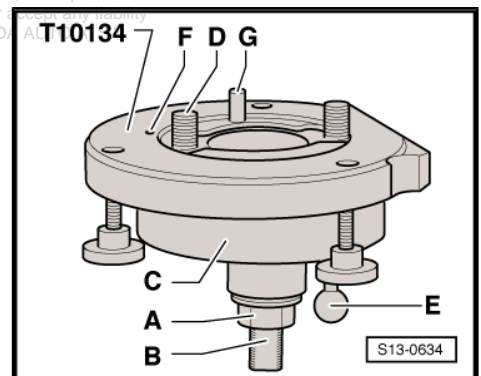



- Screw the hexagon nut -A- right up to the clamping surface -B- and grip the assembly tool -T10134- on the clamping surface -B- of the threaded spindle in a vice.

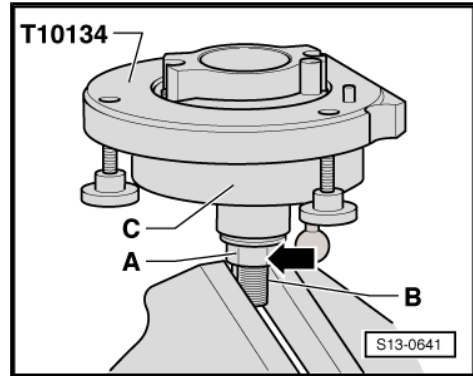

- Remove the securing clip -arrow- from the new sealing flange.



**Note**

*Do not remove or turn the rotor from the sealing flange.*

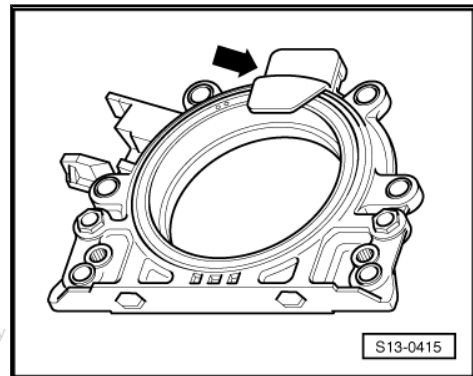

Protected by copyright. Copying for private or commercial purposes, in part or in whole, is not permitted unless authorised by ŠKODA AUTO A. S. ŠKODA AUTO A. S. does not guarantee or accept any liability with respect to the correctness of information in this document. Copyright by ŠKODA AUTO A. S. ©

- Lay the front side of the sealing flange on a clean and level surface.
- Press down sealing lips supporting ring -A- in -direction of the arrow-, until it rests on the level surface.



**Note**

*The top edge of the rotor and the front edge of the sealing flange must be flush.*

- The locating hole -B- on the rotor -C- must be flush with the marking -A- on the sealing flange.

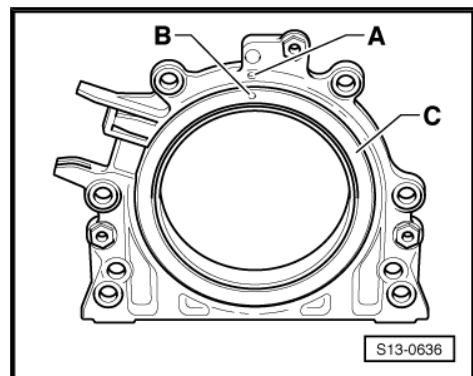
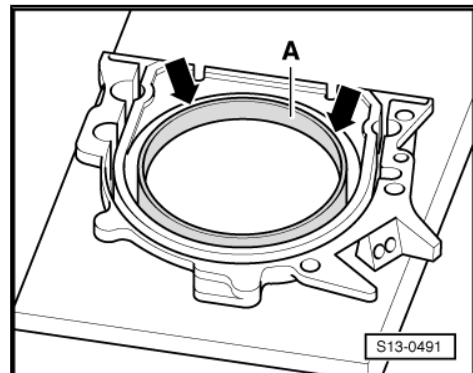



- Lay the sealing flange with the front side on the assembly tool -T10134- in such a way that the positioning pin -A- engages into the hole -B- of the rotor.



**Note**

*Make sure the sealing flange lies flat on the assembly tool.*

- When tightening the knurled screws -A- press the sealing lip supporting ring -B- on the surface of the assembly tool in such a way that the positioning pin cannot slide out of the rotor hole.

**B - Mount the assembly tool -T10134- on the crankshaft flange**

- The crankshaft flange must be free of grease and oil
- Crankshaft is at TDC for cylinder 1
- Unscrew hexagon nut up to the end of the threaded spindle.

- Screw assembly tool -T10134- with Allan screws -A- up to the stop onto the crankshaft flange.

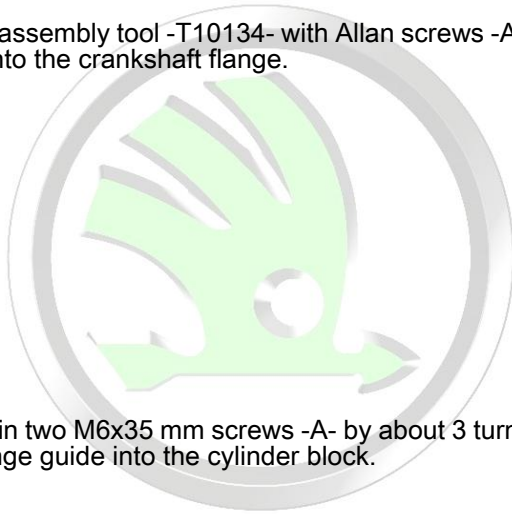

- Screw in two M6x35 mm screws -A- by about 3 turns for sealing flange guide into the cylinder block.

Protected by copyright. Copying for private or commercial purposes, in part or in whole, is not permitted unless authorised by ŠKODA AUTO A. S. ŠKODA AUTO A. S. does not guarantee or accept any liability with respect to the correctness of information in this document. Copyright by ŠKODA AUTO A. S.®

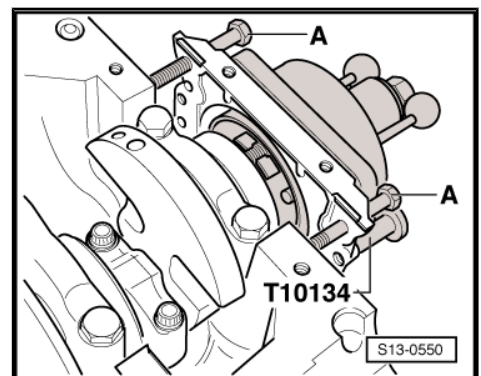
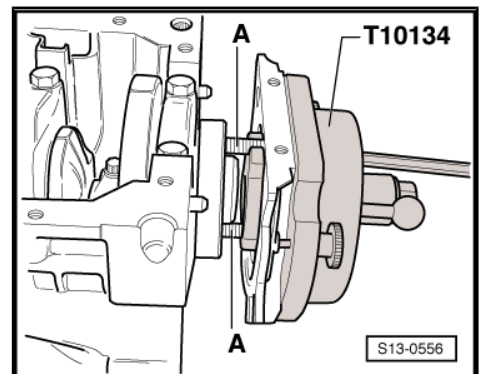
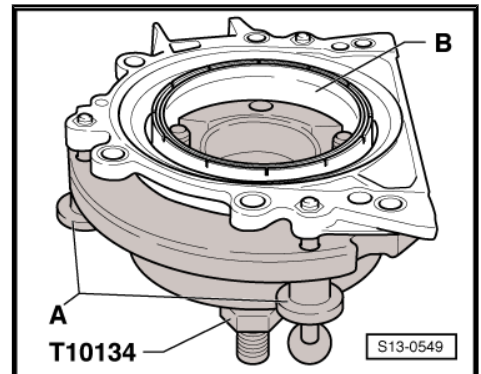
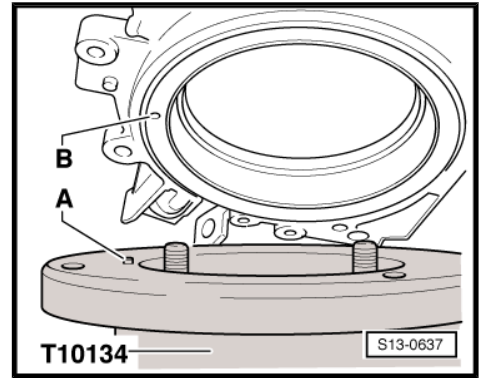



- Move the assembly cup -C- by hand in the -direction of the arrow- until the rotor -B- rests on the crankshaft flange -A-. Subsequently insert the guide bolt with red ball -F- fully into the threaded bore of the crankshaft. If the guide bolt is correctly pushed in, then the handle has a distance of approx. 10 mm from the assembly cup -C-. This gives the rotor its final fitting location.

**C - Pressing the rotor onto the crankshaft flange**

- Screw in hexagon nut by hand onto the threaded spindle until it rests against the assembly cup.

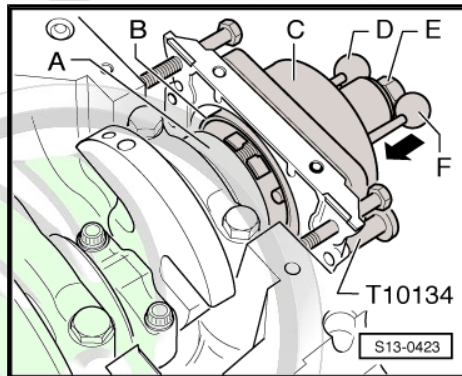

- Tighten the hexagon nut of the assembly tool using a torque wrench with adapter.

Tightening torque: 35 Nm.

**i Note**

*After tightening the nut to 35 mm there must still be a narrow air gap between the cylinder block and the sealing flange.*

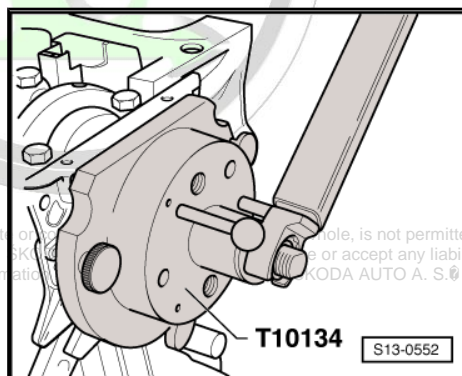

**D - Inspecting the fitting position of the rotor on the crankshaft**

- Unscrew hexagon nut -E- up to the end of the threaded spindle.
- Unscrew two M6x35 mm screws -A- from the cylinder block.
- Unscrew three knurled screws -B- from the sealing flange.
- Unscrew two Allan screws and remove assembly tool - T10134- .
- Remove sealing lips supporting ring.

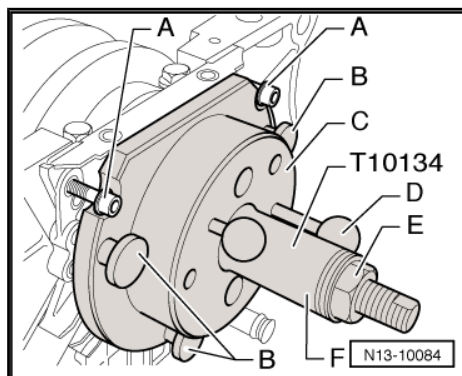

The fitting position of the rotor on the crankshaft is accurate if there is a distance -a- of 0.5 mm between the crankshaft flange -A- and the rotor -B-.

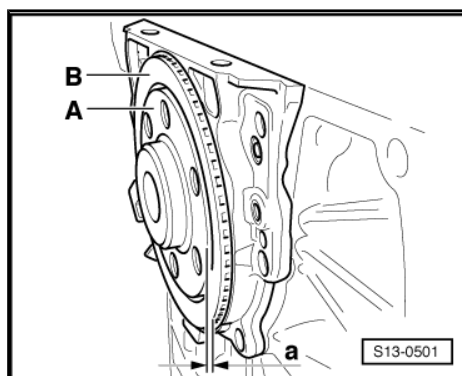



- Position the steel straightedge onto the crankshaft flange.
- Measure the distance between the steel straightedge and the rotor with a feeler gauge.

If the measured distance is less than 0.5 mm:

- Press down rotor => [page 49](#) .

If the dimension is correct:

- Tighten the new fixing screws of the sealing alternately cross-wise.

Tightening torque: 10 Nm.

- Install engine speed sender -arrow-.

Tightening torque: 5 Nm.

- Installing the oil pan => [page 93](#) .
- Installing intermediate plate.
- Install flywheel with new screws.

### E - Pressing down the rotor

- Screw assembly tool -T10134- with Allan screws up to the stop onto the crankshaft flange.
- Screw in three knurled screws -A- into the flange.
- Subsequently insert the guide bolt with red ball -E- fully into the threaded bore of the crankshaft. If the guide bolt is correctly slipped on, then the handle has a distance of approx. 10 mm from the assembly cup -B-.

- Tighten the hexagon nut of the assembly tool using a torque wrench with adapter.

Tightening torque: 40 Nm.

- Again inspect the fitting position of the rotor on the crankshaft => [page 48](#) .

If the dimension -a- is again too small:

- Tighten the hexagon nut of the assembly tool to 45 Nm.
- Again inspect the fitting position of the rotor on the crankshaft => [page 48](#) .

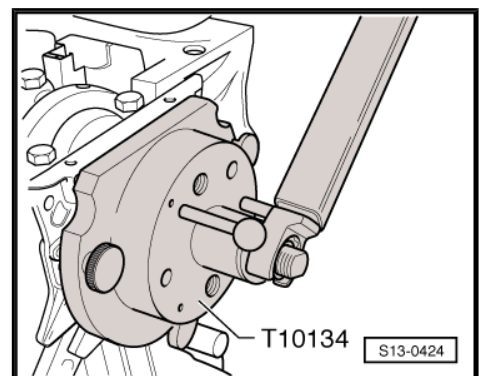
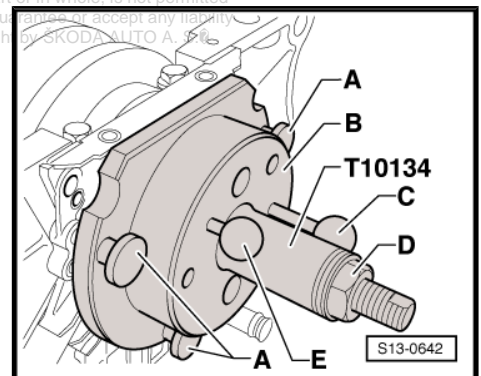
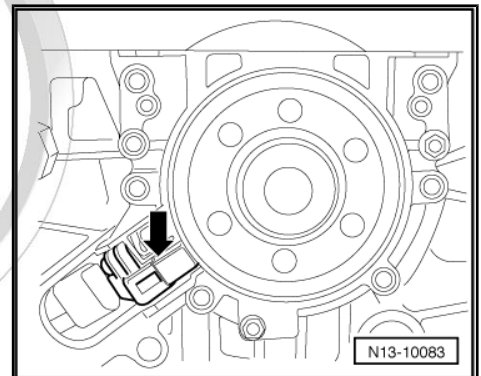
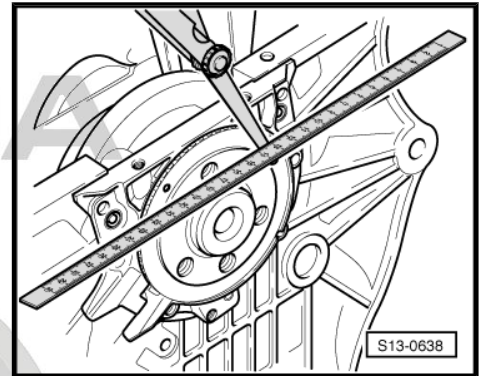



## 4 Crankshaft



### Caution

*The crankshaft must not be removed. Merely releasing the screws of the crankshaft bearing cover will result in deformations of the bearing seats of the cylinder block. These deformations will reduce the bearing clearance. If the bearing shells are not replaced, the changed bearing clearance may cause damage to the bearing.*

*If the bearing cover screws have been released, replace the complete cylinder block together with the crankshaft.*

*It is not possible to measure the crankshaft bearing clearance with workshop tools.*

### 4.1 Replace needle bearing for crankshaft

Only on vehicles equipped with automatic gearbox.

#### Special tools and workshop equipment required

- ◆ Centering mandrel -T30029 (3176)-
- ◆ Interior extractor -Kukko 21/2-
- ◆ Countersupport - Kukko 22/1-

#### Removing

- Pull out needle bearing with interior extractor -Kukko 21/2- and countersupport -Kukko 22/1- .

#### Install



#### Note

*The marked side of the needle bearing should be legible when in its installed condition.*

- Drive in the needle bearing using the centering pin -T30029- .
- Fitting position: The marked side of the needle bearing should be legible when in its installed condition.

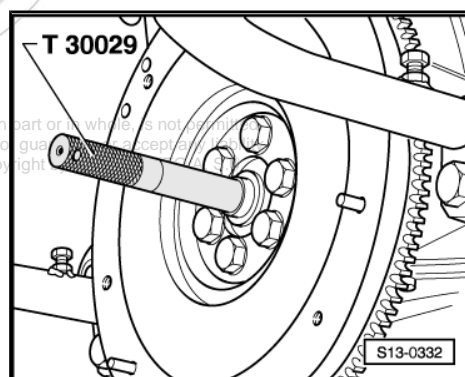
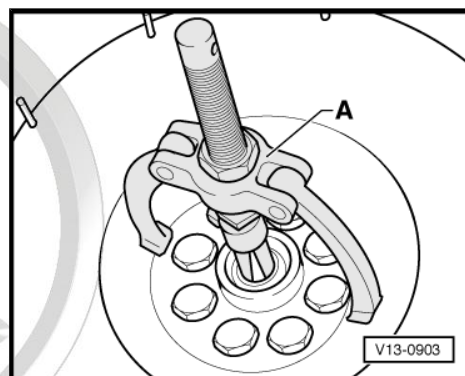

Protected by copyright. Copying for private or commercial purposes, in part or in whole, is not permitted unless authorised by ŠKODA AUTO A. S. ŠKODA AUTO A. S. does not guarantee the accuracy of the information with respect to the correctness of information in this document. Copyright © 2010 ŠKODA AUTO A. S.



Depth of installation of the needle bearing

- Dimension -a-: 1.5 up to 1.8 mm

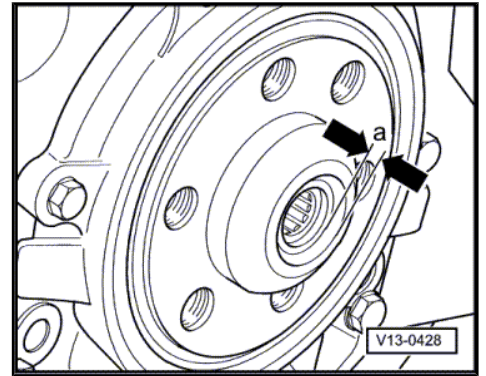

ŠKODA



Protected by copyright. Copying for private or commercial purposes, in part or in whole, is not permitted unless authorised by ŠKODA AUTO A. S. ŠKODA AUTO A. S. does not guarantee or accept any liability with respect to the correctness of information in this document. Copyright by ŠKODA AUTO A. S. ©



## 5 Pistons and conrods

### 5.1 Summary of components



#### Note

Before assembly oil all bearing and contact surfaces.

#### 1 - Circlip

#### 2 - Piston pin

- if stiff, heat piston to 60° C
- use drift -T10046- for removing and installing

#### 3 - Piston

- check ⇒ [page 54](#)
- mark installation position and matching cylinder
- arrow on the piston crown faces towards the belt pulley side
- use piston ring tensioning strap for installing
- Piston Ø: 70.95 mm (nominal dimension)
- Cylinder Ø: 71.00 mm (nominal dimension)

#### 4 - Compression rings

- Offset joint 120°
- use piston ring pliers for removing and installing compression rings
- Marking „TOP“ faces piston crown
- Inspect gap clearance ⇒ [page 53](#)
- Inspect end clearance ⇒ [page 53](#)

#### 5 - Oil scraper rings

- carefully remove and install 3-part oil scraper rings by hand
- Inspect gap clearance ⇒ [page 53](#)
- End clearance cannot be measured

#### 6 - 30 Nm + torque a further 90° (1/4 turn)

- replace
- Oil thread and contact surface

#### 7 - Conrod bearing cap

- as a result of the conrods separated in the cracking process, the cover fits only in one position and only to the relevant conrod
- Mark the assignment of the cylinder before removal -A-

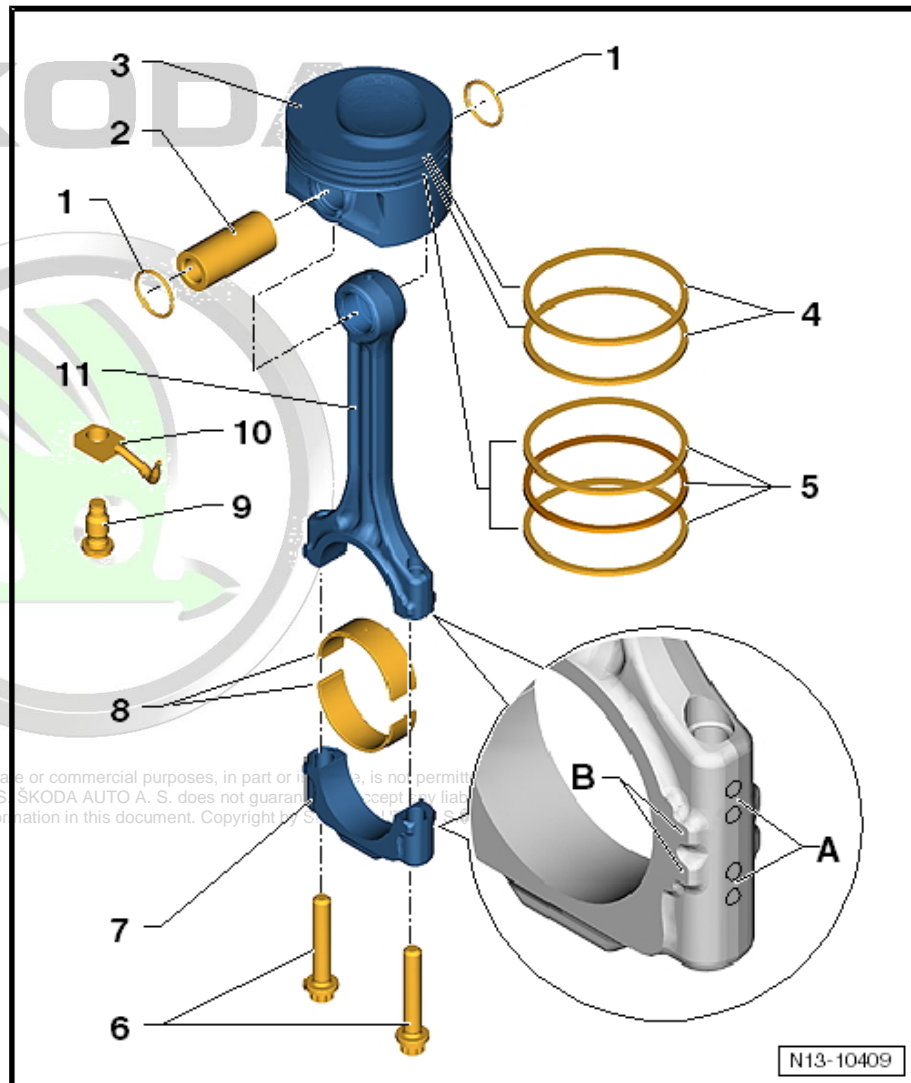

- Fitting position: Marking -B- points to the belt pulley side (mark before removing if marking is missing)

### 8 - Bearing shell

- do not mix up used bearing shells
- insert bearing shells in the centre

### 9 - Pressure relief valve, 27 Nm

- Opening pressure: 0.2 MPa (2.0 bar)

### 10 - Oil injection nozzle

- for piston cooling
- Align the guide edge of the oil injection nozzle -arrow- to the area of the cylinder block being worked on.

### 11 - Conrod

- always replace as a set only
- mark matching cylinder -A-
- Fitting position: Marking -B- points to the belt pulley side (mark before removing if marking is missing)
- located axially by pistons
- separate new conrod ⇒ [page 55](#)

## 5.2 Inspect piston, piston rings and cylinder bore

### Inspecting piston ring gap clearance

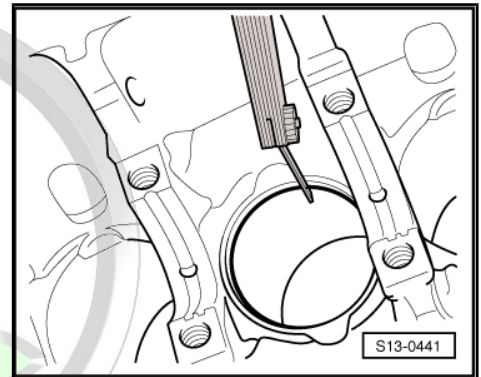

### Special tools and workshop equipment required

- ◆ Feeler gauge
- Insert ring at right angles from above down into lower cylinder opening, about 15 mm away from edge of cylinder.

Piston ring dimensions in mm	New	Wear limit
1. Compression ring	0,20...0,40	1,0
2. Compression ring	0,40...0,60	1,0
Oil scraper ring	0,25...0,75	no wear indication possible

### Inspect piston ring end clearance

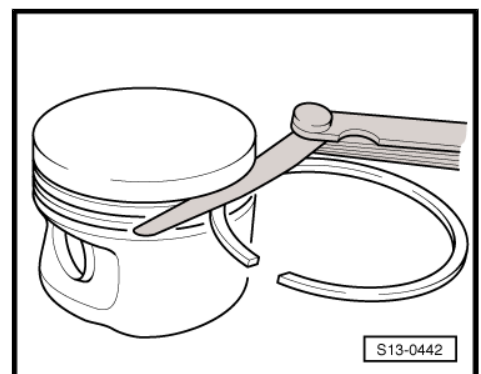

### Special tools and workshop equipment required



- ◆ Feeler gauge
- Clean ring groove before inspecting.

Piston ring dimensions in mm	New	Wear limit
1. Compression ring	0,03...0,09	0,15
2. Compression ring	0,02...0,06	0,15
Oil scraper ring	cannot be measured	

**Inspecting pistons**

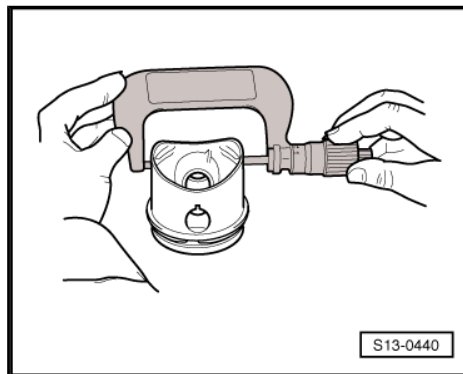

**Special tools and workshop equipment required**

- ◆ External micrometer 75...100 mm
- Measure about 7 mm from the lower edge and offset 90° to piston pin axis.
- Deviations from specified dimension: max. 0.04 mm

**Inspecting cylinder bore**

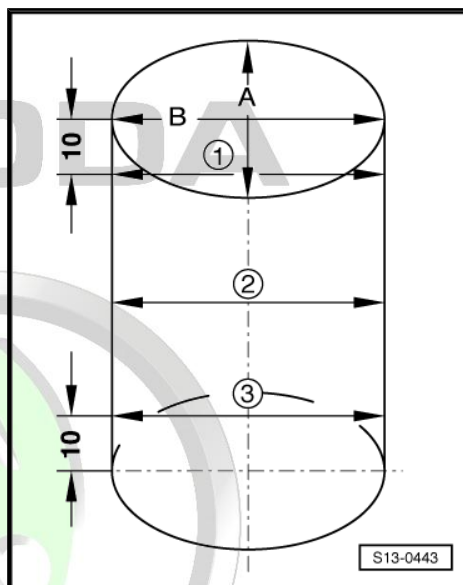

**Special tools and workshop equipment required**

- ◆ Internal precision measuring instrument 50...100 mm
- Measure at 3 points crosswise in a transverse direction -A- and lengthwise -B-.
- Deviations from specified dimension: max. 0,08 mm

Protected by copyright. Copying for private or commercial purposes, in part or in whole, is not permitted unless authorised by ŠKODA AUTO A. S. ŠKODA AUTO A. S. does not guarantee or accept any liability with respect to the correctness of information in this document. Copyright by ŠKODA AUTO A. S. ©

**i** Note

*Do not measure the cylinder bore if the cylinder block is fixed to the assembly stand -MP 1-202- with the engine mount -MP 9-101 -, as this may result in incorrect measurements.*

### 5.3 Separating new conrod

It can happen that the predetermined breaking point on the new conrod is not completely pierced. If the conrod bearing cap cannot be removed by hand, then proceed as follows:

- Mark the assignment of the conrod to the cylinder.
- Slightly tension the conrod in a vice provided with aluminium protective jaws, as shown in the illustration.

**i** Note

- ◆ *Only tension the conrod slightly in order to avoid damage.*
- ◆ *The conrod is clamped below the broken line.*
- Unscrew both screws -arrows- by approx. 5 turns.

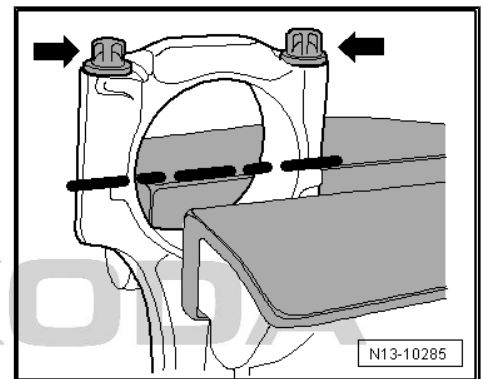

- Carefully knock against the conrod bearing cap with a rubber hammer in -direction of arrow- in order to loosen it.

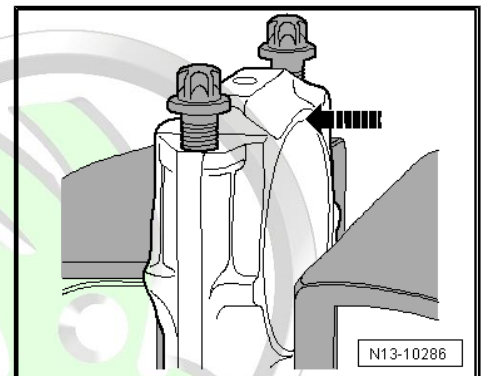

Protected by copyright. Copying for private or commercial purposes, in part or in whole, is not permitted unless authorised by ŠKODA AUTO A. S. ŠKODA AUTO A. S. does not guarantee or accept any liability with respect to the correctness of information in this document. Copyright by ŠKODA AUTO A. S. ©



## 15 – Cylinder head, valve gear

### 1 Cylinder head - part 1

#### 1.1 Summary of components

Testing compression pressure ⇒ [page 83](#) .



#### Note

- ◆ *When installing a replacement cylinder head, all the contact surfaces between the hydraulic balancing elements, the cam followers and the cam tracks must be oiled before installing the cylinder head cover.*
- ◆ *Do not remove the plastic bases supplied as a protection for the open valves until just before fitting on the cylinder head.*
- ◆ *If the cylinder head is replaced, also the entire coolant must be replaced.*
- ◆ *Before assembly moisten all bearing and contact surfaces with oil.*
- ◆ *Removing and installing intake manifold ⇒ [page 169](#) .*

Protected by copyright. Copying for private or commercial purposes, in part or in whole, is not permitted unless authorised by ŠKODA AUTO A. S. ŠKODA AUTO A. S. does not guarantee or accept any liability with respect to the correctness of information in this document. Copyright by ŠKODA AUTO A. S. ©

1 - 8 Nm

**2 - High pressure pump**

- for fuel supply
- with fuel pressure regulating valve -N276-
- removing and installing ⇒ [page 173](#)

3 - 10 Nm

**4 - Hall sender -G40-**

- with O-ring
- replace the O-ring if it is damaged

5 - 20 Nm

**6 - Lifting eye**

**7 - 8 Nm + torque a further 90° (1/4 turn)**

- replace
- order of tightening ⇒ [page 73](#)

**8 - Cylinder head cover**

- removing and installing ⇒ [page 73](#)

9 - 10 Nm

**10 - Coolant temperature sender -G62-**

- before removing, reduce pressure in cooling system

**11 - O-ring**

- replace

**12 - Cylinder head gasket**

- replace
- metal gasket
- after replacing fill entire system with fresh coolant

**13 - Cylinder head**

- removing and installing ⇒ [page 81](#)
- check for distortion ⇒ [page 58](#)
- Sealing surfaces must be free of oil and grease
- after replacing fill entire system with fresh coolant

**14 - Hydraulic balancing element**

- do not interchange
- with hydraulic valve clearance compensation
- oil contact surfaces

**15 - Oil pressure switch -F1- , 20 Nm**

- check ⇒ [page 96](#)
- Cut open gasket ring if leaking and replace

**16 - Roller rocker arm**

- inspect roller bearings for smooth operation
- oil contact surfaces

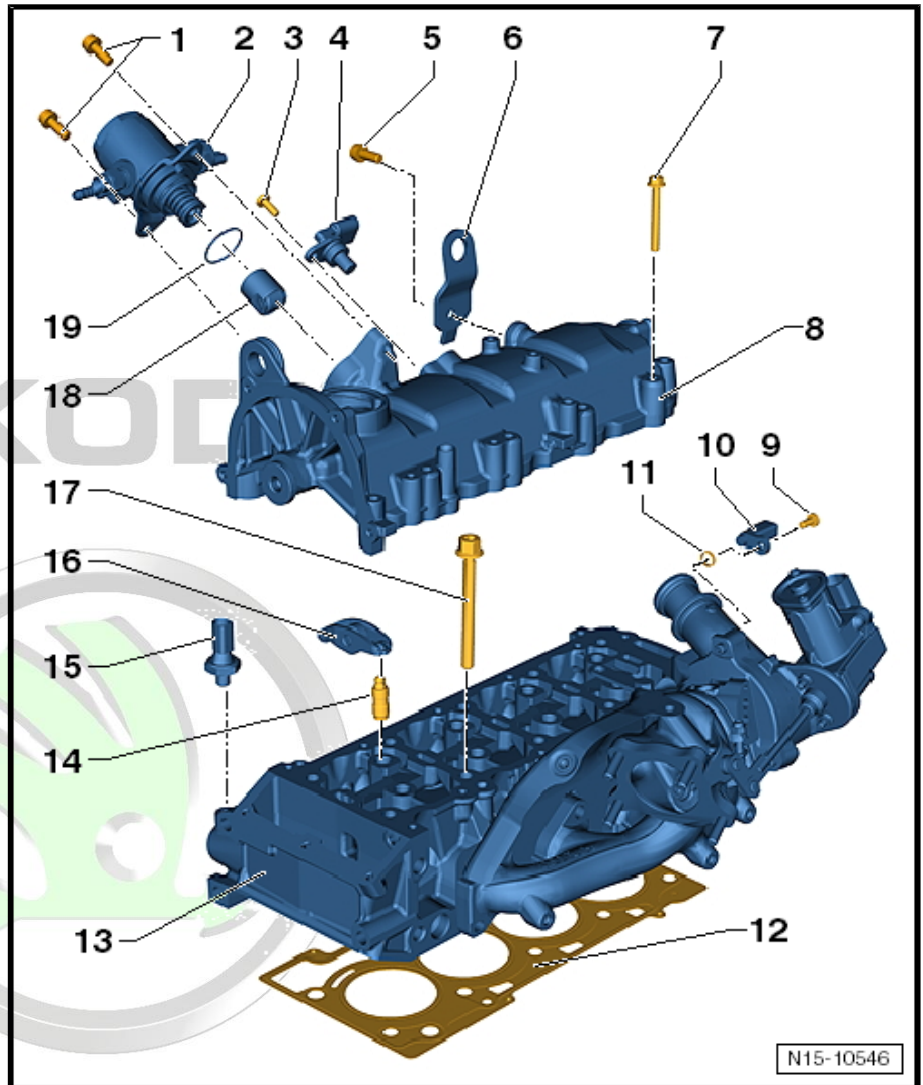

Copyright by ŠKODA AUTO A. S. Copying for private or commercial purposes, in part or in whole, is not permitted unless authorised by ŠKODA AUTO A. S. ŠKODA AUTO A. S. does not guarantee or accept any liability for the correctness of the information in this document. Copyright by ŠKODA AUTO A. S. ®



- for installing, clip onto the balancing element with the locking clip

### 17 - Cylinder head bolt

- replace
- observe the mounting instructions and sequence for loosening and tightening ⇒ [page 81](#)

### 18 - Roller tappet

- Lightly moisten the contact surface with engine oil

### 19 - O-ring

- replace
- moisten with oil before inserting

### Inspecting the cylinder head for distortion

Check with straightedge 500 mm , e. g. -VAS 6075- and feeler gauge.

- Max. permissible distortion: 0.05 mm

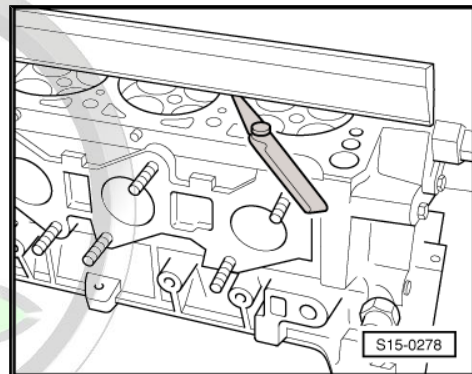

## 1.2 Test timing

### Special tools and workshop equipment required

- ◆ Fixing bolts -T10414-
  - ◆ Locating screw -T10340-
- Protected by copyright. Copying for private or commercial purposes, in part or in whole, is not permitted unless authorised by ŠKODA AUTO A. S. ŠKODA AUTO A. S. does not guarantee or accept any liability with respect to the correctness of information in this document. Copyright by ŠKODA AUTO A. S. ©

### Test sequence

#### Vehicles with auxiliary heating.

- Unscrew the screws -1 and 2- of the brackets for the coolant pipes for the auxiliary heating -3-.

#### Continued for all vehicles

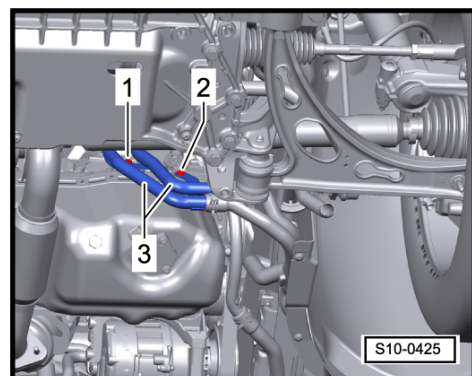

- Release fixing screws -1- and remove bracket for coolant pipe -2-.

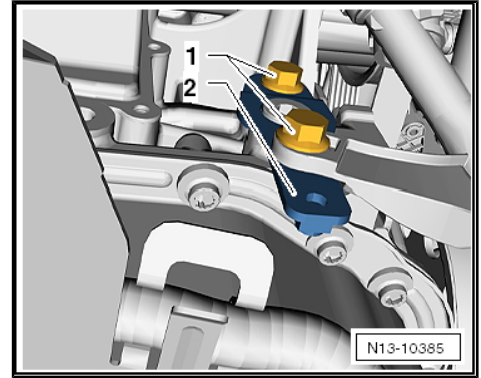

- Release screw plug -arrow- at cylinder block.

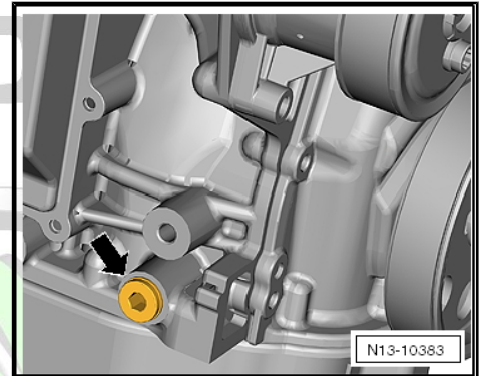

- Turn the fixing screw -T10340- up to the stop in the cylinder block.

**Caution**  
*If the fixing screw -T10340- cannot be screwed in up to the stop, the crankshaft is not in the correct position!  
In this case proceed as described below.*

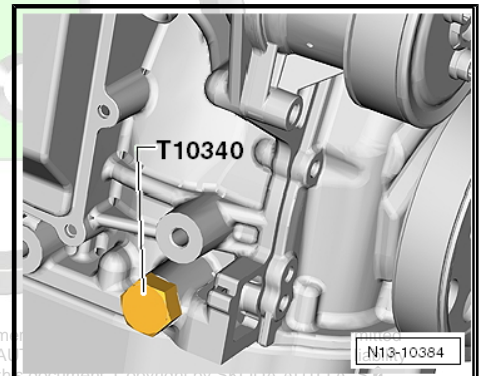

- Unscrew the fixing screw.
- Turn crankshaft 90° (1/4 turn) in direction of rotation of engine.
- Turn the fixing screw -T10340- up to the stop in the cylinder block.
- Tighten fixing screw -T10340- to 30 Nm.
- Turn crankshaft up to the stop in direction of rotation of engine.

The crankshaft is locked in direction of rotation of engine with the fixing screw -T10340- .

- Pull off both coolant hoses -1- from the non-return valve.
- Release the fixing screw -2- and pull the non-return valve out of the cylinder head cover.

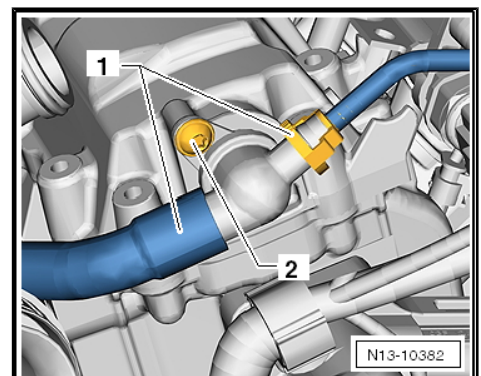



The grooves in the camshaft -arrows- must be in the position shown.

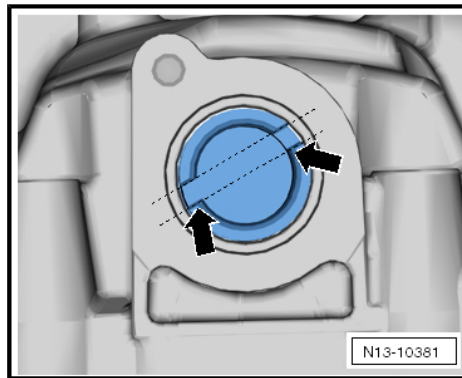

- Insert the fixing bolt -T10414- up to the stop into the cylinder head cover.

If the fixing bolt -T10414- cannot be inserted up to the stop into the camshaft opening, the timing is not correct and must be set ⇒ [page 60](#) .

The timing is O.K., if the fixing bolt -T10414- can be pushed up to the stop into the cylinder head cover.

- Remove fixing bolt -T10414- and fixing screw -T10340- .

Further installation occurs in a similar way in reverse order to removal.

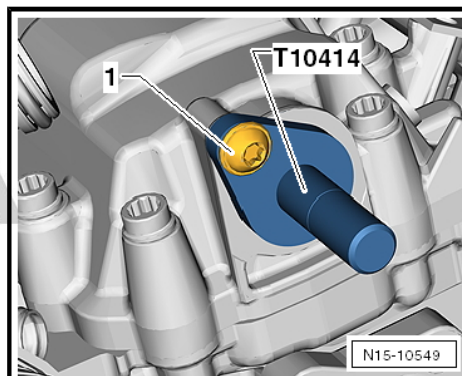

### 1.3 Setting the timing

#### Special tools and workshop equipment required

- ◆ Fixing bolts -T10414-
- ◆ Locating screw -T10340-
- ◆ Counterholder -T10172 -

#### Work procedure

- Drain coolant ⇒ [page 99](#) .
- Remove top timing case ⇒ [page 33](#) .
- Pull off both coolant hoses -1- from the non-return valve.
- Release the fixing screw -2- and pull the non-return valve out of the cylinder head cover.

Vehicles with auxiliary heating.

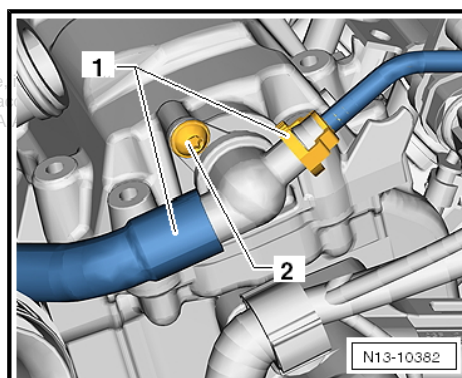



- Unscrew the screws -1 and 2- of the brackets for the coolant pipes for the auxiliary heating -3-.

Continued for all vehicles

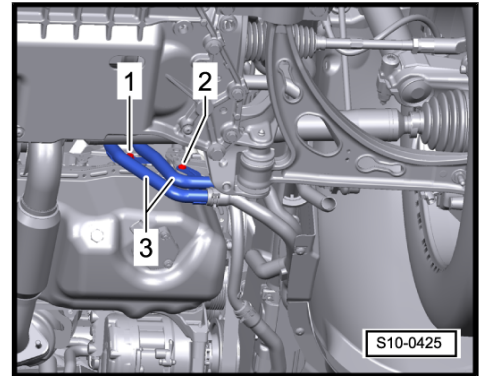

- Release fixing screws -1- and remove bracket for coolant pipe -2-.

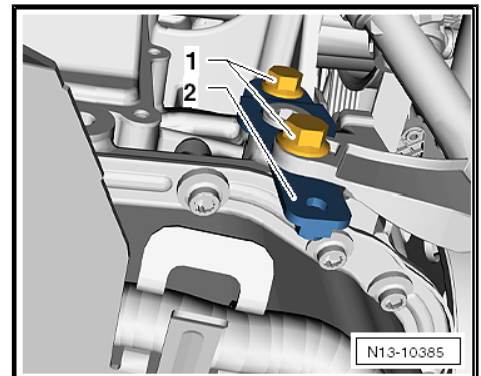

- Release screw plug -arrow- at cylinder block.

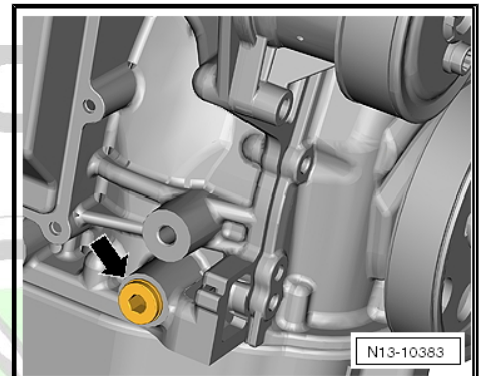

Protected by copyright. Copying for private or commercial purposes, in part or in whole, is not permitted unless authorised by ŠKODA AUTO A. S. ŠKODA AUTO A. S. does not guarantee or accept any liability with respect to the correctness of information in this document. Copyright by ŠKODA AUTO A. S. ©



- Turn the fixing screw -T10340- up to the stop in the cylinder block.



**Caution**

*If the fixing screw -T10340 - cannot be screwed in up to the stop, the crankshaft is not in the correct position!*

*In this case proceed as described below.*

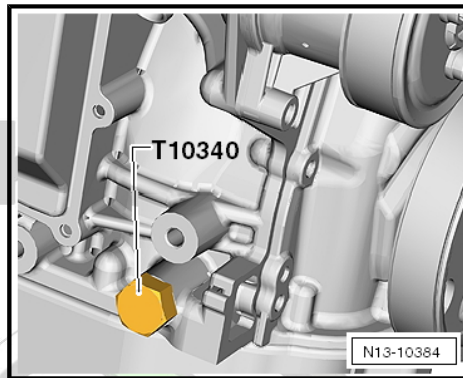

- Unscrew the fixing screw.
- Turn crankshaft 90° (1/4 turn) in direction of rotation of engine.
- Turn the fixing screw -T10340- up to the stop in the cylinder block.
- Tighten fixing screw -T10340- to 30 Nm.
- Turn crankshaft up to the stop in direction of rotation of engine.

The crankshaft is locked in direction of rotation of engine with the fixing screw -T10340- .

- Removing the oil pan ⇒ [page 93](#) .
- Pull off the cover -1- from the oil pump.

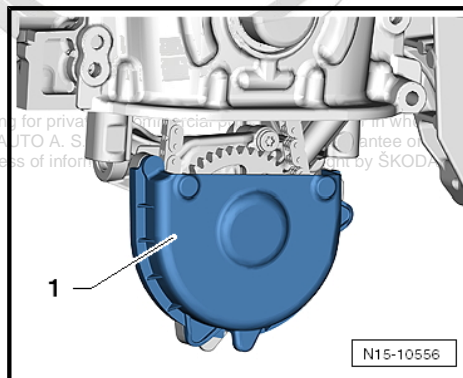

Protected by copyright. Copying for private or commercial purposes in whole or in part is not permitted unless authorised by ŠKODA AUTO A. S. ŠKODA AUTO A. S. does not accept any liability for any damage with respect to the correctness of information contained in this document by ŠKODA AUTO A. S. ©

- Release chain tensioner -arrow- for timing chain.

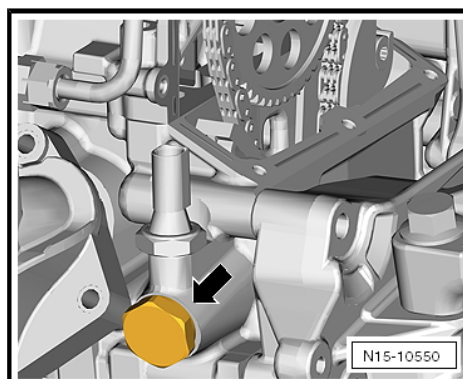



- Hold the camshaft sprocket with the counterholder -T10172- and slacken the fixing screw -1- of the camshaft sprocket.
- Remove the camshaft sprocket together with the fixing screw.

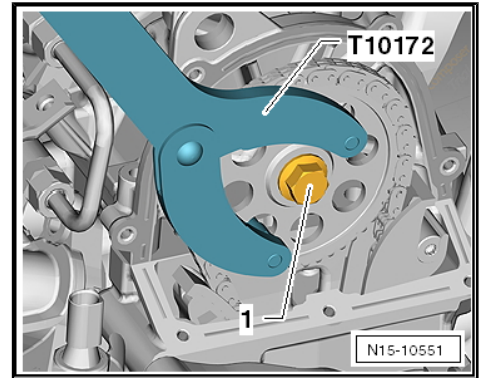

- Place the chain sprocket -1- down on the integrated peg -arrow- in the timing case.

**i** Note

*The integrated peg on the inner side of the timing case prevents the chain sprocket from falling down.*

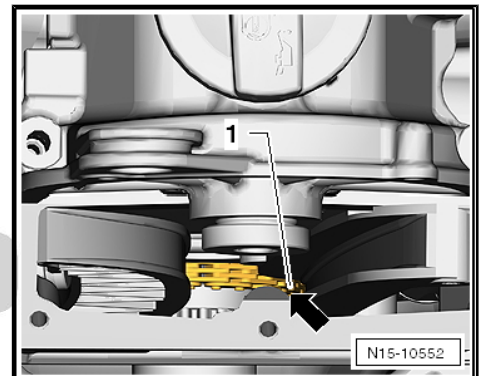

- Position the camshaft sprocket -1- on the camshaft and tighten the fixing screw -2- to 50 Nm.
- Hold the camshaft sprocket with the counterholder -T10172- when tightening.
- Then turn back the crankshaft 90° (1/4 turn) in the opposite direction of rotation of the engine.

**i** Note

*When subsequently adjusting the camshaft, damage to the valves is prevented by turning the crankshaft in the opposite direction of rotation of the engine.*

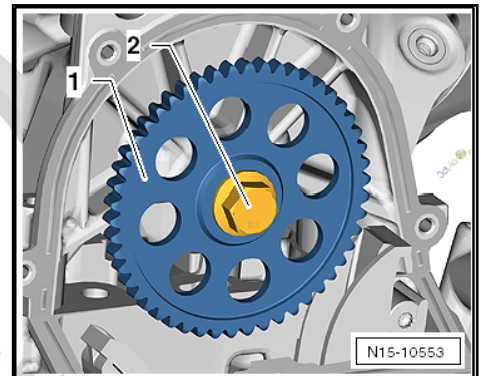

- Turn the camshaft until the grooves -arrows- are in the position shown.

Protected by copyright. Copying for private or commercial purposes, in part or in full, is prohibited unless authorised by ŠKODA AUTO A. S. ŠKODA AUTO A. S. does not accept any liability with respect to the correctness of information in this document. Copyright © 2010 ŠKODA AUTO A. S.

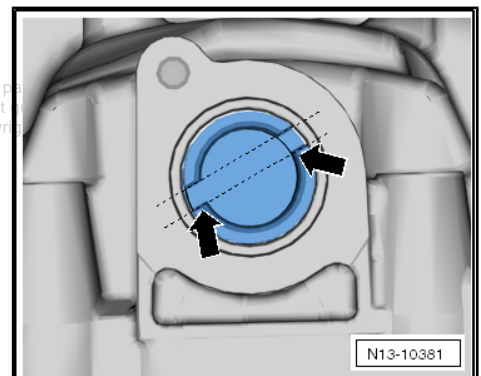



- Insert the fixing bolt -T10414- up to the stop into the cylinder head cover.
- Tighten fixing screw -1- by hand.
- Turn crankshaft up to the stop in direction of rotation of engine.

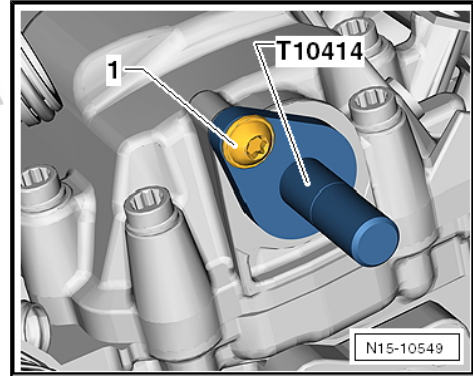

- Lift up the timing chain with the assembly device -T10118- .

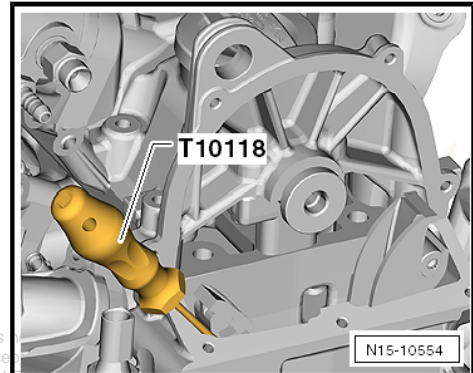

Protected by copyright. Copying for private or commercial purposes, in part or in whole, is unless authorised by ŠKODA AUTO A. S. ŠKODA AUTO A. S. does not guarantee or accept responsibility with respect to the correctness of information in this document. Copyright by ŠKODA AUTO A. S.

- Check the correct position of the timing chain -1- on the crankshaft gear from below.

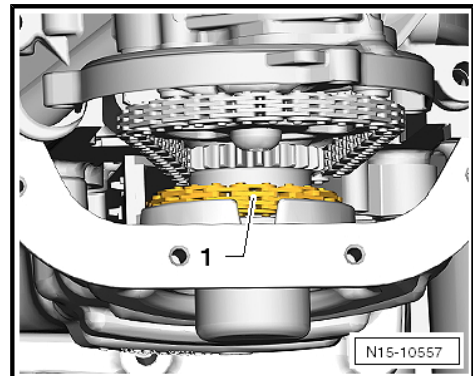

- Place the timing chain -1- onto the chain sprocket -2-.
- The timing chain must rest in the area of the sliding rail -3- and be slightly tensioned.

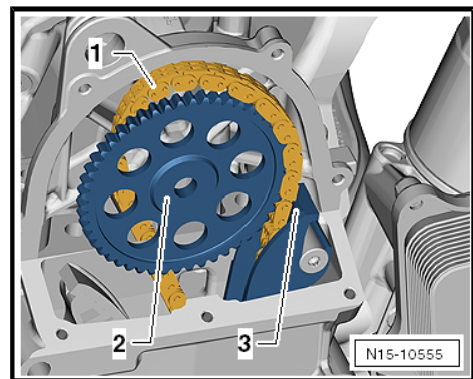

- Hold the camshaft sprocket with the counterholder -T10172- and tighten the fixing screw -1- of the camshaft sprocket to 50 Nm.

 **Note**

*The fixing screw is only turned a further 90° (1/4 turn) after checking the timing at the end of the work procedure.*

- Install chain tensioner and tighten to 60 Nm.
- Remove the fixing bolt -T10414- from the camshaft.
- Release the fixing screw -T10340- from the cylinder block.
- Turn the crankshaft in direction of rotation of engine by 2 turns.
- Turn the fixing screw -T10340- up to the stop in the cylinder block.
- Turn crankshaft up to the stop in direction of rotation of engine.

The timing is O.K., if the fixing bolt -T10414- can be inserted in the camshaft.

If the timing is not O.K., the setting of the timing must be repeated.

- Hold the camshaft sprocket with the counterholder -T10172- and torque the fixing screw -1- a further 90° (1/4 turn).
- Remove fixing bolt -T10414- and fixing screw -T10340- .
- Install top timing case ⇒ [page 33](#) .

- Install non-return valve. Tightening torque of the fixing screw -2-: 8 Nm.
- Fit on hoses -1-.
- Installing the oil pan ⇒ [page 93](#) .

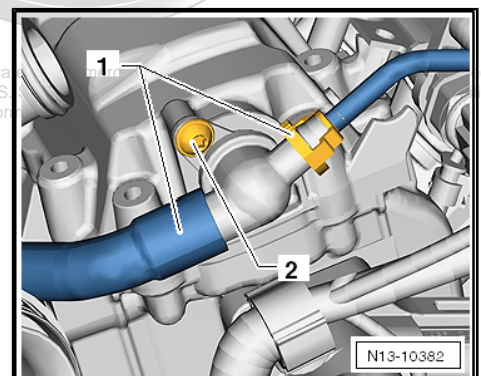
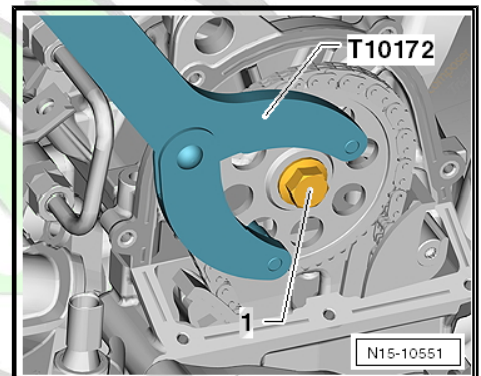
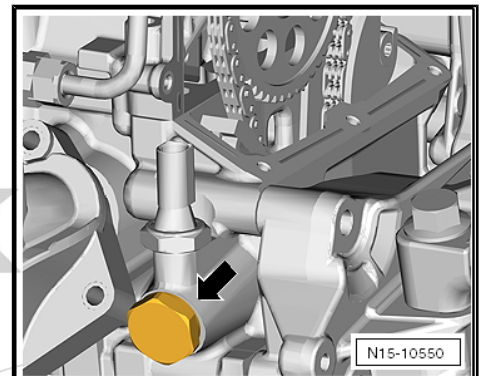
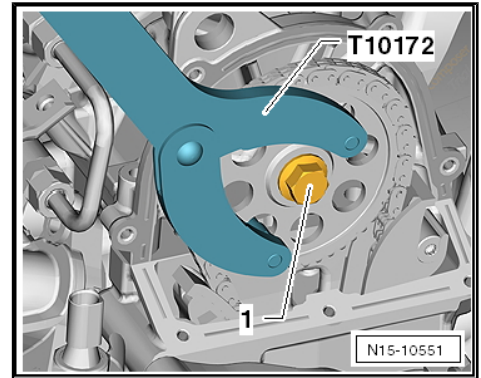

Protected by copyright. Copying for private use is permitted without the need for permission, unless authorised by ŠKODA AUTO A. S. with respect to the correctness of information.



- Install screw plug. Tightening torque: 30 Nm
- Top up coolant ⇒ [page 99](#) .

Further installation occurs in a similar way in reverse order to removal.

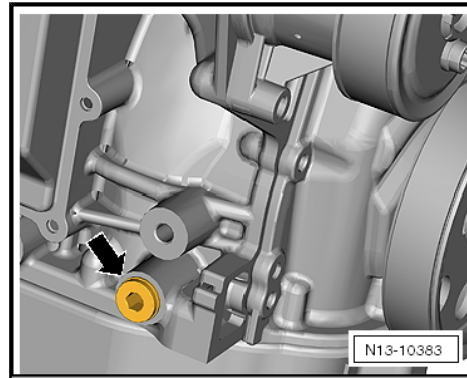

## 1.4 Removing and installing timing chain and drive chain for oil pump



### Note

*First of all, the timing chain must be removed in order to remove the drive chain for oil pump.*

Remove timing chain ⇒ [page 66](#)

Remove and install the drive chain for oil pump ⇒ [page 70](#)

Install timing chain ⇒ [page 71](#)

### Special tools and workshop equipment required

- ◆ Fixing bolts -T10414-
- ◆ Locating screw -T10340-
- ◆ Counterholder -T10172 -
- ◆ Counterholder -T30004 (3415)-
- ◆ Bolt -T30004/2 (3415/2)-
- ◆ Assembly device -T10417/1-

### 1.4.1 Remove timing chain

- Remove noise insulation ⇒ Body Work ⇒ Rep. gr. 50 .
- Drain coolant ⇒ [page 99](#) .
- Remove the front right wheelhouse liner ⇒ Body Work ⇒ Rep. gr. 66 .
- Remove V-ribbed belt ⇒ [page 26](#) .
- Remove top timing case ⇒ [page 33](#) .

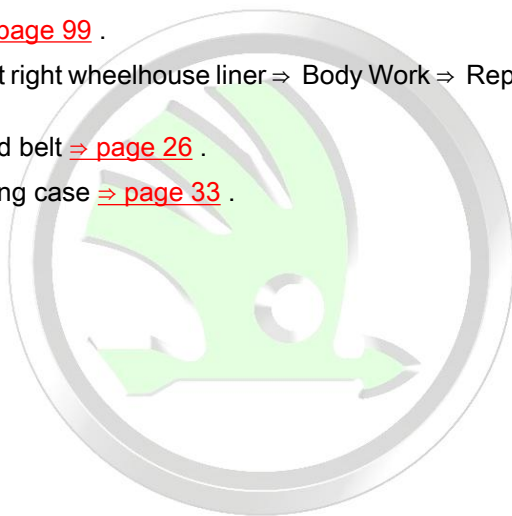



**Vehicles with auxiliary heating.**

- Unscrew the screws -1 and 2- of the brackets for the coolant pipes for the auxiliary heating -3-.

**Continued for all vehicles**

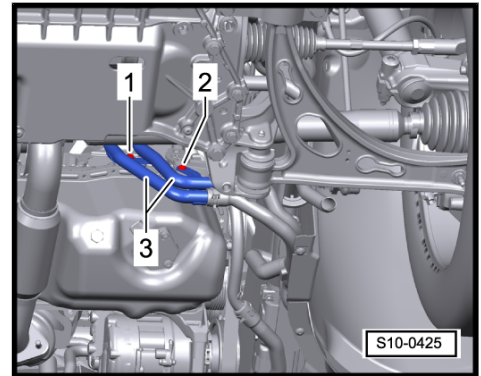

- Release fixing screws -1- and remove bracket for coolant pipe -2-.

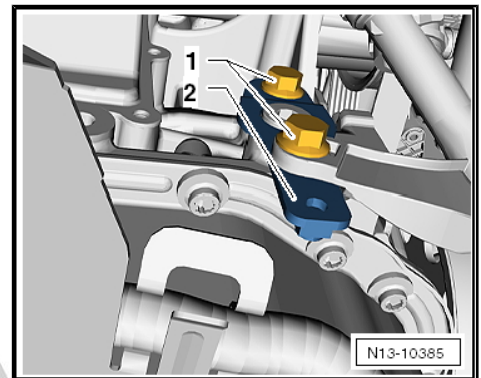

- Release screw plug -arrow- at cylinder block.

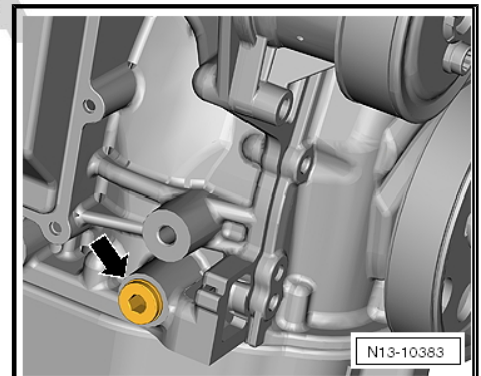

Protected by copyright. Copying for private or commercial purposes, in part or in whole, is not permitted unless authorised by ŠKODA AUTO A. S. ŠKODA AUTO A. S. does not guarantee or accept any liability with respect to the correctness of information in this document. Copyright by ŠKODA AUTO A. S.



- Turn the fixing screw -T10340- up to the stop in the cylinder block.



**Caution**

*If the fixing screw -T10340- cannot be screwed in up to the stop, the crankshaft is not in the correct position!*

*In this case proceed as described below.*

- Unscrew the fixing screw.
- Turn crankshaft 90° (1/4 turn) in direction of rotation of engine.
- Turn the fixing screw -T10340- up to the stop in the cylinder block.
- Tighten fixing screw -T10340- to 30 Nm.
- Turn crankshaft up to the stop in direction of rotation of engine.

The crankshaft is locked in direction of rotation of engine with the fixing screw -T10340- .

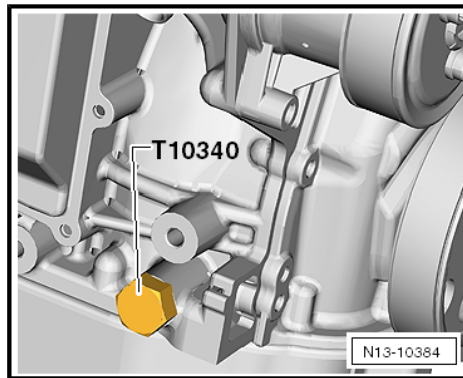

- Pull off both coolant hoses -1- from the non-return valve.
- Release the fixing screw -2- and pull the non-return valve out of the cylinder head cover.

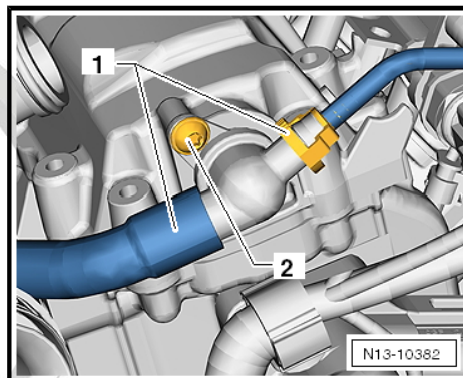

- Insert the fixing bolt -T10414- up to the stop into the cylinder head cover.
- Tighten fixing screw -1- by hand.
- Removing the oil pan ⇒ [page 93](#) .

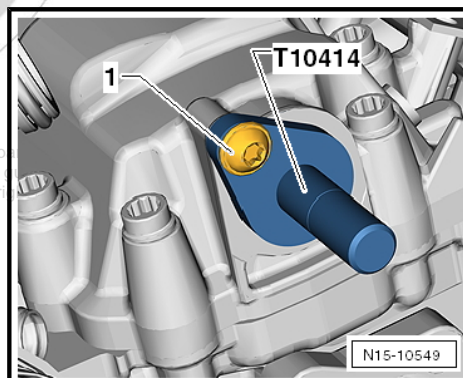

- If present, remove dust cap -1-.
- Remove guide pulley -2-.
- Remove belt pulley for coolant pump, to do so counterhold the belt pulley with the water pump wrench -V.A.G 1590- .
- Remove crankshaft-belt pulley ⇒ [page 41](#) .

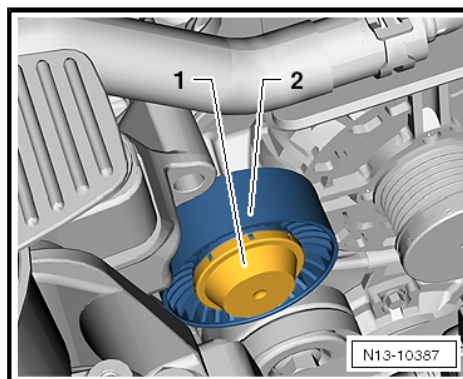

- Slacken all the fixing screws of the timing case -1- carefully remove the timing case.

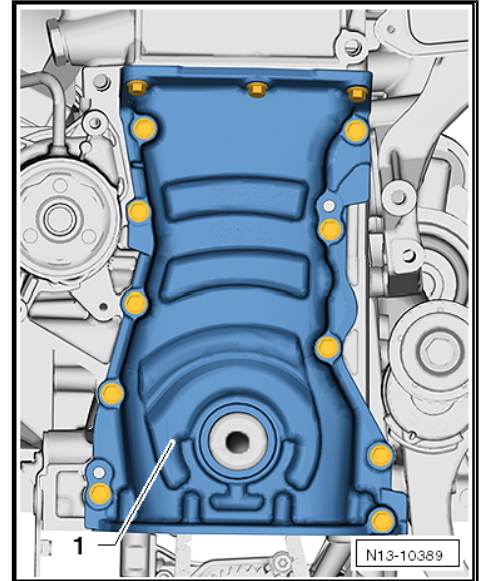

- Release chain tensioner -arrow- for timing chain.
- Mark with a felt-tip pen the direction of rotation of the timing chain.

Protected by copyright. Copying for private or commercial purposes, in part or in whole, is prohibited unless authorised by ŠKODA AUTO A. S. ŠKODA AUTO A. S. does not guarantee or accept responsibility with respect to the correctness of information in this document. Copyright by ŠKODA AUTO A. S.

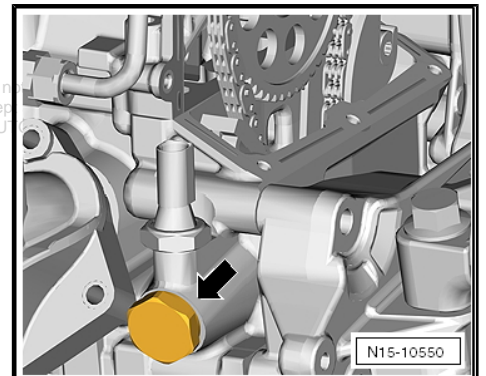

- Hold the camshaft sprocket with the counterholder -T10172- and slacken the fixing screw -1- of the camshaft sprocket.
- Remove the camshaft sprocket together with the fixing screw.
- Remove timing chain downwards.

Install timing chain ⇒ [page 71](#)

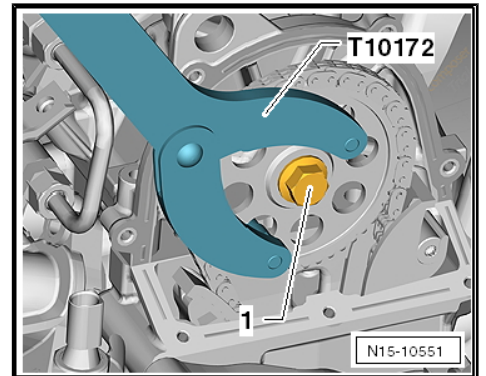

## 1.4.2 Removing and installing the drive chain for oil pump

### Removing

- Pull off the cover -1- from the oil pump.
- Mark with a felt-tip pen the direction of rotation of the drive chain for oil pump.

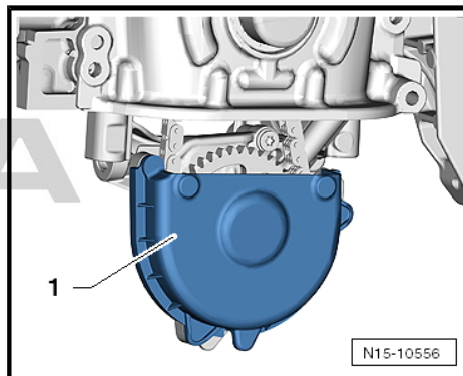

- Unscrew the fixing screws -arrows- of the oil pump.
- Remove the complete oil pump from the drive chain.

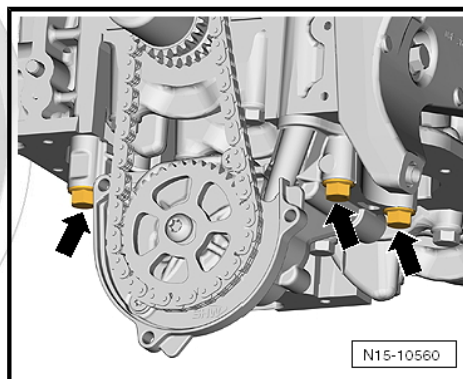

- Remove the drive chain for oil pump -1- from the rear ring gear -2- of the crankshaft gear.

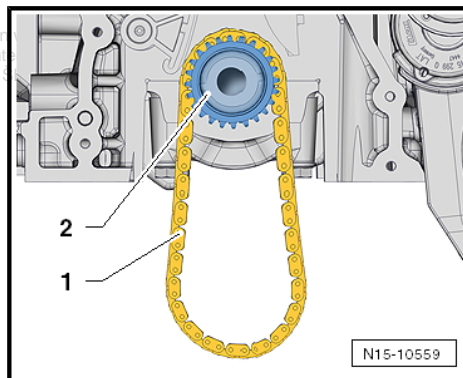

### Install

- Place the drive chain for oil pump -1- on the rear ring gear -2- of the crankshaft gear.

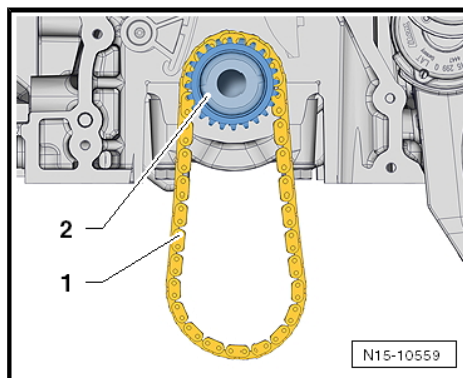

- Hook the oil pump with the chain sprocket into the drive chain and tighten the new screws -arrows- to 14 Nm + torque a further 90° (1/4 turn.).

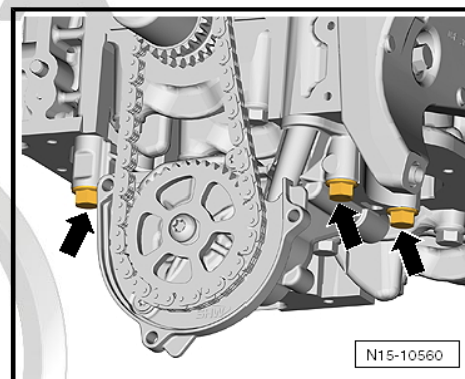

### 1.4.3 Installing timing chain

- Position the timing chain -1- from below at the front ring gear -2- and guide it upwards between the sliding rail and the tensioning rail.
- Secure the timing chain, for example with a screwdriver -3-, against falling down.

Protected by copyright. Copying for private or commercial purposes, in part or in full, without the written permission of ŠKODA AUTO A. S. ŠKODA AUTO A. S. does not guarantee the correctness of information in this document. Copyright © 2010 ŠKODA AUTO A. S.

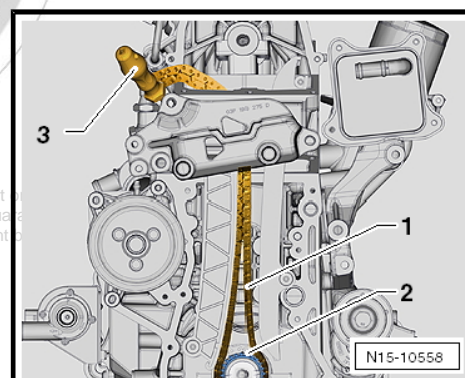

- Place the timing chain -1- onto the chain sprocket -2-.
- The timing chain must rest in the area of the sliding rail -3- and be slightly tensioned.

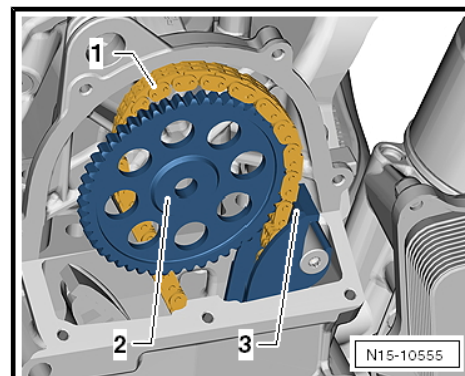

- Hold the camshaft sprocket with the counterholder -T10172- and tighten the fixing screw -1- of the camshaft sprocket to 50 Nm.

**i** Note

*The fixing screw is only turned a further 90° (1/4 turn) after checking the timing at the end of the work procedure.*

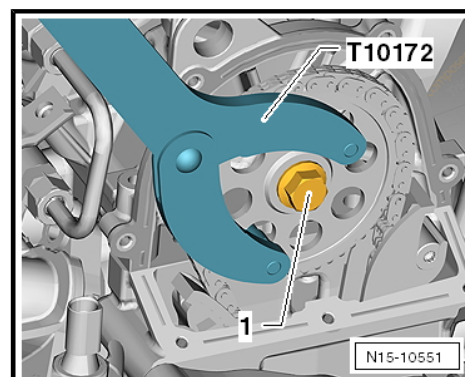



- Tighten chain tensioner -arrow- to 60 Nm.
- Remove the fixing bolt -T10414 - from the camshaft.
- Release the fixing screw -T10340- from the cylinder block.
- Turn the crankshaft in direction of rotation of engine by 2 turns.
- Test timing ⇒ [page 58](#) .

If timing is o.k.:

- Hold the camshaft sprocket with the counterholder -T10172- and torque the fixing screw -1- a further 90° (1/4 turn).
- Install bottom timing case ⇒ [page 35](#) .

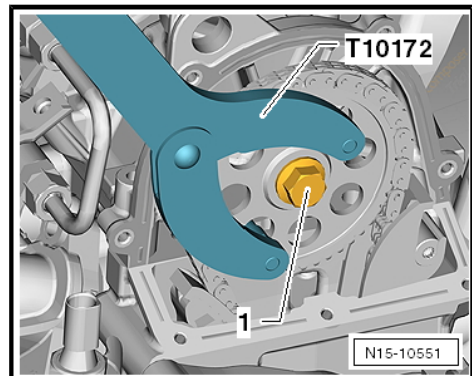
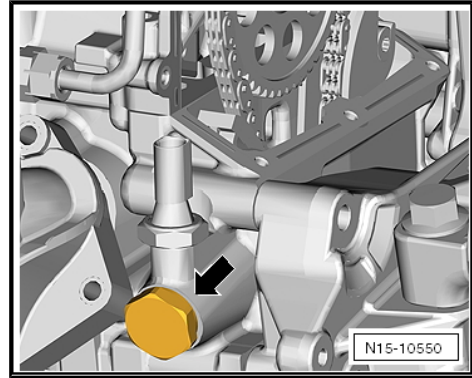

- Fit the cover -1- on the oil pump.
- Installing the oil pan ⇒ [page 93](#) .
- Install crankshaft belt pulley ⇒ [page 41](#) .
- Install the V-ribbed belt ⇒ [page 26](#) .
- Install top timing case ⇒ [page 33](#) .
- Top up coolant ⇒ [page 99](#) .

Further installation occurs in a similar way in reverse order to removal.

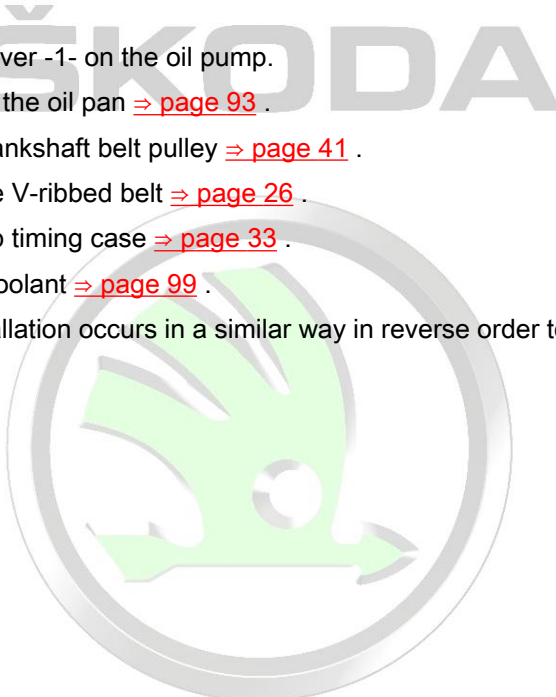
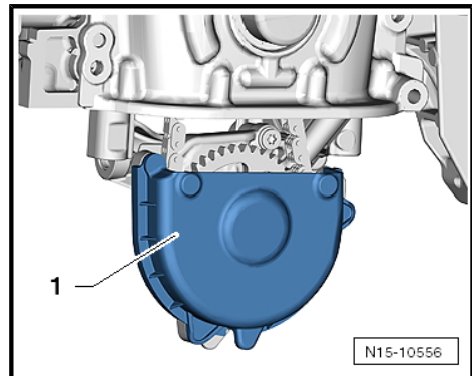



## 2 Cylinder head - part 2

### 2.1 Removing and installing cylinder head cover and camshaft



Note

*The camshaft is located in the cylinder head cover.*

#### Special tools and workshop equipment required

- ◆ Fixing bolts -T10414-
- ◆ Locating screw -T10340-
- ◆ Counterholder -T10172 -
- ◆ Sealant - D 154 103 A1- (cylinder head cover/cylinder head)
- ◆ Sealant - D 189 500 A1- (cylinder head cover/cylinder head)
- ◆ Sealant remover gasket stripper (bearing code GST, bearing article no. R 34402), manufacturer Retech s.r.o.
- ◆ Cleaning and degreasing agent , e.g. -D 000 401 04-
- ◆ Protective goggles and gloves
- ◆ Screw M6x70 (2x) : adapt the screws by sawing off the heads

#### 2.1.1 Remove cylinder head cover

- Disconnect the battery-earth strap with the ignition off ⇒ Electrical System ⇒ Rep. gr. 27 .
- Remove noise insulation ⇒ Body Work ⇒ Rep. gr. 50 .
- Drain coolant ⇒ [page 99](#) .
- Remove top timing case ⇒ [page 33](#) .

#### Vehicles with auxiliary heating.

- Unscrew the screws -1 and 2- of the brackets for the coolant pipes for the auxiliary heating -3-.

Continued for all vehicles

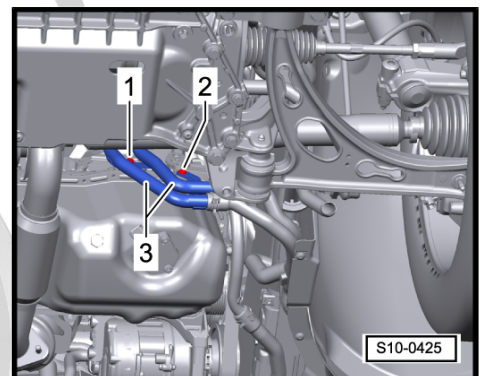



- Release fixing screws -1- and remove bracket for coolant pipe -2-.

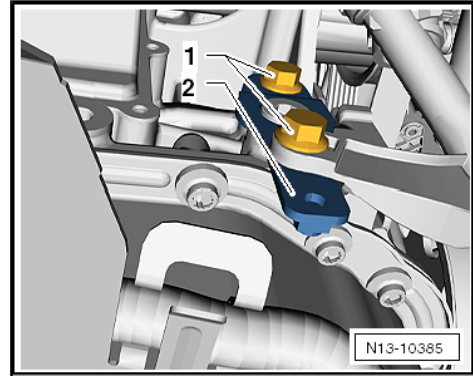

- Release screw plug -arrow- at cylinder block.

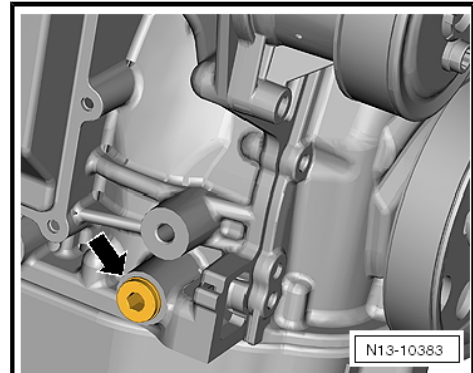

- Turn the fixing screw -T10340- up to the stop in the cylinder block.

**⚠ Caution**

*If the fixing screw -T10340- cannot be screwed in up to the stop, the crankshaft is not in the correct position!  
In this case proceed as described below.*

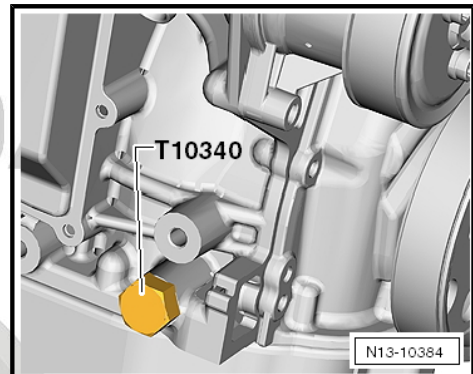

- Unscrew the fixing screw.
- Turn crankshaft 90° (1/4 turn) in direction of rotation of engine.
- Turn the fixing screw -T10340- up to the stop in the cylinder block.
- Tighten fixing screw -T10340- to 30 Nm.
- Turn crankshaft up to the stop in direction of rotation of engine.

The crankshaft is locked in direction of rotation of engine with the fixing screw -T10340- .

- Pull off both coolant hoses -1- from the non-return valve.
- Release the fixing screw -2- and pull the non-return valve out of the cylinder head cover.

Protected by copyright. Copying for private or commercial purposes, in part or in full, is prohibited unless authorised by ŠKODA AUTO A. S. ŠKODA AUTO A. S. does not guarantee the correctness of information in this document. Copyright © 2010 ŠKODA AUTO A. S.

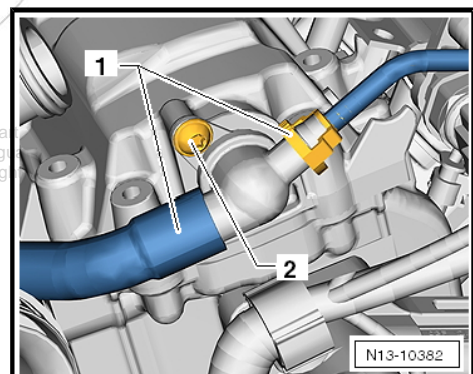



- Insert the fixing bolt -T10414- up to the stop into the cylinder head cover.
- Tighten fixing screw -1- by hand.
- Removing the oil pan => [page 93](#) .

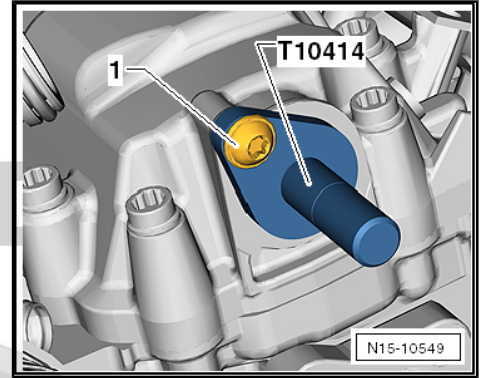

- Pull off the cover -1- from the oil pump.

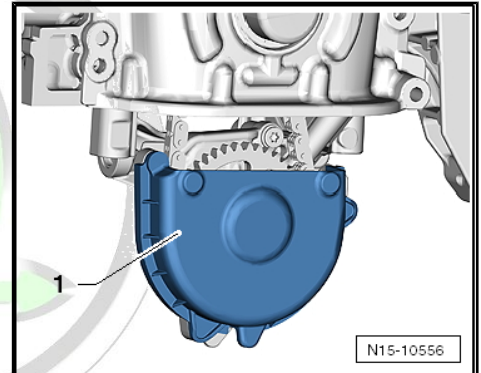

- Release chain tensioner -arrow- for timing chain.

Protected by copyright. Copying for private or commercial purposes without the written permission of ŠKODA AUTO A. S. ŠKODA AUTO A. S. is not permitted. We do not accept any liability with respect to the correctness of information in this document.

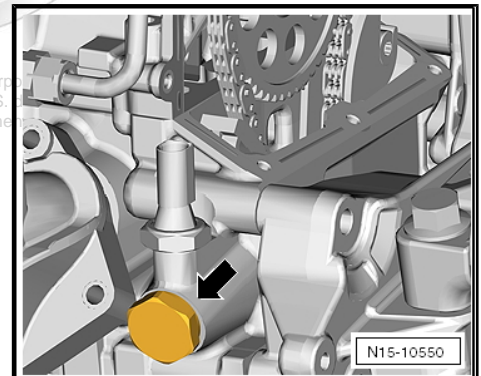

- Hold the camshaft sprocket with the counterholder -T10172- and slacken the fixing screw -1- of the camshaft sprocket.
- Remove the camshaft sprocket together with the fixing screw.

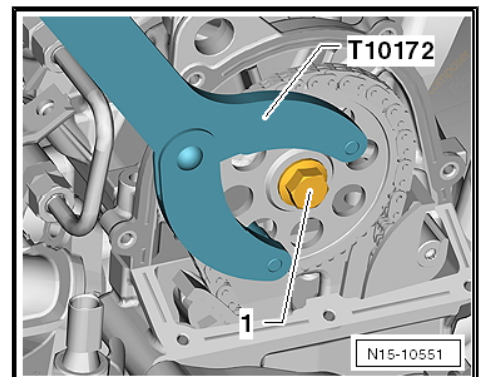



- Place the chain sprocket -1- down on the integrated peg -arrow- in the timing case.



**Note**

*The integrated peg on the inner side of the timing case prevents the chain sprocket from falling down.*

- Detach hose to air filter from cylinder head cover.
- Release screws -1- and remove retaining clip.
- Disconnect plug -2- at charge pressure sender -G31- .
- Release the catches in -direction of arrow- and detach the pressure pipe -3- first of all from the throttle valve control unit -J338 - and then from the exhaust gas turbocharger.
- Fold open the cover and release the fixing screw -4-.
- Disconnect all the spark plug connectors -arrows- using the extractor -T10112 A- from the spark plugs and lay the ignition cables to the rear.
- Remove the high pressure pump ⇒ [page 174](#) .
- Unplug connectors from the fuel injection valves.

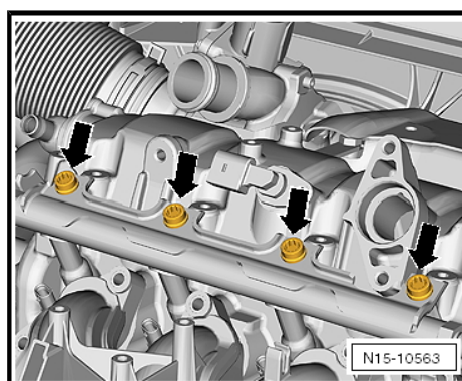
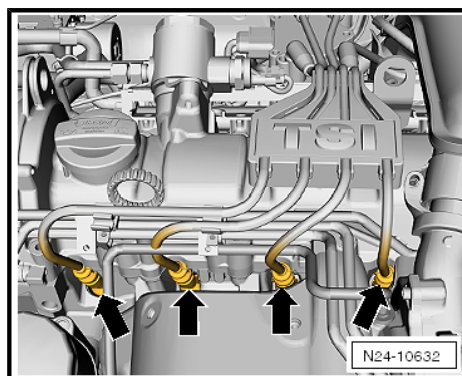
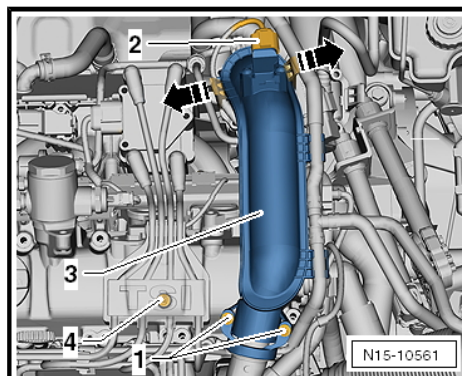
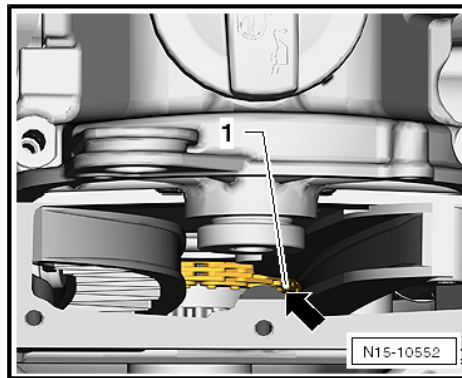

- Release the screws -arrows- and disconnect the fuel distributor from the injection valves.
- Remove exhaust turbocharger ⇒ [page 154](#) .
- Disconnect the plug from the Hall sender -G40- .
- Pull out oil dipstick.
- Slacken the fixing screws of the cylinder head cover crosswise from outside to inside and unscrew.
- Carefully remove the cylinder head cover.



**Note**

*Ensure that no dirt and sealant residues get into the cylinder head.*

Remove and install camshaft ⇒ [page 77](#) .

Install cylinder head cover ⇒ [page 78](#) .

Protected by copyright. Copying for private or commercial purposes, in part or in whole, is not permitted without the written permission of SKODA AUTO A. S. SKODA AUTO A. S. does not guarantee or accept any liability with respect to the correctness of information in this document. Copyright by SKODA AUTO A. S. ©

## 2.1.2 Removing and installing camshaft

### Removing

- Remove fixing bolt -T10414- .
- Place the cylinder head cover on the work bench as shown.
- Release the fixing screws for the bearing frame in the specified order -A- to -J-.
- Remove bearing frame.

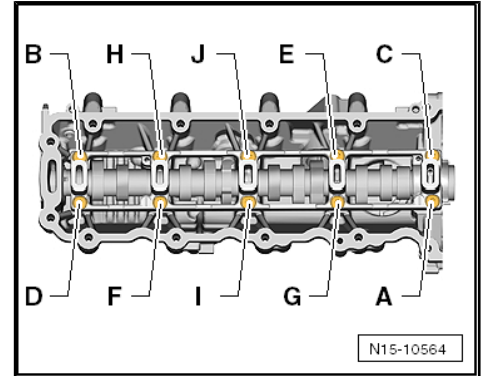

- Lift the camshaft -1- out of the cylinder head cover -2-.

### Install



#### Note

*Before fitting, moisten the camshaft and the camshaft bearings lightly with engine oil.*

- Place the camshaft -1- in the cylinder head cover -2-.
- Insert the fixing bolt -T10414 - into the nuts of the camshaft and tighten the screw by hand.
- Position the bearing frame onto the bearing surfaces of the camshaft.

The bearing frame is put into the correct position by means of the centering pins -arrows-.

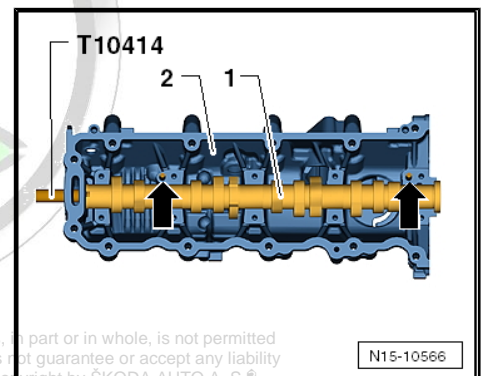
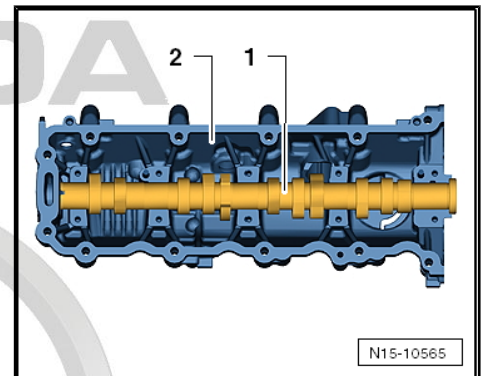

- Tighten the fixing screws to 8 Nm in the specified order -A- to -J-.

Install cylinder head cover ⇒ [page 78](#) .

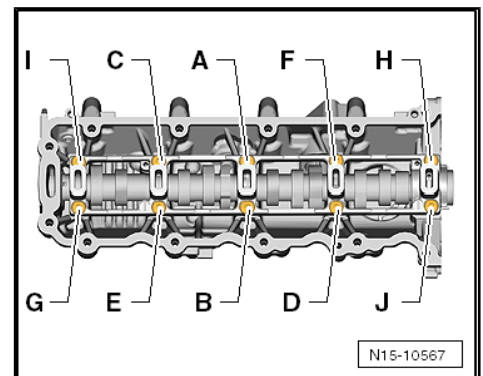

Protected by copyright. Copying for private or commercial purposes, in part or in whole, is not permitted unless authorised by ŠKODA AUTO A. S. ŠKODA AUTO A. S. does not guarantee or accept any liability with respect to the correctness of information in this document. Copyright by ŠKODA AUTO A. S. ©



### 2.1.3 Install cylinder head cover



#### Caution

*Before installing the cylinder head cover, screw in the pin screws (M 6 x 70) at the cylinder head.*

*The pin screws guide the cylinder head cover and prevent the roller rocker arms sliding off from the balancing elements.*

#### Precondition

- The pistons must not be positioned at top dead centre.



#### WARNING

*Wear protective gloves when working with sealant and grease remover!*

- Remove residual sealant from the sealing surfaces at the cylinder head cover and at the cylinder head with chemical sealant remover.
- Degrease the sealing surfaces.
- Screw in two pin screws (M 6 x 70) -1- into the cylinder head before fitting on the cylinder head cover.



#### Caution

*The cylinder head cover is sealed with 2 different sealants!*



#### Note

*The sealant must not be applied too thickly, as otherwise excess sealant may penetrate into the oil bores and possibly cause engine damage.*

- Apply sealant -D 189 500 A1 - on the sealing surface -1-.  
The sealant bead must be 2...3 mm thick and must run past the area around the bolt holes on the inside.
- Apply a thin layer of sealant -D 154 103 A1 - evenly to the gridded sealing surfaces -2-.
- Check if the roller rocker arms rest on the balancing elements.
- Carefully fit the cylinder head cover over the pin screws and position the dowel pins onto the cylinder head.

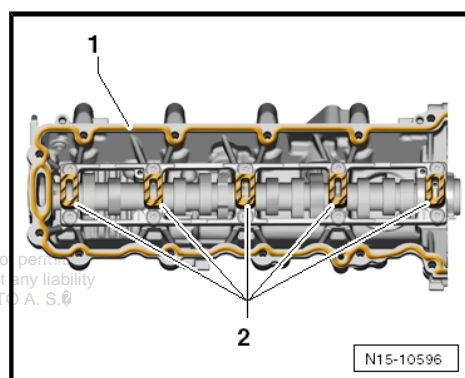
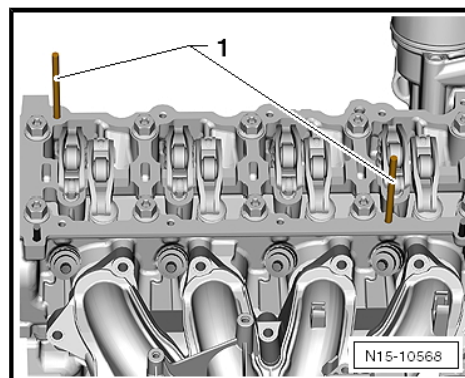



- Tighten the new fixing screws of the cylinder head cover in the specified order -A- to -J-.

Tightening torque: 8 Nm + torque a further 90° (1/4 turn).



**Caution**

*The sealant for the cylinder head cover must absolutely be removed in the area of the -arrows-.*

*In order to avoid leakage, the sealant for the cylinder head cover and the sealant for the timing case must not mix.*

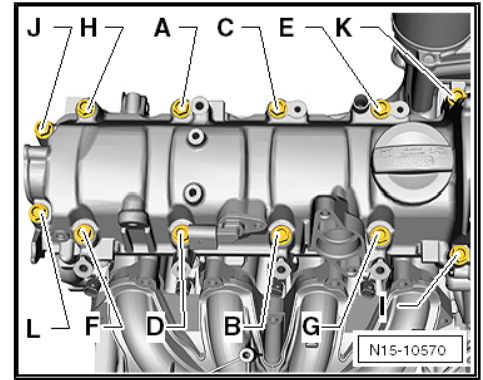

- Remove excess sealant in the area of the -arrows-.
- Turn crankshaft up to the stop in direction of rotation of engine.

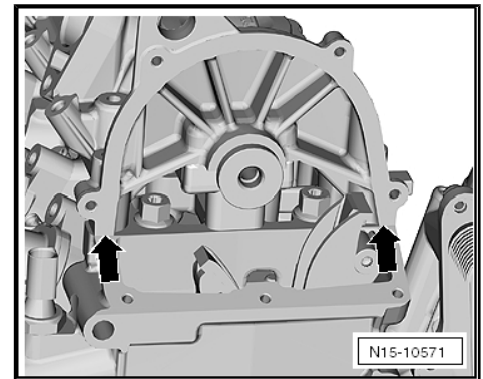

- Lift up the timing chain with the assembly device -T10118- .

ŠKODA

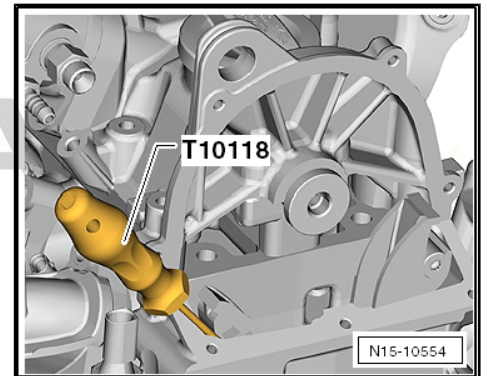

- Check the correct position of the timing chain -1- on the crankshaft gear from below.

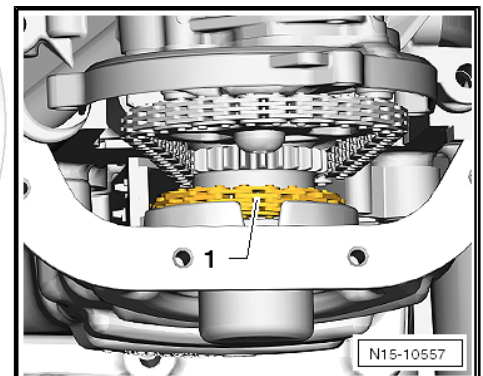

Protected by copyright. Copying for private or commercial purposes, in part or in whole, is not permitted unless authorised by ŠKODA AUTO A. S. ŠKODA AUTO A. S. does not guarantee or accept any liability with respect to the correctness of information in this document. Copyright by ŠKODA AUTO A. S. ©



- Place the timing chain -1- onto the chain sprocket -2-.

The timing chain must rest in the area of the sliding rail -3- and be slightly tensioned.

ŠKODA

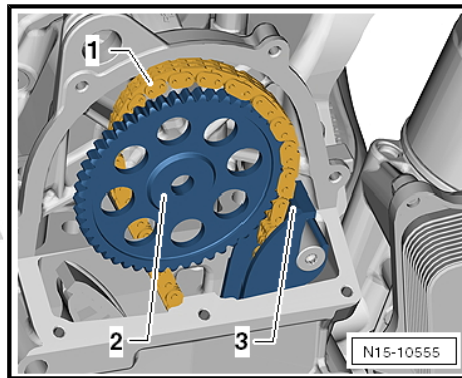

- Hold the camshaft sprocket with the counterholder -T10172- and tighten the fixing screw -1- of the camshaft sprocket to 50 Nm.



**Note**

The fixing screw is only turned a further 90° (1/4 turn) after checking the timing at the end of the work procedure.

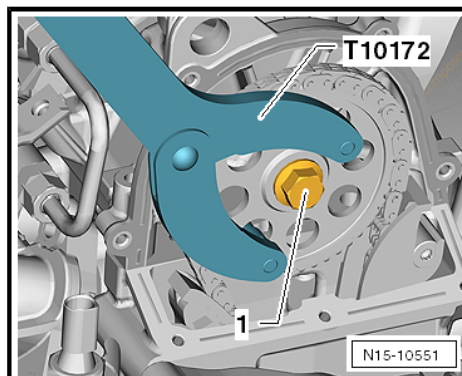
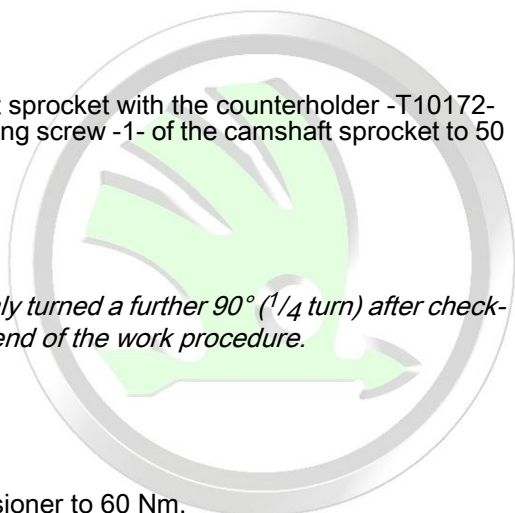

- Tighten chain tensioner to 60 Nm.
- Remove the fixing bolt -T10414- from the camshaft.
- Release the fixing screw -T10340- from the cylinder block.
- Turn the crankshaft in direction of rotation of engine by 2 turns.
- Turn the fixing screw -T10340- up to the stop in the cylinder block.
- Turn crankshaft up to the stop in direction of rotation of engine.

The timing is O.K., if the fixing bolt -T10414- can be inserted in the camshaft.

If the timing is not O.K.

- Repeat the setting of the timing ⇒ [page 60](#) .

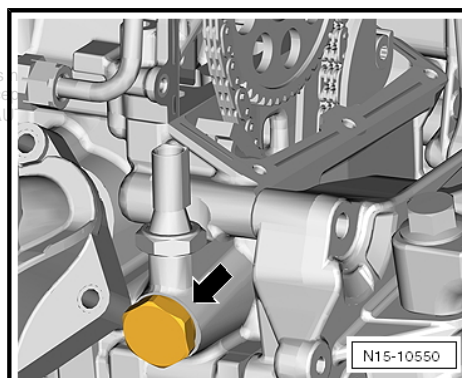

- Hold the camshaft sprocket with the counterholder -T10172- and torque the fixing screw -1- a further 90° (1/4 turn).
- Remove fixing bolt -T10414- and fixing screw -T10340- .
- Install top timing case ⇒ [page 33](#) .
- Install exhaust turbocharger ⇒ [page 154](#) .
- Installing the oil pan ⇒ [page 93](#) .
- Install crankshaft belt pulley ⇒ [page 41](#) .
- Install high pressure pump ⇒ [page 174](#) .
- Install fuel lines ⇒ [page 173](#) .

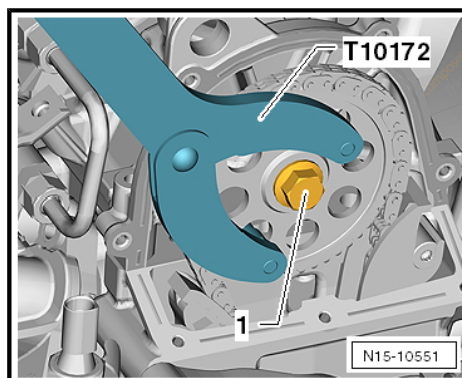

Further installation occurs in a similar way in reverse order to removal.

## 2.2 Removing and installing the cylinder head

### Special tools and workshop equipment required

- ◆ Supporting device -T30099-
- ◆ Surface -T30099/1-
- ◆ Support -T10358-
- ◆ Sealant remover gasket stripper (bearing code GST, bearing article no. R 34402), manufacturer Retech s.r.o.
- ◆ Cleaning and degreasing agent , e.g. -D 000 401 04-
- ◆ Protective goggles and gloves

### Removing

#### Requirements

- Engine temperature should not exceed 35 °C, because the cylinder head could be twisted when slackening the screws.
- The pistons must not be in TDC

Observe safety measures ⇒ [page 3](#) .

Observe rules for cleanliness ⇒ [page 5](#) .



#### WARNING

*Release pressure in the high pressure area of the fuel system  
⇒ [page 4](#) .*

- Drain the coolant from the engine cooling system  
⇒ [page 99](#) .
- Remove coolant regulator housing from cylinder head.
- Remove top timing case ⇒ [page 33](#) .
- Remove bottom timing case ⇒ [page 35](#) .
- Remove exhaust turbocharger ⇒ [page 154](#) .
- Removing the intake manifold ⇒ [page 169](#) .
- Fit supporting device -T30099- .
- Unscrew the fixing screw for the gearbox and screw down the bracket -T10358- as shown. (The figure shows the version with the 1.4 ltr./90 kW TSI Engine; the hanger is identical).
- Support the engine via the spindle in its installed position and slightly pre-tension.

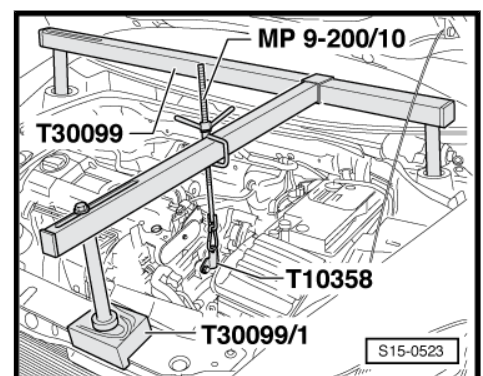

Protected by copyright. Copying for private or commercial purposes, in part or in whole, is not permitted unless authorised by ŠKODA AUTO A. S. ŠKODA AUTO A. S. does not guarantee or accept any liability with respect to the correctness of information in this document. Copyright by ŠKODA AUTO A. S. ©



- Disconnect the fuel feed line -1- and the cable to the activated charcoal filter -2-. To do so press the release buttons.



**WARNING**

*The fuel feed line is pressurized! Wear safety goggles and safety gloves, in order to avoid injuries and skin contact. Place cleaning cloths around the connection point before detaching hose connections. Reduce pressure by carefully removing the hose.*

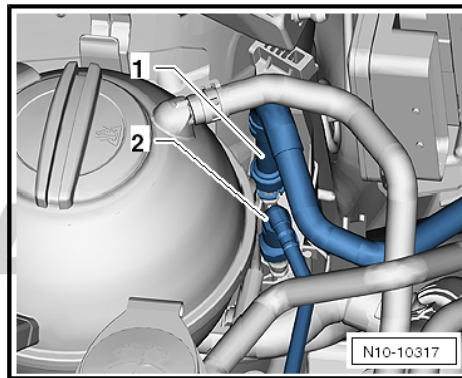

- Release the fixing screws -2- and pull the activated charcoal filter upwards.

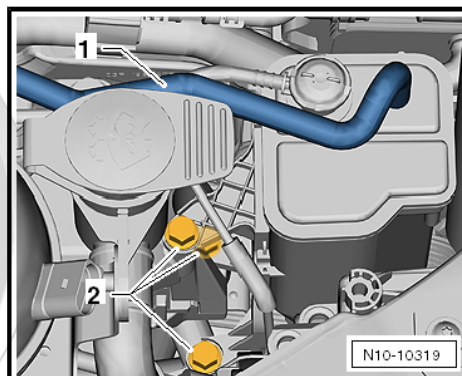
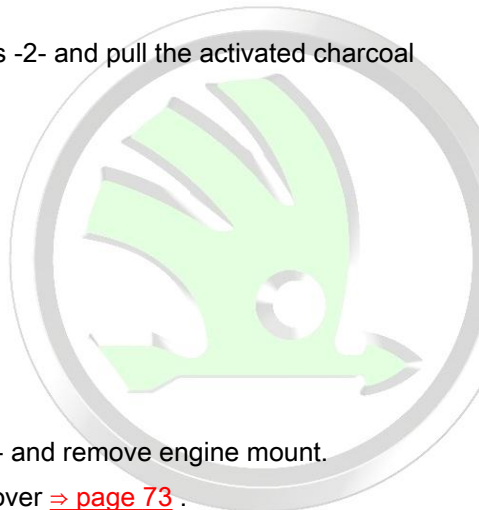

- Unscrew screws -arrows- and remove engine mount.
- Remove cylinder head cover => [page 73](#).
- Remove the tensioning rail and the sliding rail of the timing chain.
- Remove the roller rocker arms together with the balancing elements and lay aside on a clean surface.
- Ensure that the roller rocker arms and the balancing elements are not mixed up.

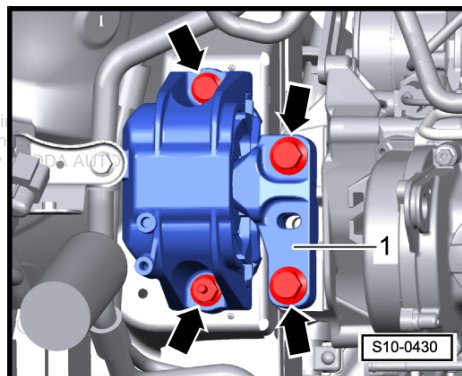

- Release the cylinder head bolts in the specified sequence and remove.
- Carefully remove the cylinder head.

**Install**

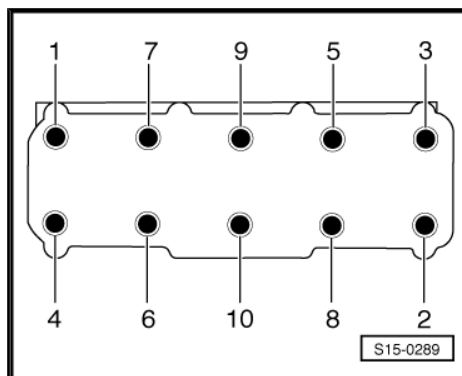



Tightening torque of non-return valve -arrow-: 7 Nm.

### Precondition

- The pistons must not be in TDC



### Note

- ◆ Remove the new cylinder head gasket from its wrapping immediately before fitting.
  - ◆ Treat the new gasket with the utmost care. Any damage will result in leaks.
  - ◆ There must be no oil or coolant in the blind holes of the cylinder head bolts in the cylinder block.
- Stuff clean cloth into the cylinders to avoid any dirt getting in between cylinder wall and piston.

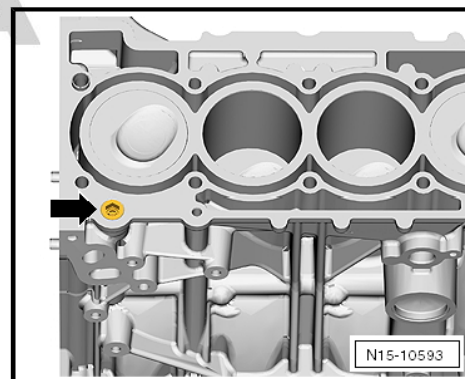

### WARNING

**Wear protective gloves when working with sealant and grease remover!**

Protected by copyright. Copying for private or commercial purposes, in part or in whole, is not permitted unless authorised by ŠKODA AUTO A. S. ŠKODA AUTO A. S. does not guarantee or accept any liability with respect to the correctness of information in this document. Copyright by ŠKODA AUTO A. S. ©

- Make sure that when cleaning the cylinder head and cylinder block no foreign bodies can get into the cylinder or into the oil and coolant galleries.
- Carefully remove old sealant residue from the cylinder head and cylinder block using a chemical sealant remover.
- Position piston of cylinder 1 to top dead centre and slightly turn the crankshaft anticlockwise again.
- Position the new cylinder heads. The legend (part number) must be legible.
- Insert the cylinder head. Pay attention to the centering pins in the cylinder block.
- Insert new cylinder head bolts and tighten by hand.
- Tighten cylinder head bolts in the tightening order shown as follows:
  - ◆ Tighten all bolts initially to 40 Nm.
  - ◆ Then, torque all bolts further to 90° (1/4 turn) with a rigid wrench.
  - ◆ Finally, once again turn all bolts through a further 90° (1/4 turn).
- Insert the balancing elements in the cylinder head and position the relevant roller rocker arm on the valve stem ends or balancing elements.
- Install cylinder head cover ⇒ [page 73](#) .
- Setting the timing ⇒ [page 60](#) .

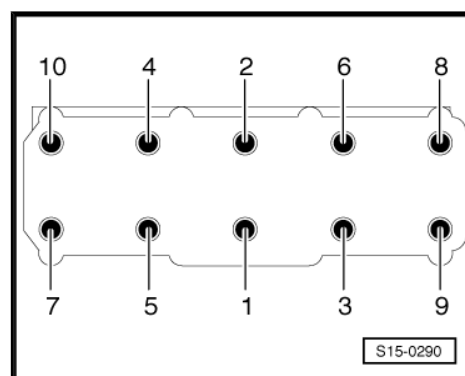

Further installation occurs in a similar way in reverse order to removal.

- Top up and bleed cooling system ⇒ [page 99](#) .

## 2.3 Testing the compression

Special tools and workshop equipment required



- ◆ Spark plug wrench -3122 B-
- ◆ Compression tester -V.A.G 1763-
- ◆ Extractor -T10112 A-

**Test condition**

- Engine oil temperature must be at least 30°C.

**Work procedure**

- Pull out the spark plug connector -arrows- with the extractor -T10112 A- .
- Unscrew the spark plugs with the spark plug wrench -3122 B- .
- Open lid of fuse carrier in the engine compartment and unplug the fuse for fuel pump control unit ⇒ Current flow diagrams, Electrical fault finding and Fitting locations.
- Check compression pressure using the compression tester -V.A.G 1763- .

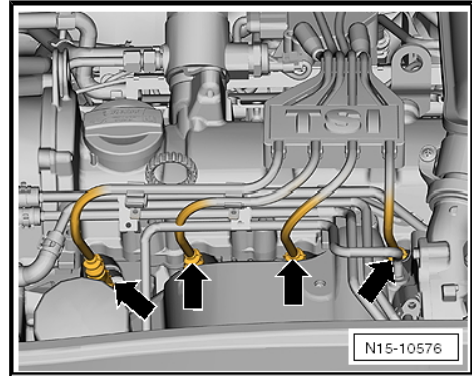

**Note**

Use of tester ⇒ *Operating Instructions* .

- Operate starter until the tester no longer indicates a pressure rise.

**Compression readings**

New engine	Wear limit	Difference between cylinders
1...1.5 MPa (10...15 bar)	0,7 MPa (7 bar)	0.3 MPa (3 bar)

If the specified values are not reached, test the combustion chamber for tightness ⇒ [page 84](#) .

The further assembly is carried out in reverse order to disassembly. Pay attention to the following:

- Delete the contents of the fault memory for the engine control unit at the end of the work as error messages were stored due to disconnecting the plugs ⇒ Vehicle diagnostic, testing and information system VAS 5051.

**2.4 Testinf the combustion chamber for tightness**

**Special tools and workshop equipment required**

- ◆ Pressure hose -MP1-210 (VW 653/3)- (replace gasket ring with a spark plug gasket ring)
- ◆ Extractor -T10112 A-
- ◆ Spark plug wrench -3122 B-

**Test sequence**

- Unscrew the spark plugs with the spark plug wrench -3122 B- .
- Position piston of the relevant cylinder to top dead centre (TDC).
- Screw the pressure hose MP.1-210 into the spark plug thread.
- Connect pressure hose to compressed air.



- With the assistance of a second mechanic, lock the screw at the crankshaft on „top dead centre position“ in order to avoid the displacement of the piston after pressure build-up.
- Build up a pressure of approx. 0.3 MPa (3 bar) in the combustion chamber.
- Determine how the pressure escapes:
  - 1 - Via the inlet valve(s) - the pressure enters the throttle valve.
  - 2 - Via the outlet valve(s) - the pressure enters the exhaust system.
  - 3 - Via the piston rings - the pressure enters the cylinder block.

# ŠKODA



Protected by copyright. Copying for private or commercial purposes, in part or in whole, is not permitted unless authorised by ŠKODA AUTO A. S. ŠKODA AUTO A. S. does not guarantee or accept any liability with respect to the correctness of information in this document. Copyright by ŠKODA AUTO A. S. ©



### 3 Valve gear

#### 3.1 Valve gear - Summary of components

1 - 50 Nm + torque a further 90° (1/4 turn)

- replace

2 - Camshaft sprocket

- take note of the position when installing the timing chain

3 - 10 Nm

4 - Hall sender -G40-

- with O-ring
- replace the O-ring if it is damaged

5 - Cylinder head cover

- removing and installing ⇒ [page 73](#)

6 - Non-return valve

7 - 10 Nm

8 - O-ring

- replace if damaged
- before fitting moisten lightly with engine oil

9 - Camshaft

- removing and installing ⇒ [page 73](#)
- Inspecting axial play ⇒ [page 87](#)
- moisten with oil before installing (also axial bearing collar)

10 - Valve collet

11 - Valve spring retainer

12 - Valve stem seal

- replace

13 - Valve spring

- with the cylinder head removed, remove and install with blank holder -3362-
- (with cylinder head installed) ⇒ [page 88](#)

14 - Valve guide

- check ⇒ [page 87](#)

15 - Cylinder head

- removing and installing ⇒ [page 81](#)

16 - Valves

- do not rework, only grinding in is permissible
- Valve dimensions ⇒ [page 87](#)

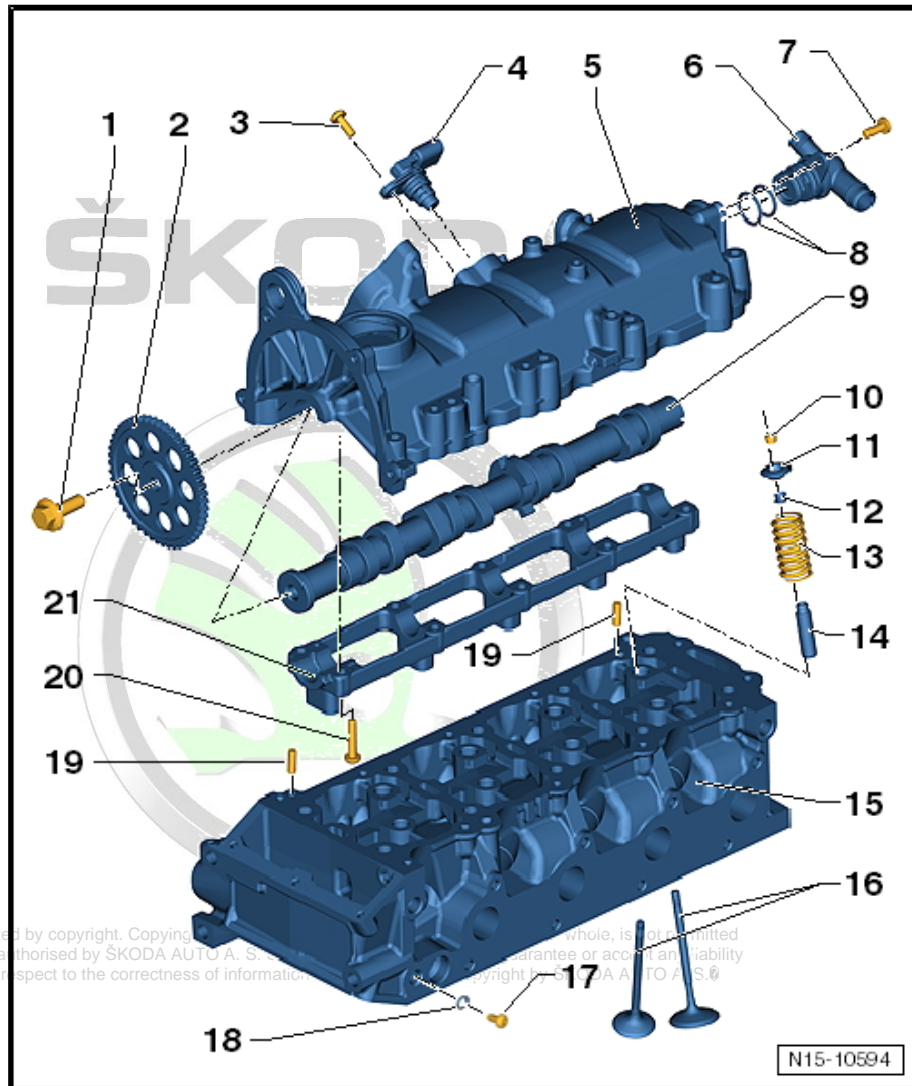

17 - 15 Nm

18 - Gasket

- replace

19 - Dowel pins

20 - 8 Nm

- observe the order of tightening up
- removing and installing => [page 73](#)

21 - Bearing frame

- for camshaft
- removing and installing => [page 73](#)

### 3.2 inspect camshaft, axial play

Special tools and workshop equipment required

- ◆ Universal dial gauge holder -MP 3-447 (VW 387)-
- ◆ Dial gauge

Perform measurement with the cylinder head cover installed.

#### Checking the axial play of the camshaft

- Wear limit: 0.4 mm

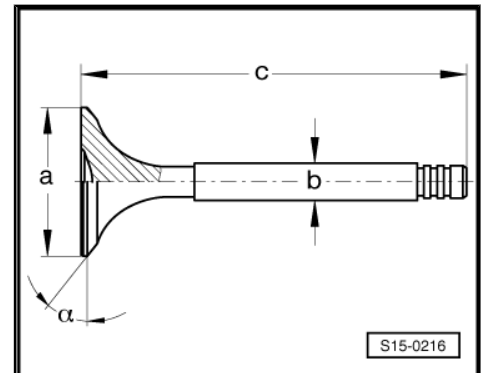
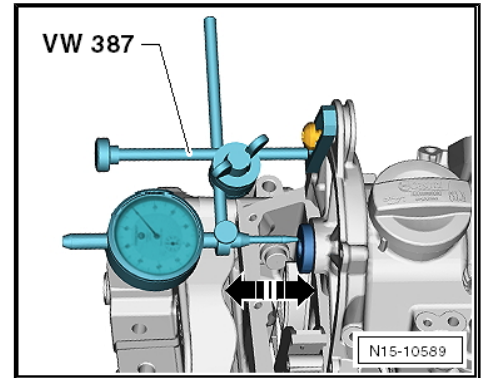

#### Valve dimensions



Note

Valves must not be reworked. Only grinding in is permissible.

Dimension		Inlet valve	Exhaust valve
∅ a	mm	35,5	30,0
∅ b	mm	5,98	5,96
c	mm	98,67	98,36
α	∠°	44° 50'	44° 50'

### 3.3 Inspect valve guides

Special tools and workshop equipment required

- ◆ Universal dial gauge holder -MP 3-447 (VW 387)-
- ◆ Dial gauge



## Work procedure



### Note

If the valve is replaced when carrying out repair work, use a new valve for the measurement.

- Insert valve into guide. The end of valve stem must be flush with guide. Because of the different stem diameters only use inlet valve in inlet guide or outlet valve in outlet guide.
- Determine valve rock.
- Wear limit: 0,8 mm



### Note

If the wear limit is exceeded, repeat measurement with new valves.

If the valve rock is exceeded:

- Replace the cylinder head.

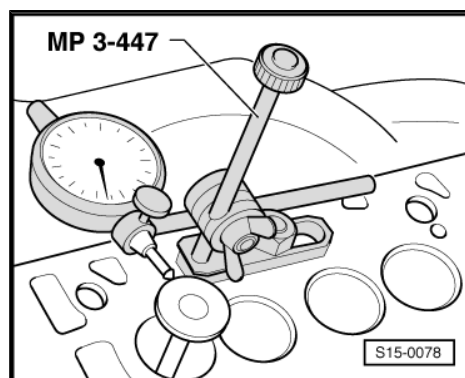

## 3.4 Replacing valve stem seals

### Special tools and workshop equipment required

- ◆ Spark plug wrench -3122 B-
- ◆ Valve lever -MP 1-211 (VW 541/1A/5) -
- ◆ Pressure hose -MP 1-210 (VW 653/3)-
- ◆ Assembly device -MP 1-213 (2036)-
- ◆ Valve supporting plate -MP 1-218-
- ◆ Valve stem seal insertion tool - MP 1-233 (3365)-
- ◆ Valve stem seal extractor -MP 1-230 (3364)-

### Removing



### Note

With cylinder head removed, use valve lever -MP 1-211- , assembly device for valves -MP 1-213- and valve supporting plate -MP 1-218- .

With cylinder head installed:

- Remove cylinder head cover ⇒ [page 73](#) .
- Remove roller rocker arm and place on a clean surface. Make sure that you do not mix up the roller rocker arms. Copyright by ŠKODA AUTO A. S. ©
- Unscrew the spark plugs with spark plug wrench -3122 B- .
- Put the piston of the relevant cylinder at „bottom dead centre“.

- Screw the assembly device -MP 1-213 (2036)- onto the cylinder head.
- Screw the pressure hose -MP 1-210 (VW 653/3)- in the spark plug thread.
- Connect pressure hose to compressed air [min. 0.6 MPa (6 bar) overpressure] and remove the valve spring with valve lever -MP 1-211 (VW 541/1A/5) - and pressure plate -VW 541/7- .
- Pull off valve stem seal with extractor for valve stem seal -MP 1-230 (3364)- .

#### Install

- Insert the supplied plastic bushings on the relevant valve stem. This will prevent any damage to the new valve stem seals.
- Insert the new valve stem seal -1- into the insertion tool for valve stem seal -MP 1-233 (3365)- .
- Oil the sealing lip of the valve stem seal and carefully slide over the valve -2- onto the valve guide.
- Installing camshaft housing ⇒ [page 73](#) .

Further installation occurs in a similar way in reverse order to removal.

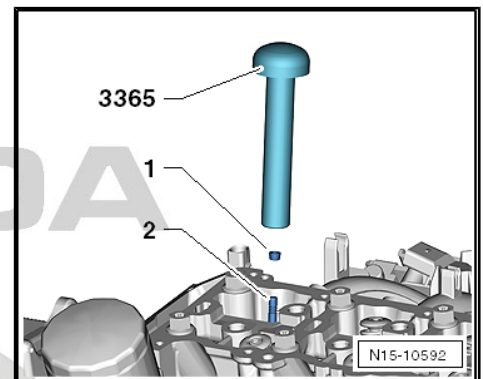
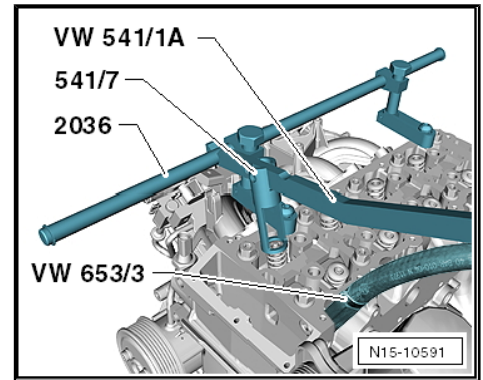



## 17 – Lubrication

### 1 Lubrication system



#### Note

- ◆ *The oil level must not be above the max. marking - risk of damage to catalytic converter!*
- ◆ *If considerable quantities of metal swarf or abrasion is found when carrying out engine repairs, this can be subject to damage to the crankshaft and conrod bearings. In order to avoid consequential damage, after the repair perform the following tasks:*
  - Carefully clean the oil galleries.
  - Replace oil spray jets.
  - Replace engine oil cooler.
  - Replace oil filter.

Inspecting oil pressure ⇒ [page 96](#) .

Check the engine oil, amount of oil and oil specification ⇒ **Maintenance ; Booklet Yeti**

#### 1.1 Summary of components

# ŠKODA



Protected by copyright. Copying for private or commercial purposes, in part or in whole, is not permitted unless authorised by ŠKODA AUTO A. S. ŠKODA AUTO A. S. does not guarantee or accept any liability with respect to the correctness of information in this document. Copyright by ŠKODA AUTO A. S. ©

**1 - Screw cap**

- Replace seal if damaged

**2 - Oil feed line**

- to exhaust gas turbo-charger

**3 - Dipstick**

- Oil level must not exceed the max. marking!

**4 - Bracket for top auxiliary units**

- removing and installing ⇒ [page 27](#)

**5 - Gasket**

- replace if damaged

**6 - Guide bushing**

**7 - Oil filter, 20 Nm**



**Note**

*When removing, make sure that the oil does not penetrate into the generator! Therefore, cover the generator with a clean cloth!*

- with gasket rings
- with non-return valve
- slacken and tighten with oil filter wrench -3417-
- Keep to change intervals ⇒ Maintenance ; Booklet Yeti

**8 - 25 Nm**

**9 - Gasket**

- replace if damaged

**10 - 8 Nm + torque a further 90° (1/4 turn)**

- replace

**11 - Engine oil cooler**

- removing and installing ⇒ [page 95](#)

**12 - 8 Nm**

**13 - Top timing case**

- removing and installing ⇒ [page 33](#)



**Caution**

*Pay attention to tightening process!*

**14 - 25 Nm**

**15 - Bottom timing case**

- removing and installing ⇒ [page 35](#)

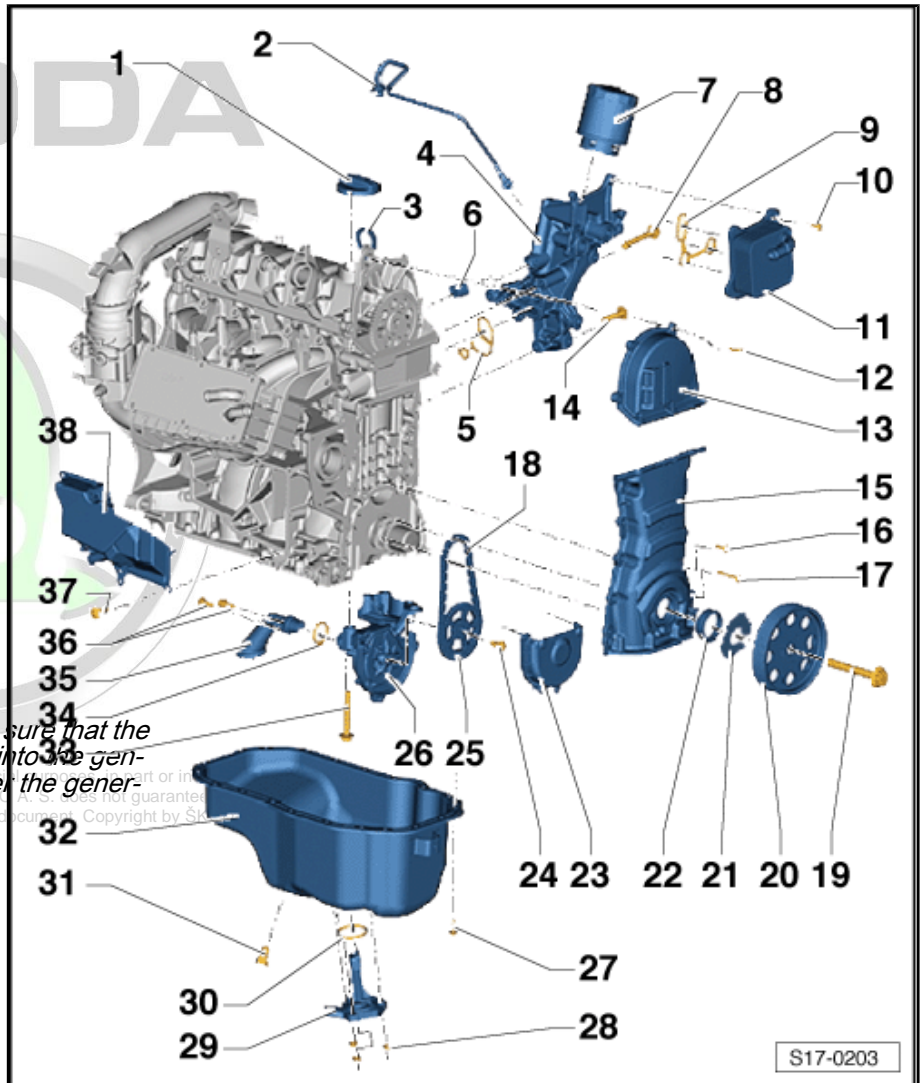

S17-0203

**16 - 5 Nm + torque a further 30°**

- Screw: M6x20

**17 - 5 Nm + torque a further 30°**

- Screw: M6x40

**18 - Chain**

- removing and installing ⇒ [page 66](#)
- for oil pump
- mark running direction (installed position) before removing

**19 - 150 Nm + torque a further 180° (1/2 turn)**

- replace
- The clamping surface of the fixing screw must be free of grease and oil.
- insert oiled (thread)
- Secure belt pulley with counterholder -3415- to prevent it from turning

**20 - Belt pulley**

- Pay attention to tightening process ⇒ [page 41](#)
- Clamping surfaces must be free of oil and grease.
- Secure belt pulley with counterholder -T30004 (3415)- with bolts -T30004/2 (3415/2)- to prevent it from turning

**21 - Diamond coated washer**

- replace

**22 - Sealing ring**

- replace
- removing and installing ⇒ [page 40](#)

**23 - Bottom cover**

Copyright. Copying for private or commercial purposes, in part or in whole, is not permitted unless authorised by ŠKODA AUTO A. S. ŠKODA AUTO A. S. does not guarantee or accept any liability with respect to the correctness of information in this document. Copyright by ŠKODA AUTO A. S.

**24 - 20 Nm + torque a further 90° (1/4 turn)**
**25 - Sprocket**

- for oil pump drive
- Clamping surfaces must be free of oil and grease.
- Lock chain sprocket with counterholder -T10172-

**26 - Oil pump**

- removing and installing ⇒ [page 95](#)
- must be replaced completely

**27 - 13 Nm**

- replace
- slacken and tighten only the bolts at the gearbox side with socket insert -T10058-

**28 - 10 Nm**
**29 - Oil level and oil temperature sender -G266 -**

- replace if damaged
- check ⇒ Current flow diagrams, Electrical fault finding and Fitting locations

**30 - Sealing ring**

- replace if damaged

**31 - Oil drain plug, 30 Nm**

- with captive seal
- replace

**32 - Oil pan**

- removing and installing ⇒ [page 93](#)



33 - 14 Nm + torque a further 90° (1/4 turn)

34 - Sealing ring

- replace

35 - Suction line

36 - 8 Nm

37 - 8 Nm

38 - Oil separator

mount using locking agent -D 176 501 A1-

## 1.2 Removing and installing oil pan

### Special tools and workshop equipment required

- ◆ Socket insert -T10058-
- ◆ Sealant remover gasket stripper (bearing code GST, bearing article no. R 34402), manufacturer Retech s.r.o.
- ◆ Cleaning and degreasing agent , e.g. -D 000 401 04-
- ◆ Protective goggles and gloves
- ◆ Silicone sealant -D 176 600 A1-
- ◆ Catch pan , e.g. -VAS 6208-

### Removing

- Remove noise insulation ⇒ Body Work ⇒ Rep. gr. 50 .
- Drain engine oil ⇒ Maintenance ; Booklet Yeti .
- Remove exhaust pipe Pos. 9 ⇒ [page 188](#) .
- Disconnect plug at oil level and oil temperature sender - G266- .

Protected by copyright. Copying for private or commercial purposes, in part or in whole, is not permitted unless authorized in writing by ŠKODA AUTO A. S. ŠKODA AUTO A. S. does not guarantee or accept any liability with respect to the correctness of information in this document. Copyright by ŠKODA AUTO A. S. ©



- Release screw -1- from bracket for coolant pipe.
- Unscrew both fixing screws -3- and remove the bottom cover plate.
- Loosen bolts for oil pan crosswise and release.
- Remove oil pan, if necessary release by applying slight blows with a rubber-headed hammer.



**WARNING**

*Wear protective gloves when working with sealant and grease remover!*

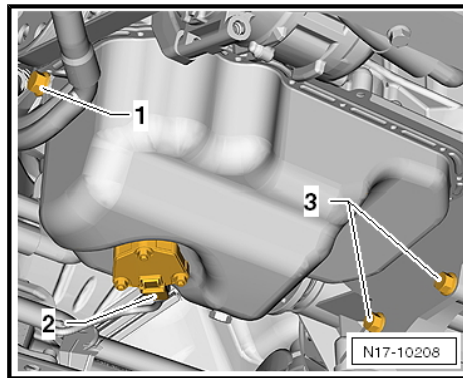

- Remove the remaining sealant on the cylinder block and on the oil pan with chemical sealant remover.
- Degrease the sealing surfaces.

**Install**



**Note**

- ◆ *Replace M6 oil pan bolts.*
- ◆ *Pay attention to the use by date on sealant.*
- ◆ *The oil pan must be installed within 5 minutes after applying the silicone sealant.*

- Cut off nozzle tube at the front marking (Ø of nozzle approx. 3 mm).
- Apply silicone sealant to the clean sealing surface of the oil pan, as shown in the illustration. The sealant bead must be:
  - ◆ be 2...3 mm thick
  - ◆ run past the area around the bolt holes on the inside -arrows-

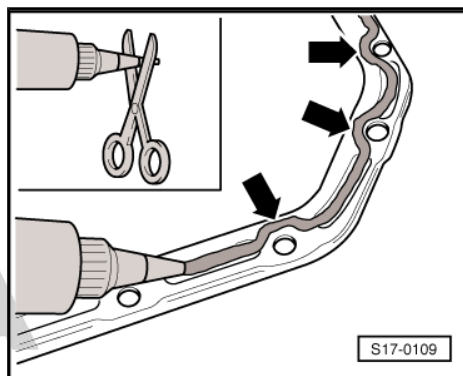

**Note**

*The sealant bead must not be thicker otherwise excess sealant may get into the oil pan and block the strainer in the oil suction pipe.*

- Fit oil pan immediately and lightly tighten all oil pan screws.
- Tighten the screws of the oil pan to 13 Nm.
- Tighten the fixing screws of the cover plate at the gearbox to 40 Nm.

Further installation occurs in a similar way in reverse order to removal.



**Note**

*After installing the oil pan, allow the sealant to dry for about 30 minutes. Only then may engine oil be filled in.*

## 1.3 Removing and installing oil pump

### Special tools and workshop equipment required

- ◆ Catch pan , e.g. -VAS 6208-
- Removing the oil pan ⇒ [page 93](#) .
- Pull off the cover -1- from the oil pump.

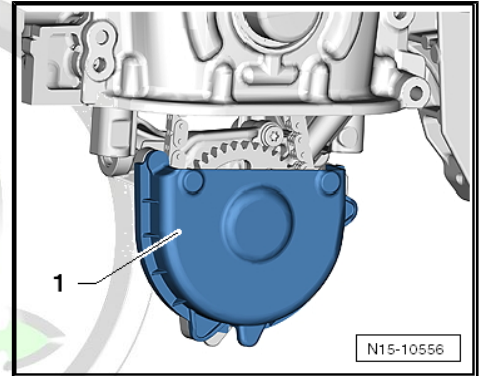

- Unscrew the fixing screws -arrows- of the oil pump.
- Remove the complete oil pump from the drive chain.

### Install

Protected by copyright. Copying for private or commercial purposes without the written permission of SKODA AUTO A. S. is prohibited. SKODA AUTO A. S. does not accept any liability with respect to the correctness of information in this document. Copy

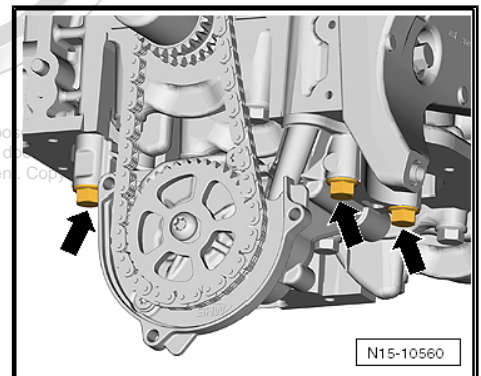

- Hook the oil pump with the chain sprocket into the drive chain and tighten the new screws -arrows- to 14 Nm + torque a further 90° (1/4 turn.).

Tightening torque of the suction line: 8 Nm

- Installing the oil pan ⇒ [page 93](#) .

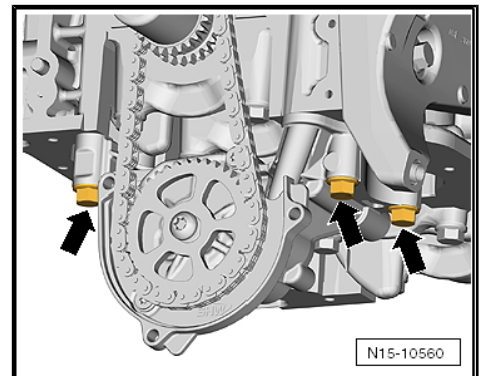

## 1.4 Removing and installing engine oil cooler

### Special tools and workshop equipment required

- ◆ Catch pan , e.g. -VAS 6208-
- ◆ Hose binding claw

### Removing

- Drain the coolant from the engine cooling system ⇒ [page 99](#) .



- Open the spring strap clamp with the hose binding claw and detach the coolant hose -1-.
- Release the four fixing screws from the engine oil cooler and remove the engine oil cooler.

### Install



#### Note

*Replace gasket if damaged.*

- Position the engine oil cooler -2- at the bracket and tighten the fixing screws crosswise to 8 Nm + torque a further 90° (1/4 turn).
- Place the coolant hose -1- onto the oil cooler fitting and attach it with the spring strap clip.
- Top up and bleed cooling system ⇒ [page 99](#) .
- Inspect coolant level in the expansion reservoir, top up with coolant if necessary.



#### Note

*If the engine oil cooler was replaced, the coolant must be changed.*

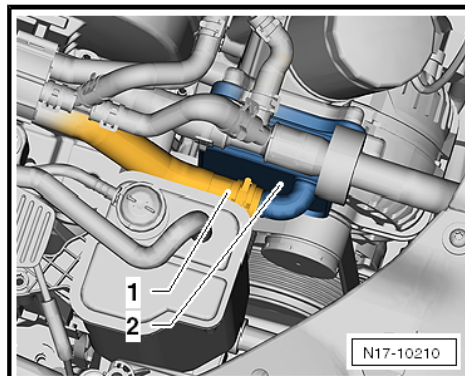
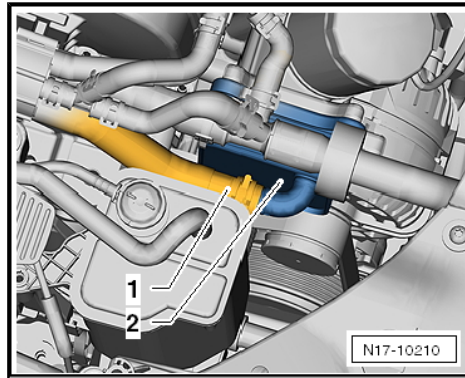

## 1.5 Testing oil pressure and oil pressure switch

### Special tools and workshop equipment required

- ◆ Oil pressure tester , e.g. -V.A.G 1342 -
- ◆ Voltage tester , e. g. -V.A.G 1527 B-
- ◆ Measuring tool set , e.g. -V.A.G 1594 C-
- ◆ Vehicle diagnosis, measurement and information system - VAS 505X-

### Conditions

- Engine oil level o.k., test ⇒ Maintenance ; Booklet Yeti .
- Coolant temperature at least 80°C (radiator fan must have run at least once).



#### Note

*Functional test and repair of the visual and acoustic oil pressure display ⇒ Current flow diagrams, Electrical fault finding and Fitting locations, ⇒ Vehicle diagnostic, testing and information system VAS 5051.*

# ŠKODA

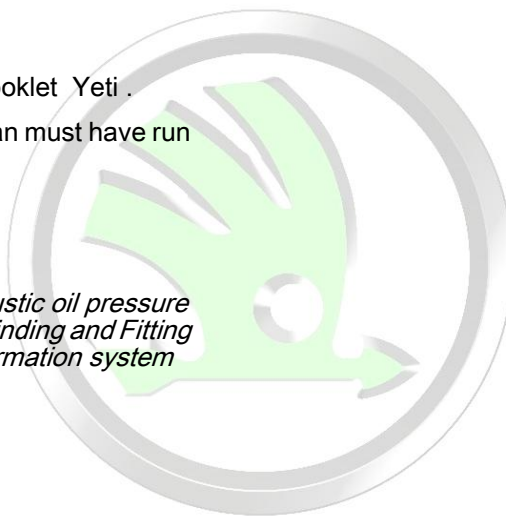



### Test sequence

- Disconnect plug -1- and remove the oil pressure switch -2-.

# ŠKODA

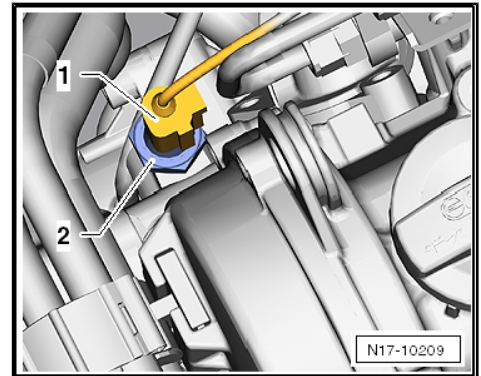

- Screw oil pressure switch into the test equipment.
- Screw tester in the cylinder head instead of the oil pressure switch.
- Connect brown cable of tester to earth (-).
- Connect voltage tester to battery positive and to oil pressure switch.

- The LED must not light up.

If the LED lights up:

- Replace oil pressure switch -F1- .

If the LED does not light up:

- Start engine and increase engine speed.

- The LED must light up at an oil overpressure of 0.03...0.07 MPa (0.3...0.7 bar), if not replace oil pressure switch.

- Increase engine speed further.

- At 2000 rpm and an oil temperature of 80°C the oil overpressure should be at least 0.2 MPa (2.0 bar).

At a higher engine speed the oil overpressure must not be greater than 0.7 MPa (7 bar).

Tightening torque of the oil pressure switch: 20 Nm

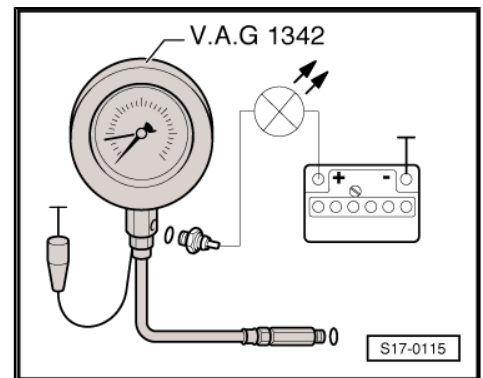

Protected by copyright. Copying for private or commercial purposes, in part or in whole, is not permitted without the written permission of ŠKODA AUTO A. S. ŠKODA AUTO A. S. does not guarantee or accept any liability with respect to the correctness of information in this document. Copyright by ŠKODA AUTO A. S. ©



## 19 – Cooling

### 1 Cooling system



#### WARNING

*Hot steam may escape when the coolant expansion reservoir is opened. Wear safety goggles and safety clothing, in order to avoid eye injuries and scalding. Cover the cap with a cloth and open carefully.*



#### Note

- ◆ *When the engine is warm the cooling system is under pressure. If necessary reduce pressure before repairs.*
- ◆ *The hose connections are secured with spring-type clips. In case of repair only assign the spring strap clamps via the ⇒ Electronic catalogue of original parts .*
- ◆ *Use pliers for spring strap clamps to fit the spring strap clips.*
- ◆ *Always replace seals and gasket rings.*
- ◆ *When installing fit the coolant hoses free of stress, without them touching any other components (pay attention to the marking on the coolant connection).*
- ◆ *The arrows which are on the coolant pipes and the coolant hose ends must stand opposite to each other.*

#### 1.1 Connection diagram for coolant hoses



#### Note

- ◆ *This engine is fitted with a radiator combination of engine and low temperature radiators for charge air system.*
- ◆ *Engine and low temperature radiators are arranged as one component part.*

- 1 - Expansion reservoir**
- 2 - Coolant recirculation pump -V50-**
  - removing and installing  
⇒ [page 105](#)
- 3 - Coolant pump**
  - removing and installing  
⇒ [page 104](#)
- 4 - Charge air cooler**
  - in the intake manifold  
⇒ [page 159](#)
- 5 - Heat exchanger of heating system**
- 6 - Coolant regulator housing**
- 7 - Non-return valve**
  - in the coolant hose, not visible from the outside
- 8 - Throttle valve**
  - in the coolant hose, not visible from the outside
- 9 - Radiator**
  - removing and installing  
⇒ [page 108](#)
- 10 - Exhaust gas turbocharger**
  - removing and installing  
⇒ [page 154](#)
- 11 - Low temperature radiator for charge air system**
  - Engine and low temperature radiators are arranged as one component part
- 12 - Cylinder head and cylinder block**
  - fill with fresh coolant after replacing
- 13 - Engine oil cooler**
- 14 - Non-return valve**
  - in the coolant hose, not visible from the outside
- 15 - Auxiliary heating**
  - only for vehicles with special equipment

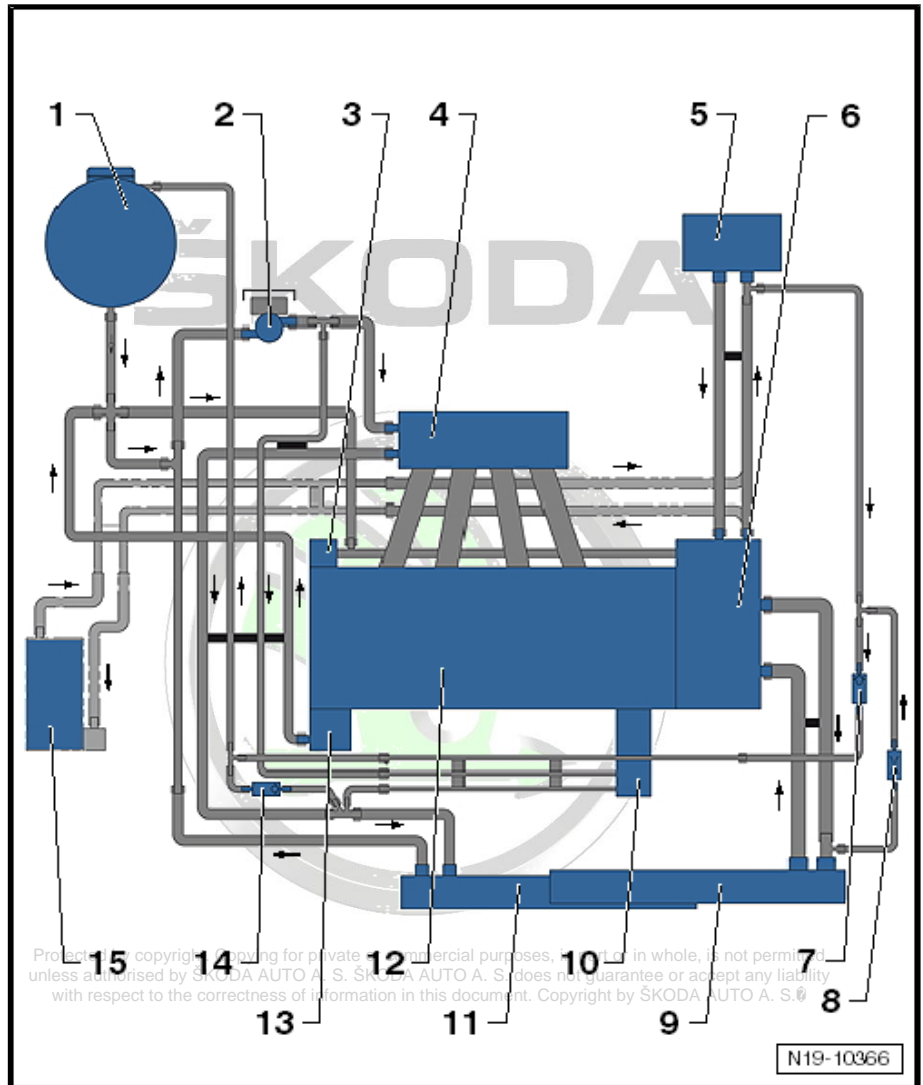

## 1.2 Draining and filling up coolant

### Special tools and workshop equipment required

- ◆ Catch pan , e.g. - VAS 6208-
- ◆ Pliers for spring strap clamps
- ◆ Refractometer -T10007-



## Draining



### Note

- ◆ *Collect drained coolant in a clean container for reuse or proper disposal.*
- ◆ *Observe the disposal instructions.*



### WARNING

*Hot steam may escape when the coolant expansion reservoir is opened. Wear safety goggles and safety clothing, in order to avoid eye injuries and scalding. Cover the cap with a cloth and open carefully.*

- Open compensation bottle.
- Remove noise insulation ⇒ Body Work ⇒ Rep. gr. 50 .
- Place a catch pan - VAS 6208- under the radiator.



### Note

- ◆ *Depending on the components which must be removed ⇒ [page 98](#) , the coolant from the engine cooling system, from the charge air cooling system or from both cooling systems must be drained.*
- ◆ *If the coolant must be replaced, it should be drained from both cooling systems.*

Protected by copyright. Copying for private or commercial purposes, in part or in whole, is not permitted unless authorised by ŠKODA AUTO A. S. ŠKODA AUTO A. S. does not guarantee or accept any liability with respect to the correctness of information in this document. Copyright by ŠKODA AUTO A. S. ©

## Drain the coolant from the engine cooling system

- Disconnect plug -1- from coolant temperature sender at radiator outlet -G83- .
- Open spring strap clamp -arrow- and pull off the coolant hose from the bottom radiator connection.



### Note

*Observe all the disposal instructions!*

## Drain the coolant from the charge air cooling system

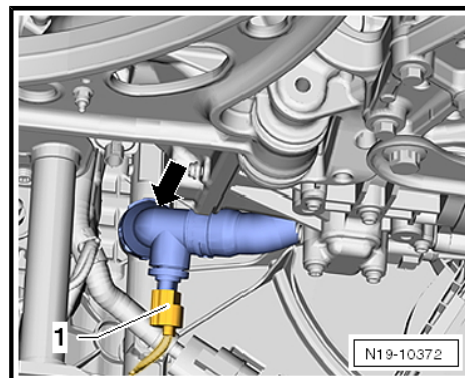

- Separate the coolant hose (quick coupling) -arrow- on the bottom connection fitting of the additional water cooler for charge air system.

 **Note**

*Observe all the disposal instructions!*

**Top up and bleed cooling system.**

Select the appropriate coolant additive from the ⇒ Electronic Catalogue of Original Parts or from the list of allowed coolant additives ⇒ Maintenance ; Booklet Yeti .

- In a clean reservoir mix water and coolant additive in the correct mixing ratio ⇒ Maintenance ; Booklet Yeti .
- Reposition the removed coolant hose onto the relevant support and connect the coolant temperature sender at radiator outlet -G83 - .
- Install the noise insulation ⇒ Body Work ⇒ Rep. gr. 50 .
- Switch off the air-conditioning system and the heating.

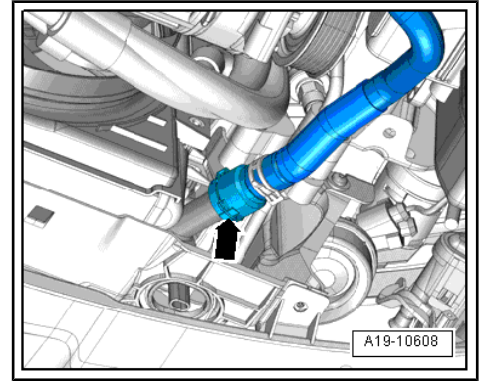

**Caution**

*In order to secure the refrigerating capacity of the charge air cooling system, the following work steps must absolutely be observed.*

# ŠKODA





- Fill up the coolant slowly up to the top marking of the criss-crossed field (max.) on the expansion reservoir.
- Seal expansion reservoir.

**Vehicles without auxiliary heating.**

- Start the engine and maintain the engine speed for about 3 minutes at approx. 2000 r.p.m.
- Run engine until radiator fan -V7- starts.

**Vehicles with auxiliary heating.**



**Caution**

*The auxiliary heating must only be switched on, if the refrigerant circuit is filled up -as described below-.*

- Connect vehicle diagnosis, measurement and information system -VAS 5051- .
- Start the engine and maintain the engine revolutions for about 3 minutes at about 2000 r.p.m.
- On the display press consecutively the buttons for „Vehicle self-diagnosis“, „18 - Auxiliary heating system“ and „03 - Actuator diagnosis“.
- Press the right arrow on the display so often until the coolant shut-off valve of heating system - N279- is shown.
- Perform self-diagnosis of the coolant shut-off valve of heating system -N279- and maintain the engine speed at approx. 2000 rpm for about 1 minute.

**For all vehicles**



**WARNING**

*Hot steam may escape when the compensation bottle is opened. Wear safety goggles and safety clothing, in order to avoid eye injuries and scalding. Cover the cap with a cloth and open carefully.*

- Check the level of coolant when the expansion reservoir is closed and if necessary top up with missing coolant when the engine has cooled down.
- When engine is at operating temperature the coolant level must be at the max. marking, when engine is cold between the min. and the max. markings.

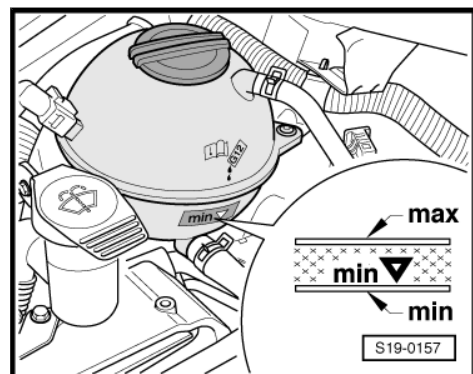
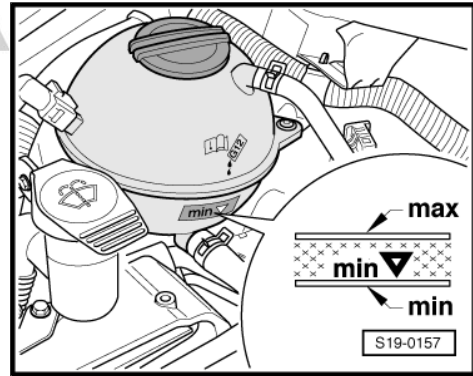



## 2 Parts of cooling system engine side

### 2.1 Coolant regulator - Summary of components

- 1 - Cylinder head
- 2 - O-ring  
 replace
- 3 - Coolant pipe
- 4 - O-ring  
 replace
- 5 - Retaining clip for coolant pipe
- 6 - 11 Nm
- 7 - Coolant regulator housing
- 8 - Gasket  
 replace
- 9 - Coolant temperature sender -G62-  
 before removing, reduce pressure in cooling system if necessary
- 10 - 10 Nm
- 11 - O-ring  
 replace

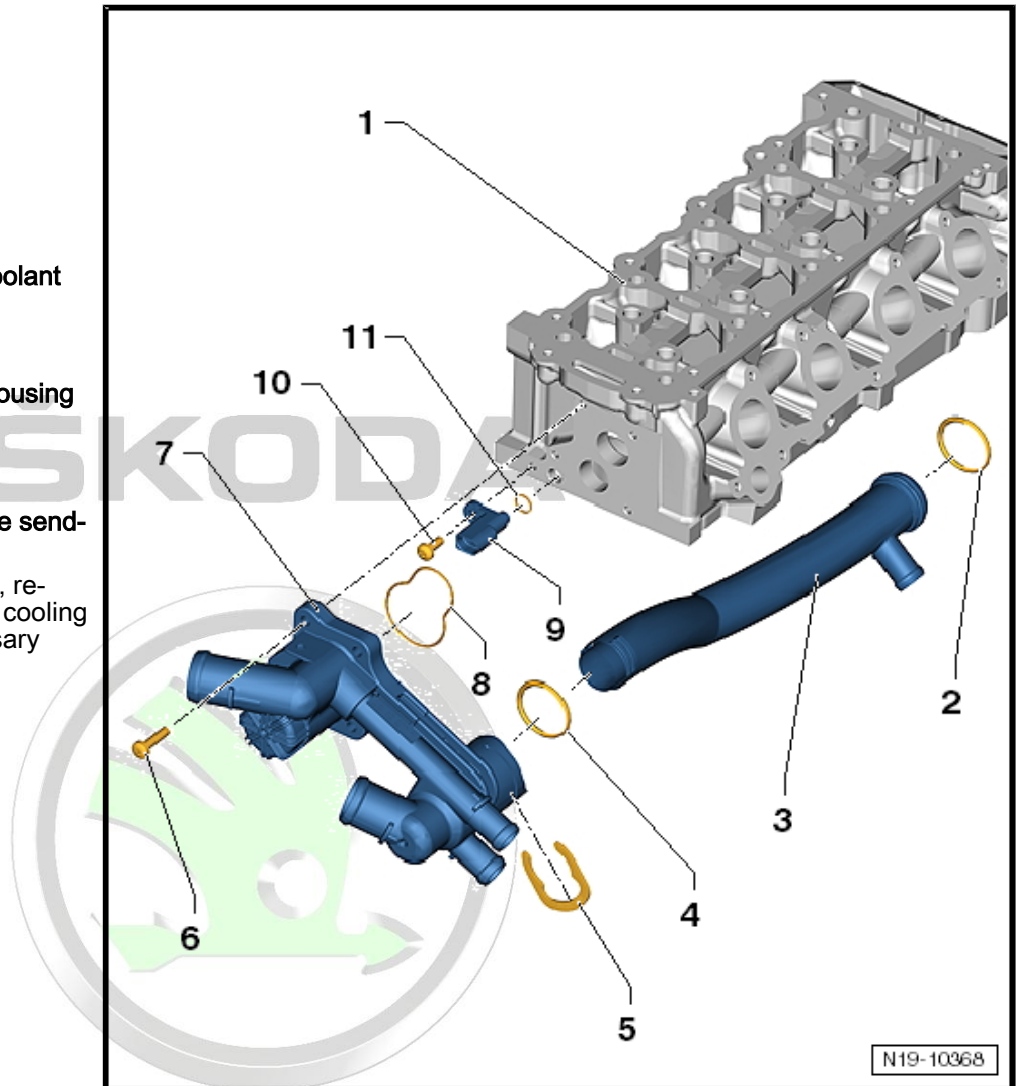

Protected by copyright. Copying for private or commercial purposes, in part or in whole, is not permitted unless authorised by ŠKODA AUTO A. S. ŠKODA AUTO A. S. does not guarantee or accept any liability by ŠKODA AUTO A. S.

### 2.2 Removing and installing belt pulley for coolant pump

#### Special tools and workshop equipment required

- ◆ Wrench for the water pump and power-assisted steering -MP 1-308 (V.A.G 1590) -



### Modify water pump wrench -MP 1-308-

- Because of modified fixing screws for the belt pulley of the coolant pump, these three curvatures must be filed open.

-a- at least 1 mm

#### Removing

- Remove V-ribbed belt => [page 26](#) .

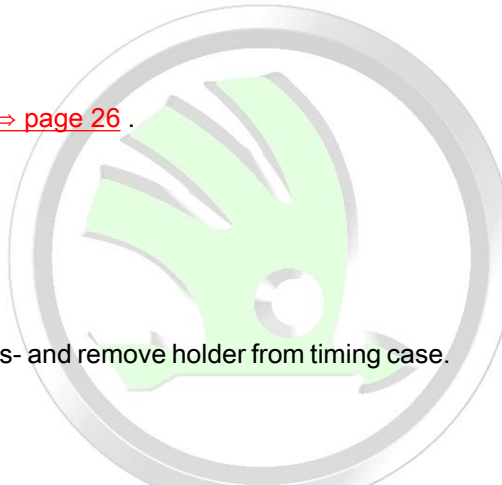

- Release screws -arrows- and remove holder from timing case.



#### Note

*The bracket at the timing case only serves as transport security of the engine before the first installation and must not be refitted.*

Protected by copyright. Copying for private or commercial purposes, in part or in whole, is prohibited without the written permission of ŠKODA AUTO A. S. ŠKODA AUTO A. S. does not guarantee the accuracy of the information in this document. Copyright by ŠKODA AUTO A. S.

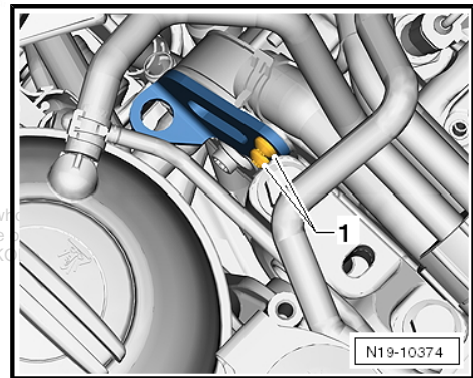
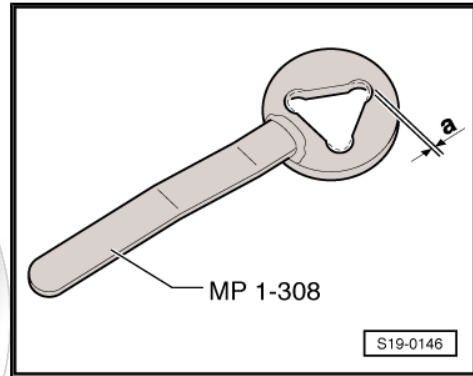

- Release the screws for the belt pulley for coolant pump, to do so counterhold with wrench for the water pump and power-assisted steering -V.A.G 1590 - .

#### Install

Installation is performed in the reverse order, pay attention to the following points:

- ◆ Tightening torque: 20 Nm

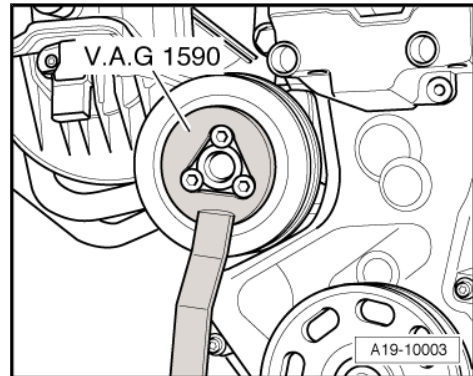

## 2.3 Removing and installing coolant pump

### Special tools and workshop equipment required

- ◆ Catch pan , e.g. -VAS 6208-

#### Removing



#### Note

- ◆ *The integrated gasket of the coolant pump must not be separated from the coolant pump.*
- ◆ *If damage and leak present, replace coolant pump with gasket completely.*
- Drain the coolant from the engine cooling system => [page 99](#) .
- Remove belt pulley for control pump => [page 103](#) .

- Disconnect the vacuum line -1- of the solenoid valve for coolant circuit -N492- from the coolant pump.
- Release screws -arrows- and remove coolant pump.

#### Install

Installation is performed in the reverse order, pay attention to the following points:

- ◆ Tightening torque: 9 Nm
- Install belt pulley for coolant pump ⇒ [page 103](#) .
- Top up and bleed cooling system ⇒ [page 99](#) .

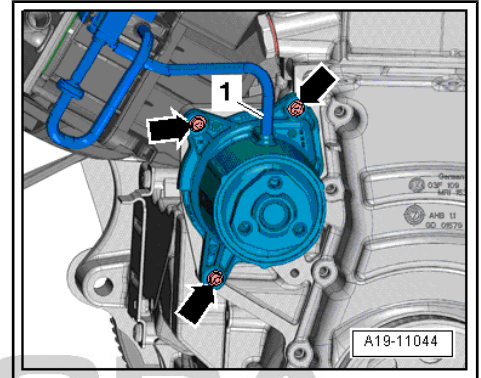

## 2.4 Removing and installing coolant recirculation pump -V50-

#### Special tools and workshop equipment required

- ◆ Hose clamps up to  $\varnothing$  25 mm -MP7-602 (3094) -
- ◆ Pliers for spring strap clamps
- ◆ Catch pan , e.g. -VAS 6208-

#### Removing

- Remove noise insulation ⇒ Body Work ⇒ Rep. gr. 50 .
- Unplug connector -1-.
- Release screw -3- and remove coolant recirculation pump -V50- from bracket.
- Place a catch pan -VAS 6208- under the engine.
- Pinch off coolant hoses -2- with hose clamps -MP7-601- and detach the hoses from the coolant recirculation pump -V50- .

#### Install

- ◆ Tightening torque: 8 Nm.

Installation is performed in the reverse order, pay attention to the following points:

- Inspect coolant level, if necessary top up cooling system and bleed ⇒ [page 99](#) .

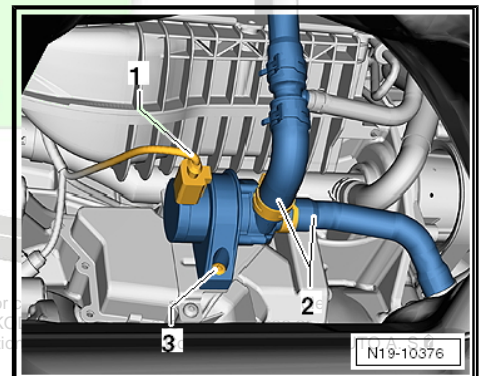



### 3 Radiator and radiator fan

#### 3.1 Parts of cooling system on the side next to the body - Summary of components



**Note**

- ◆ This engine is fitted with a radiator combination of engine and low temperature radiators for charge air system.
- ◆ Engine and low temperature radiators are arranged as one component part.

**1 - Radiator with low temperature radiator for charge air system**

- removing and installing ⇒ [page 108](#)
- after replacing fill entire system with fresh coolant

**2 - Coolant hose**

- to exhaust gas turbo-charger

**3 - Coolant hose**

- to low temperature radiator for charge air system

**4 - Coolant hose**

- to exhaust gas turbo-charger

**5 - Coolant hose**

- to charge-air cooler in the intake manifold

**6 - Radiator fan -V7-**

- with radiator fan control unit -J293-
- removing and installing ⇒ [page 107](#)

**7 - Coolant hose**

- to coolant pipe below the intake manifold

**8 - Coolant hose**

- to engine oil cooler

**9 - Expansion reservoir**

- with coolant shortage warning light sender -G32-
- Check the cooling system for tightness ⇒ [page 109](#)

**10 - Connector**

**11 - Screw cap**

- Testing the pressure relief valve in the cap ⇒ [page 109](#)

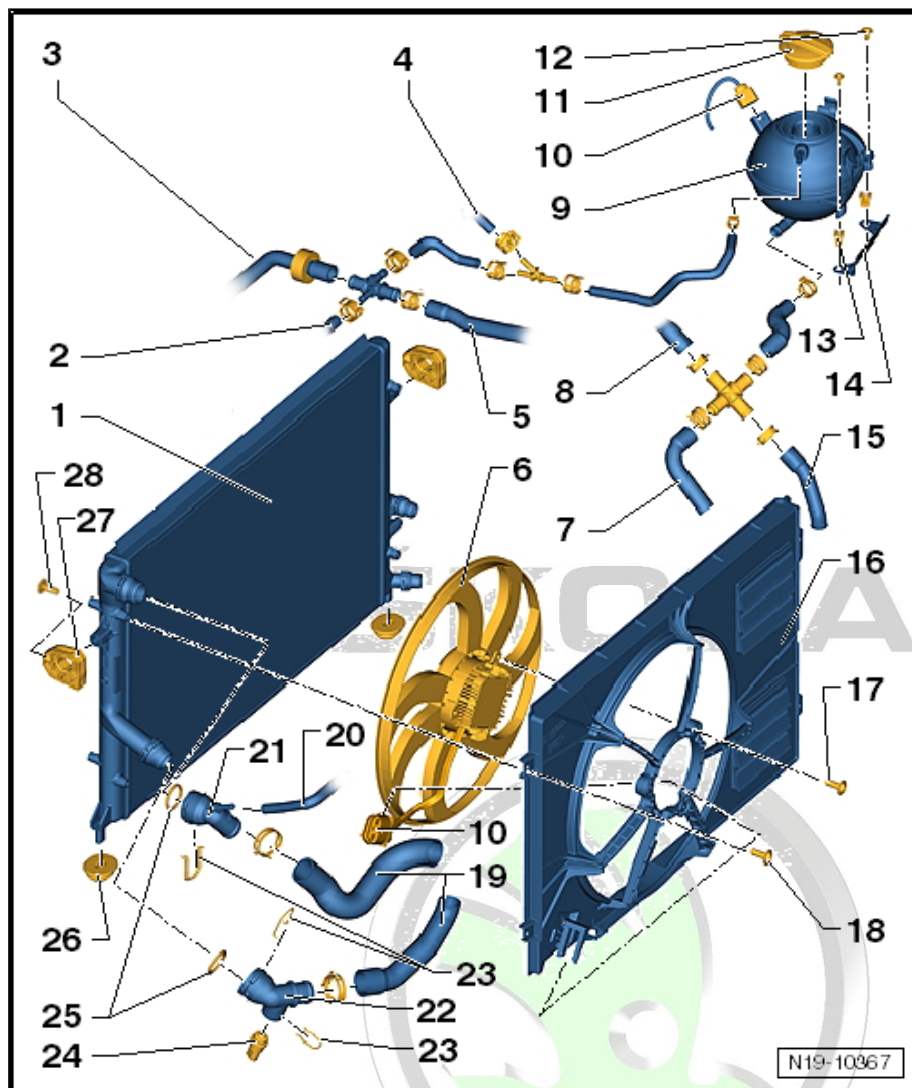

N19-10367

12 - 5 Nm

13 - Plastic inserts

- for fixing screws

14 - Support

15 - Coolant hose

- at coolant recirculation pump -V50-

16 - Fan shroud

- removing and installing ⇒ [page 107](#)

17 - 5 Nm

18 - 5 Nm

19 - Coolant hose

- at coolant regulator housing

20 - Coolant hose

- to heat exchanger of heating system

21 - Connection fittings

- for top coolant hose

22 - Connection fittings

- for bottom coolant hose

23 - Retaining clip

- check tightness

24 - Coolant temperature sender at radiator outlet -G83-

25 - O-ring

- replace if damaged

26 - Bottom radiator bearing

27 - Top radiator bearing

28 - 5 Nm

Protected by copyright. Copying for private or commercial purposes, in part or in whole, is not permitted unless authorised by ŠKODA AUTO A. S. ŠKODA AUTO A. S. does not guarantee or accept any liability with respect to the accuracy of the information contained in this document. © ŠKODA AUTO A. S. 2010

### 3.2 Removing and installing fan shroud for radiator fan -V7-

#### Removing

- Remove air filter ⇒ [page 171](#) .
- Unscrew the top fixing screws of the fan shroud -arrows-.
- Remove noise insulation ⇒ Body Work ⇒ Rep. gr. 50 .
- Disconnect the plug connection -1- and unscrew the bottom fixing screws of the fan shroud -arrows-.
- Remove fan shroud downwards.

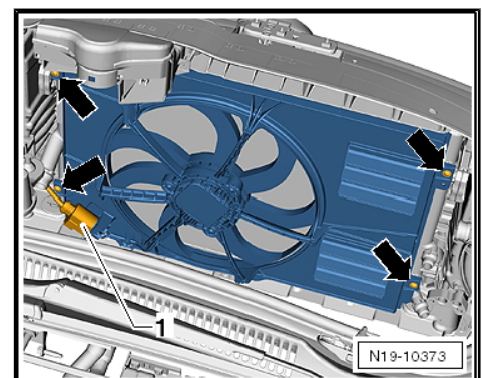



- Release screws -arrows- and remove radiator fan -V7 - .

**Install**

Installation is performed in the reverse order, pay attention to the following points:

**Tightening torques:**

Component	Nm
Radiator fan at fan shroud	5
Fan shroud at radiator	5

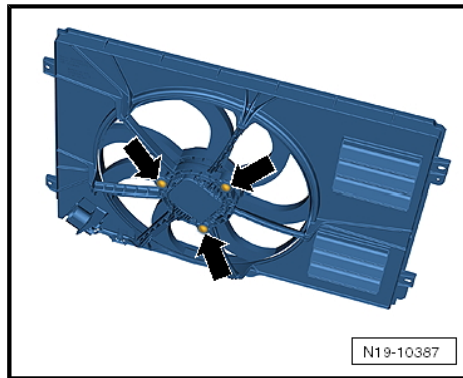

### 3.3 Removing and installing radiator

**Special tools and workshop equipment required**

- ◆ Catch pan , e.g. - VAS 6208-
- ◆ Pliers for spring strap clamps

**Removing**

- Drain coolant ⇒ [page 99](#) .
- Removing fan shroud ⇒ [page 107](#) .
- Remove top left coolant fitting fom radiator, to do so raise the retaining clip -arrow-.
- Detach the connection fitting of the top right coolant hose for the low temperature radiator.
- Remove front bumper ⇒ Body Work ⇒ Rep. gr. 63 .
- Removing headlight ⇒ Electrical System ⇒ Rep. gr. 94 .

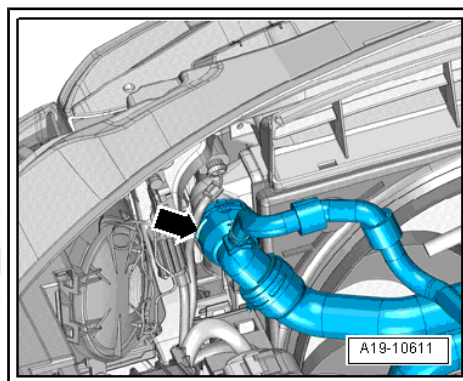

**Vehicles with air conditioning**



**WARNING**

*Do not open the refrigerant circuit of the air conditioning system.*

*In order to avoid damage to the condenser as well as to the refrigerant lines and hoses, ensure that the lines and hoses are not over-tensioned, kinked or bent.*

Protected by copyright. Copying for private or commercial purposes, in part or in whole, is not permitted unless authorised by ŠKODA AUTO A. S. ŠKODA AUTO A. S. does not guarantee or accept any liability with respect to the correctness of information in this document. Copyright by ŠKODA AUTO A. S. ©

- Screw out the fixing screws -2- of the condenser.

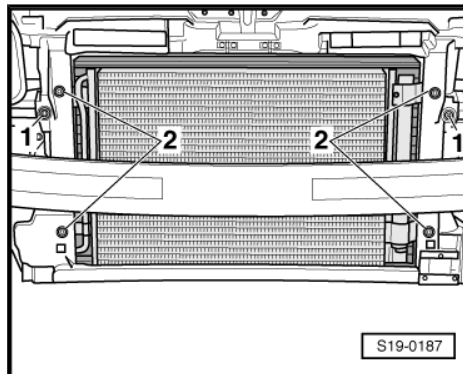

- Screw out the fixing screws -2- of the condenser.

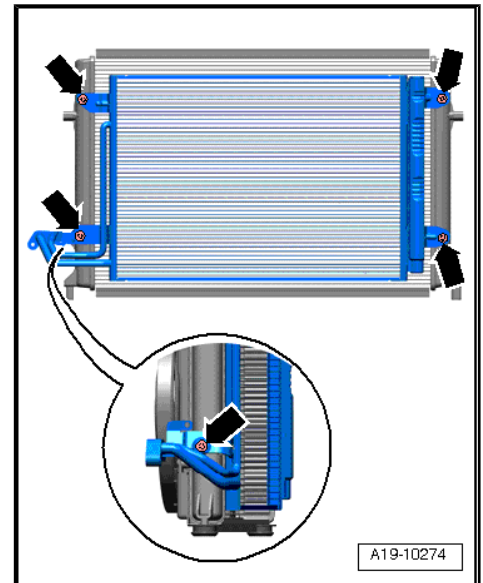

#### Continued for all vehicles

- Release screws -1- at radiator.
- Swivel the radiator slightly backwards.
- Unhook radiator upwards and remove downwards.

#### Install

Installation is performed in the reverse order, pay attention to the following points:

- Top up and bleed cooling system => [page 99](#) .

Tightening torques: => [page 106](#)

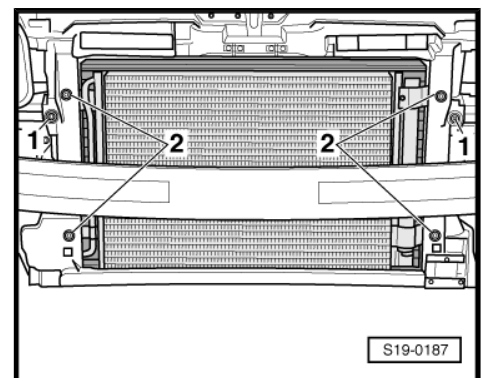

### 3.4 Checking the coolant system for leak-tightness

#### Special tools and workshop equipment required

- ◆ Cooling system testing device , e.g. -V.A.G 1274-
- ◆ Adapter for cooling system testing device , e.g. -V.A.G 1274/8-
- ◆ Adapter for cooling system testing device , e.g. -V.A.G 1274/9-

#### Test condition

- Engine is at operating temperature.

#### Test sequence



#### WARNING

*Hot steam may escape when the coolant expansion reservoir is opened. Wear safety goggles and safety clothing, in order to avoid eye injuries and scalding. Cover the cap with a cloth and open carefully.*

- Open compensation bottle.



- Position the cooling system testing device -V.A.G 1274- with adapter -V.A.G 1274/8 - on the coolant expansion reservoir.
- Using the hand pump of the testing device generate an over-pressure of approx. 0.1 MPa (1.0 bar).

If the pressure drops:

- Search position of the leak and repair fault.

**Testing the pressure relief valve in the cap**

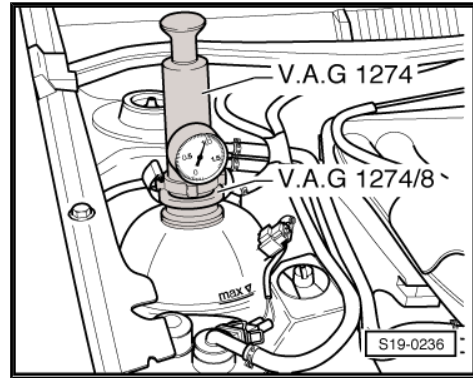

- Position the cooling system testing device -V.A.G 1274- with adapter -V.A.G 1274/9 - on the cap.
- Operate the handpump.
- The pressure relief valve should open at a pressure of 0.14...0.16 MPa (1.4...1.6 bar).

If the pressure relief valve does not open:

- Replace cap.

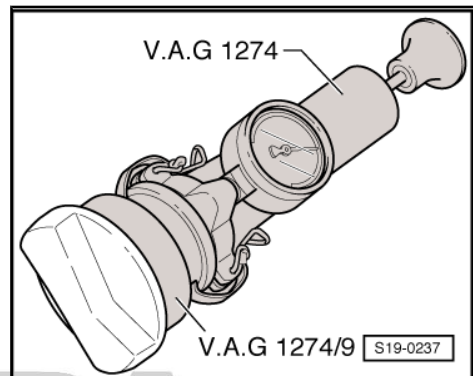

ŠKODA



Protected by copyright. Copying for private or commercial purposes, in part or in whole, is not permitted unless authorised by ŠKODA AUTO A. S. ŠKODA AUTO A. S. does not guarantee or accept any liability with respect to the correctness of information in this document. Copyright by ŠKODA AUTO A. S.



## 20 – Fuel supply system

### 1 Fuel tank and fuel delivery unit

#### Note

- ◆ Fuel hoses at the engine must only be secured with spring-type clips ⇒ electronic catalogue of original parts .
- ◆ Use pliers for spring strap clamps to fit the spring strap clips.

#### 1.1 Fuel tank for vehicles manufactured up to 06.10 - Summary of components

##### 1 - Feed line

- black
- check for firm seating

##### 2 - Return-flow line

- blue
- check for firm seating

##### 3 - Sealing ring

- replace
- insert dry into the opening of the fuel tank
- only moisten the inner seal of the flange with fuel for fitting purposes

##### 4 - Fuel delivery unit

- removing and installing ⇒ [page 122](#)
- inspecting fuel pump ⇒ [page 128](#)
- note the installed position of the fuel tank ⇒ [page 112](#)
- with sender for fuel gauge display -G-
- Removing and installing the sender for fuel gauge display -G- ⇒ [page 127](#)
- Clean strainer if dirty

##### 5 - Lock ring, 110 Nm

- check for firm seating
- use wrench -T30101 (3087)- for removing and installing

##### 6 - Fuel pump control unit -J538 -

- after replacing, adapt the engine control unit -J623- to the fuel pump control unit -J538- ⇒ Vehicle diagnostic, testing and information system VAS 5051

##### 7 - Screw cap

- replace if damaged

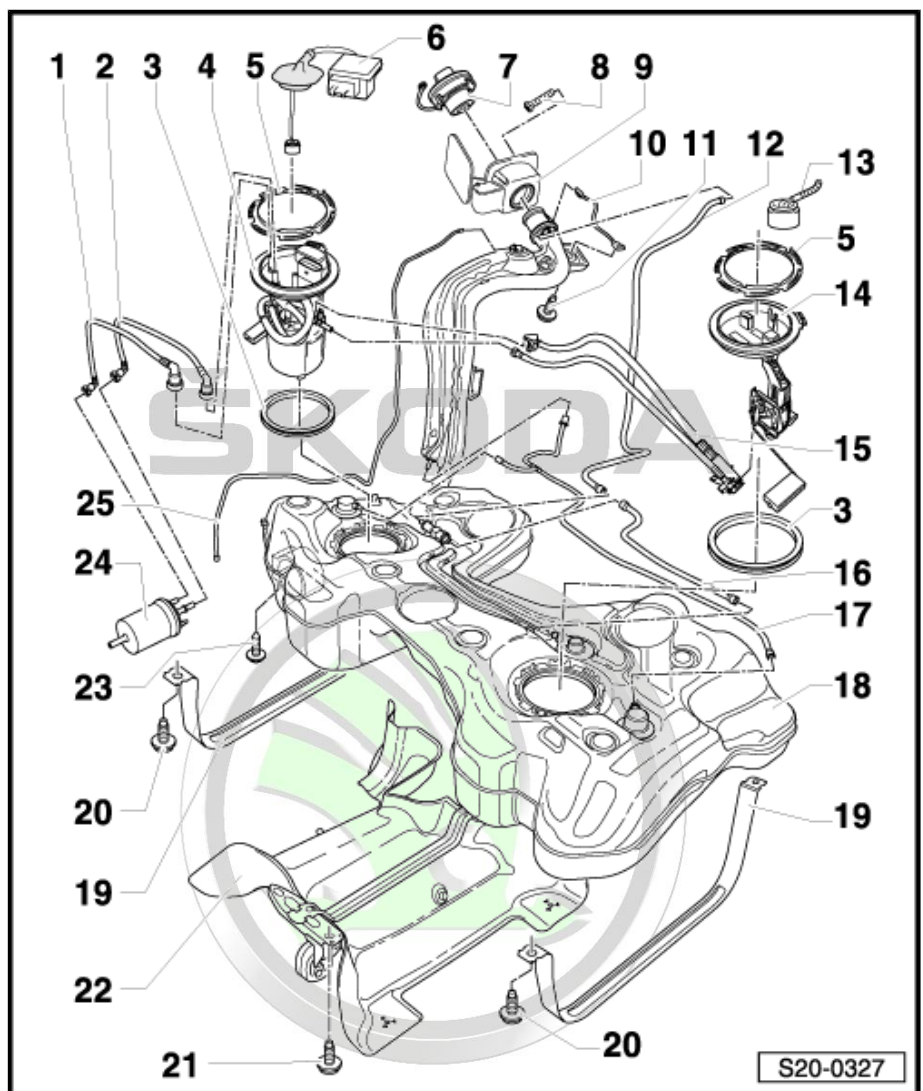

Protected by copyright. Copying for private or commercial purposes, in part or in whole, is not permitted unless authorised by ŠKODA AUTO A. S. ŠKODA AUTO A. S. does not guarantee or accept any liability with respect to the correctness of information in this document. Copyright by ŠKODA AUTO A. S.®



## 8 - Fixing screw

## 9 - Fuel tank lid unit

- with rubber bowl
- removing and installing ⇒ Body Work ⇒ Rep. gr. 55

## 10 - Earth connection

- check for firm seating

## 11 - 11 Nm

## 12 - Tank ventilation

## 13 - Connector

- for fuel gauge sender -2- -G169-

## 14 - Fuel gauge sender 2 -G169-

- removing and installing ⇒ [page 143](#)

## 15 - Suction spray pump

- clipped in place on fuel gauge sender 2 -G169-
- removing and installing ⇒ [page 145](#)

## 16 - Tank ventilation

## 17 - Vent line

## 18 - Fuel tank

- removing and installing ⇒ [page 117](#)

## 19 - Tensioning strap

- Check fitting position

## 20 - 25 Nm

- replace

## 21 - 23 Nm

## 22 - Heat shield

- riveted together with hanger of exhaust system

## 23 - 3 Nm

## 24 - Fuel filter

- Summary of components ⇒ [page 115](#)

## 25 - Vent line

- clipped in place on the side of the fuel tank
- check for firm seating

# ŠKODA



Protected by copyright. Copying for private or commercial purposes, in part or in whole, is not permitted unless authorised by ŠKODA AUTO A. S. ŠKODA AUTO A. S. does not guarantee or accept any liability with respect to the correctness of information in this document. Copyright by ŠKODA AUTO A. S. ©

### Fitting position of the flange of the fuel delivery unit and the fuel gauge sender -2- -G169-

The marking on the flange must be aligned with marking on the fuel tank -arrows-.



#### Note

*The arrows on the fuel tank are hardly visible due to the floor panel.*

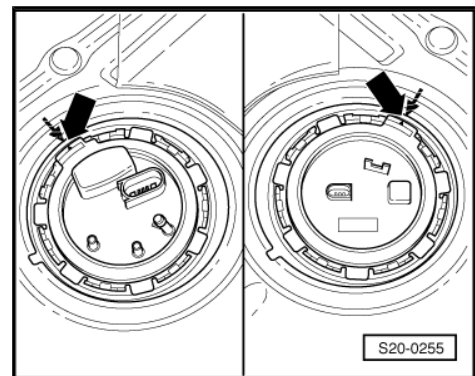

## 1.2 Fuel tank for vehicles manufactured as of 06.10 - Summary of components

### 1 - Mounting part

### 2 - Screw cap

- replace if damaged

### 3 - Earth connection

- check for firm seating

### 4 - 11 Nm

### 5 - Guide

### 6 - 25 Nm

- replace

### 7 - Fuel tank

- removing and installing  
⇒ [page 120](#)

### 8 - Circlip

### 9 - Bracket for the exhaust system

### 10 - Tensioning strap

- Check fitting position

### 11 - Heat shield

### 12 - Feed line

- to fuel rail
- check for firm seating

### 13 - Fuel filter

- removing and installing  
⇒ [page 115](#)

### 14 - Vent line

- clipped in place on the side of the fuel tank
- check for firm seating

### 15 - Sealing ring

- replace
- to be inserted dry into the opening of the fuel tank
- only moisten the inner seal of the flange with fuel for fitting purposes

### 16 - Fuel delivery unit

- removing and installing ⇒ [page 125](#)
- inspecting fuel pump ⇒ [page 128](#)
- note the correct installed position of the fuel tank ⇒ [page 114](#)
- with sender for fuel gauge display -G-
- Removing and installing the sender for fuel gauge display -G- ⇒ [page 127](#)
- Clean strainer if dirty

### 17 - Lock ring, 110 Nm

- check for firm seating
- use wrench -T30101 (3087)- for removing and installing

### 18 - Feed line

- black
- clipped in place on the side of the fuel tank

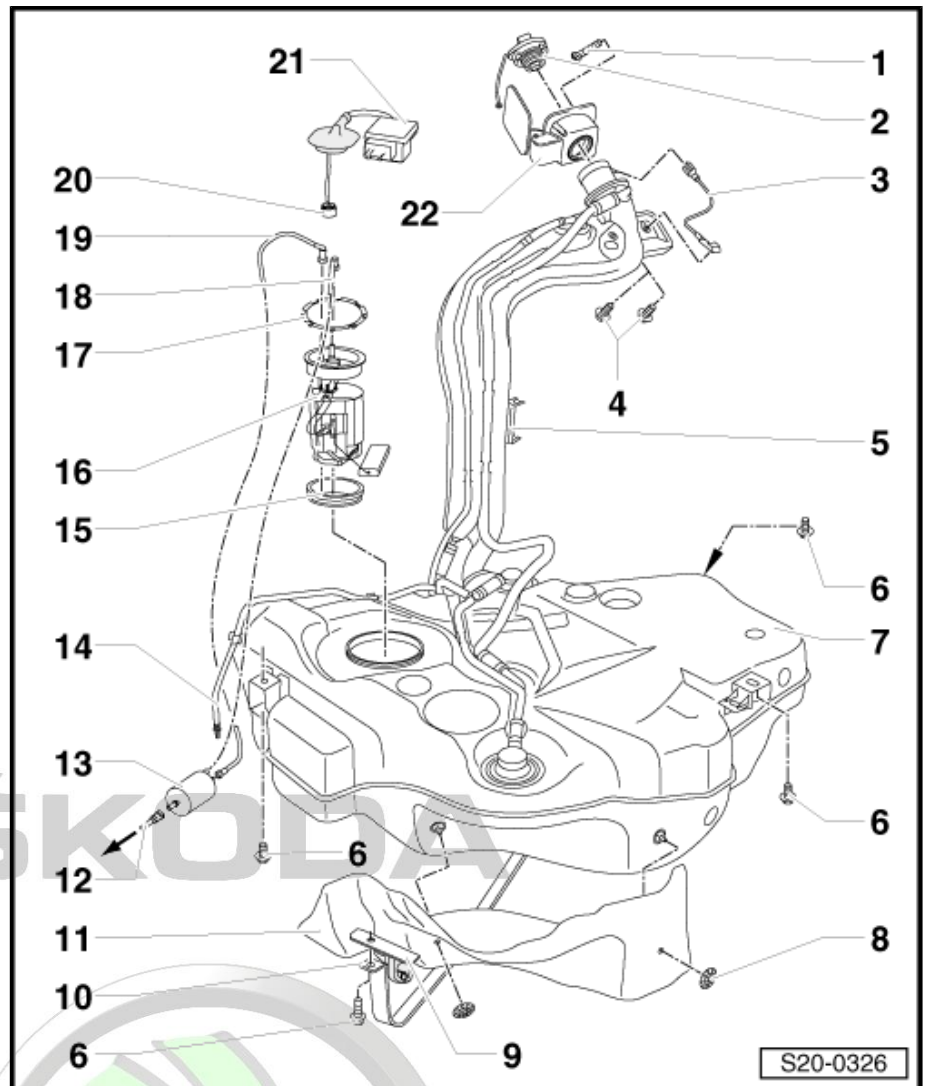

Protected by copyright. Copying for private or commercial purposes, in part or in whole, is not permitted unless authorised by SKODA AUTO A. S. SKODA AUTO A. S. does not guarantee or accept any liability with respect to the correctness of information in this document. Copyright by SKODA AUTO A. S.



- check for firm seating

#### 19 - Return-flow line

- blue
- clipped in place on the side of the fuel tank
- check for firm seating

#### 20 - Fuel pump control unit -J538 -

- after replacing, adapt the engine control unit -J623- to the fuel pump control unit -J538- → Vehicle diagnostic, testing and information system VAS 5051
- check → Vehicle diagnostic, testing and information system VAS 5051

#### 21 - Fuel tank lid unit

- with rubber bowl
- removing and installing → Body Work → Rep. gr. 55

# ŠKODA

#### Fitting location of the fuel delivery unit

The peg -2- on the fuel delivery unit must be between the pegs -1- and -3-.



#### Note

- ◆ *The -arrow- shows the direction of travel.*
- ◆ *The fuel delivery unit can only be installed in this position.*

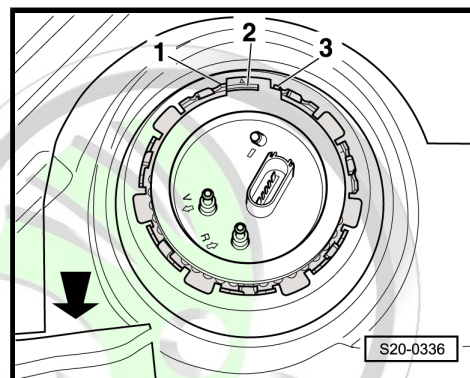

Protected by copyright. Copying for private or commercial purposes, in part or in whole, is not permitted unless authorised by ŠKODA AUTO A. S. ŠKODA AUTO A. S. does not guarantee or accept any liability with respect to the correctness of information in this document. Copyright by ŠKODA AUTO A. S. ©

## 1.3 Fuel filter - Summary of components

### 1 - Fuel filter

- with installed pressure limiting valve for fuel return-flow line

Opening pressure:  
0.60...0.68 MPa (6.0...  
6.8 bar)

- do not interchange connections
- Fitting position  
⇒ [page 115](#)

### 2 - Fuel feed line

- black
- from fuel tank
- press in securing ring in order to unlock

### 3 - Fuel return-flow line

- blue
- to fuel tank
- press in securing ring in order to unlock

### 4 - Fuel feed line

- black
- to the engine
- press in securing ring in order to unlock

### 5 - 3 Nm

### 6 - Support

- for fuel filter
- attached to the fuel tank

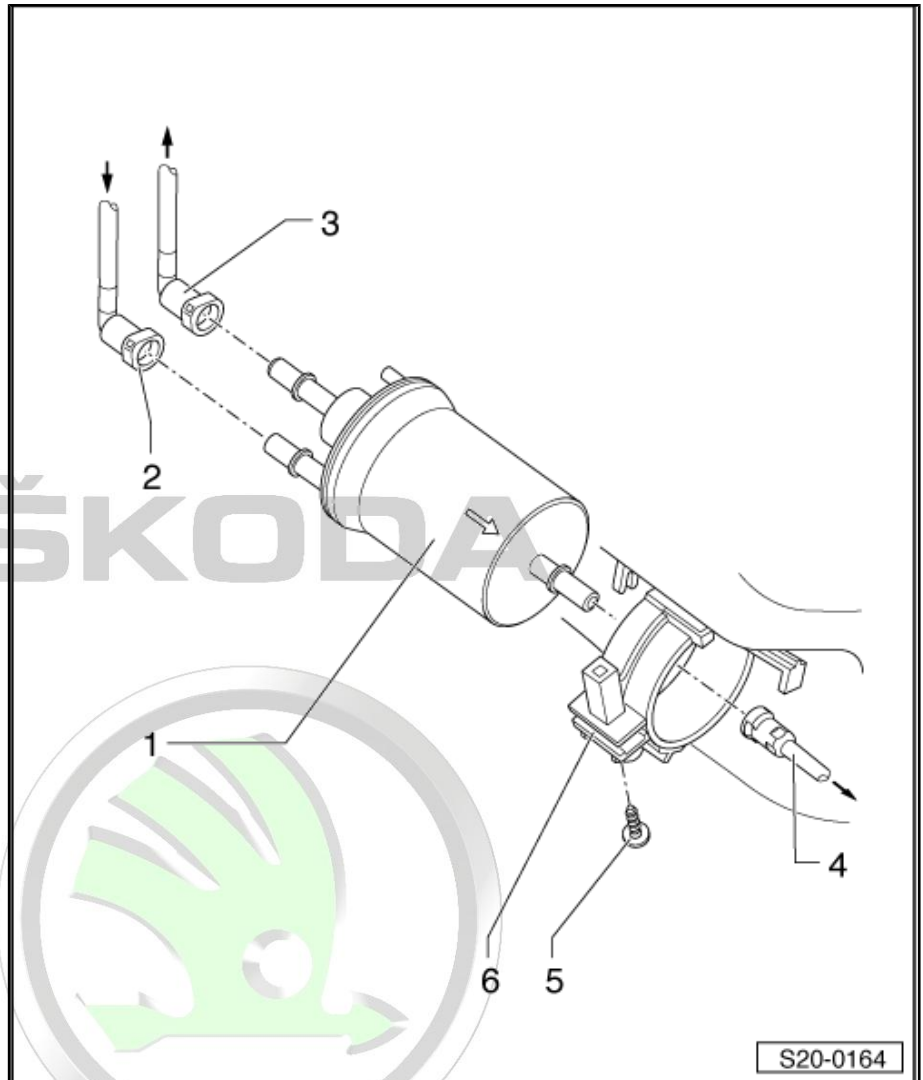

### Fitting position of the fuel filter

The pin -2- at the filter housing must engage in the recess -1- of the bracket.

unless authorised by ŠKODA AUTO A. S. ŠKODA AUTO A. S. does not guarantee or accept any liability with respect to the correctness of information in this document. Copyright by ŠKODA AUTO A. S.

The direction of flow is marked by arrows.

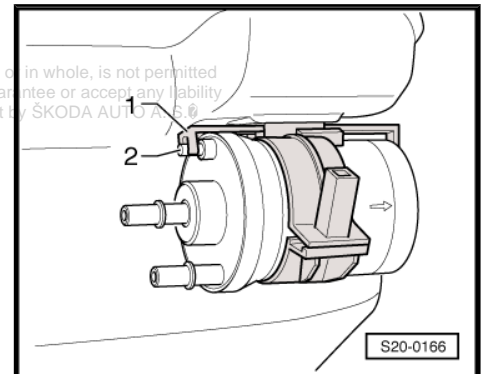

## 1.4 Extract fuel from the fuel tank

### Special tools and workshop equipment required

- ◆ Hose adapter , e.g. -V.A.G 1318 -16 -
- ◆ Adapter , e.g. -V.A.G 1318 -17-
- ◆ Measuring tool set , e.g. -V.A.G 1594 C-



- ◆ Battery
- ◆ Fuel tank

**i Note**

If the fuel pump is defective, suction off fuel using a fuel suction device, e.g. -VAS 5190- .

**Work procedure**

**i Note**

- ◆ *Safety precautions when working on the fuel supply system*  
⇒ [page 3](#) .
- ◆ *Rules of cleanliness when working on the fuel supply system*  
⇒ [page 5](#) .
- Switch off the ignition and all electrical components and take out the ignition key.
- Remove rear seat bench with brackets ⇒ Body Work ⇒ Rep. gr. 72 .
- Remove floor covering under the rear seat bench.
- Unclip the cover -4- with the fuel pump control unit -J538- -1-.

**Vehicles with auxiliary heating.**

- Unplug the 2-pin plug of the dosing pump -V54- .

**Continued for all vehicles**

- Unplug the 5-pin plug -1- from the black feed line -2-.

**i Note**

Press in the securing ring in order to unlock the line.

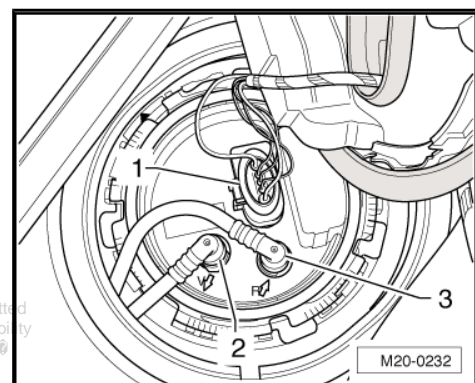
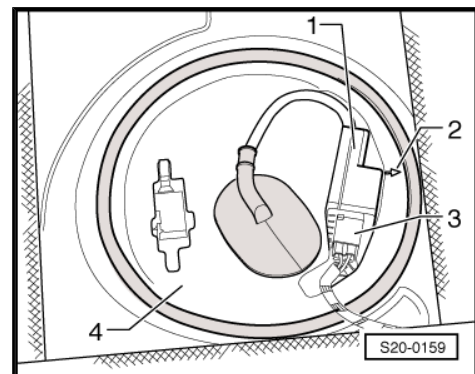
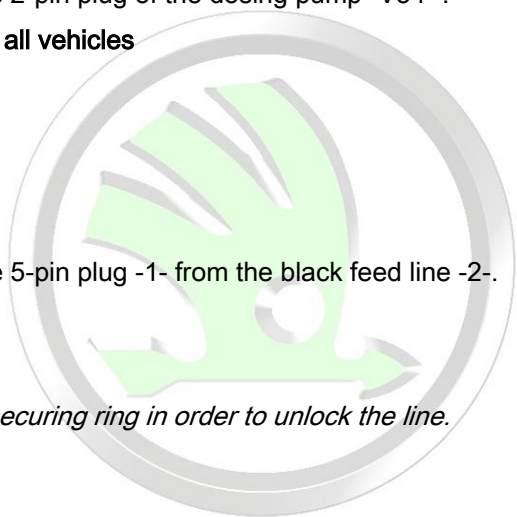

Protected by copyright. Copying for private or commercial purposes, in part or in whole, is not permitted unless authorised by ŠKODA AUTO A. S. ŠKODA AUTO A. S. does not guarantee or accept any liability with respect to the correctness of information in this document. Copyright by ŠKODA AUTO A. S.

- Connect the adapter -V.A.G 1318/16- with the adapter -V.A.G 1318/17- and fit this „drain pipe“ thus prepared onto the feed support of the fuel delivery unit.
  - Hold the „drain pipe“ in a suitable fuel tank.
  - Connect the battery and the contacts of the fuel pump with adapter cables -A- from the adapter cable set -V.A.G 1594/C- as follows:  
Battery positive terminal (+) to contact -1- of the fuel pump  
Battery negative terminal (+) to contact -5- of the fuel pump
- The fuel pump runs and suctions off fuel.



**WARNING**

*In order to prevent an overflow of fuel in case of a too small fuel tank, the fuel pump must not run unattended.*

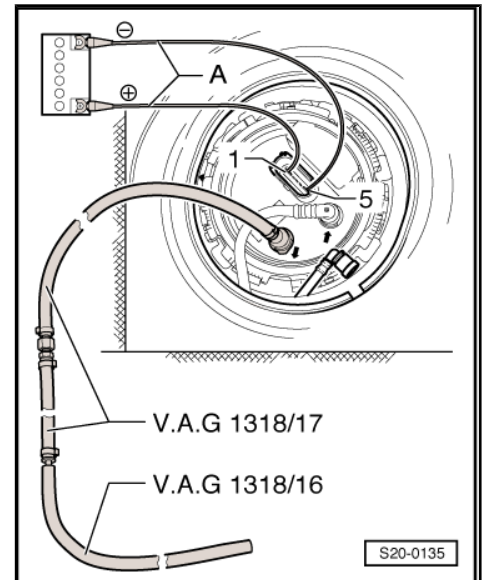

## 1.5 Removing and installing fuel tank for vehicles manufactured up to 06.10

### Special tools and workshop equipment required

- ◆ Engine/gearbox jack , e.g. -V.A.G 1383 A-

Protected by copyright. Copying for private or commercial purposes, in part or in whole, is not permitted without the prior written authorisation of SKODA AUTO A. S. SKODA AUTO A. S. does not guarantee or accept any liability with respect to the correctness of information in this document. Copyright by SKODA AUTO A. S. ©

### Removing

- The fuel tank must be empty for weight reasons when removing it, if necessary suction the fuel out of the fuel tank  
=> [page 115](#) .

### Note

- ◆ *Safety precautions when working on the fuel supply system*  
=> [page 3](#) .
- ◆ *Rules of cleanliness when working on the fuel supply system*  
=> [page 5](#) .
- Switch off all electrical components and withdraw key from ignition lock.
- Remove rear seat bench with brackets => Body Work => Rep. gr. 72 .
- Remove floor covering under the rear seat bench.
- Unclip the cover -4- with the fuel pump control unit -J538- -1-.

### Vehicles with auxiliary heating.

- Unplug the 2-pin plug of the dosing pump -V54- .
- Remove the rubber grommet from the cover of the fuel delivery unit and pull out the wiring.

### Continued for all vehicles

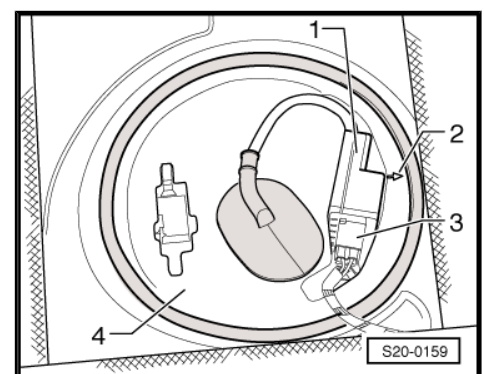



- Unplug the 5-pin plug -1- from the fuel tank.

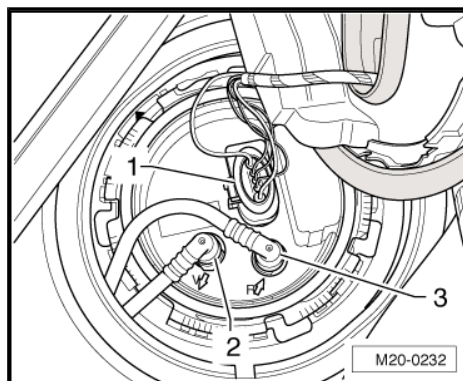

- Remove the cover of the fuel gauge sender -2- -G169- (in the figure on the right) and unplug the plug -right arrows-.
- Open the fuel tank cap and clean around the fuel filler neck.
- Unscrew the cap from the fuel filler neck.
- Seal the filler neck with a clean foam piece in order to avoid any foreign bodies from entering.
- Remove the rear right wheelhouse liner ⇒ Body Work ⇒ Rep. gr. 66 .

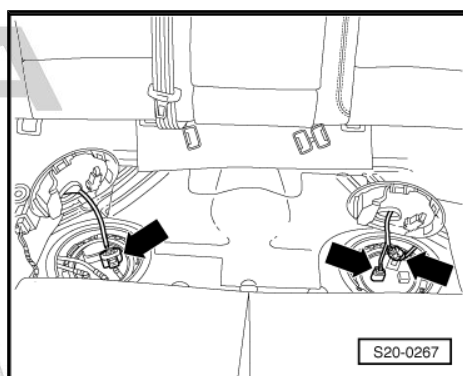

- Unscrew screws -1- for filler neck on the body.
- Unclip the electrical cable from the bracket -2- at the top and bottom of the filler neck.

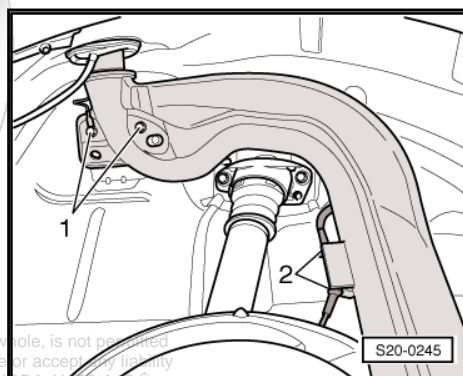

Protected by copyright. Copying for private or commercial purposes, in part or in whole, is not permitted unless authorised by ŠKODA AUTO A. S. ŠKODA AUTO A. S. does not guarantee or accept any liability with respect to the correctness of information in this document. Copyright by ŠKODA AUTO A. S.

- Disconnect vent line -1- (white) and fuel feed line -2- (black) at the connection point.



**Note**

*Press in the securing ring in order to unlock the line.*

**Vehicles with auxiliary heating.**

- Separate the fuel line from the dosing pump -V54- .

**Continued for all vehicles**

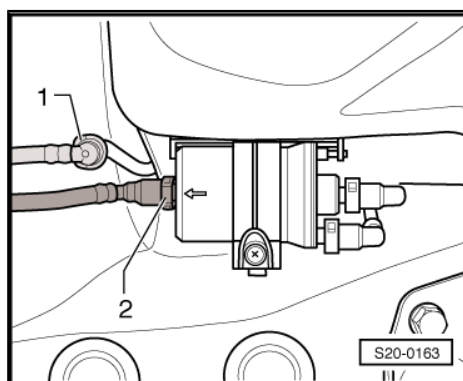

- Remove rear tunnel bridge -arrows-.
- Unhook the rear silencer from two retaining straps.
- Slacken nuts of double clamp.
- Remove screws for rear exhaust pipe hanger.

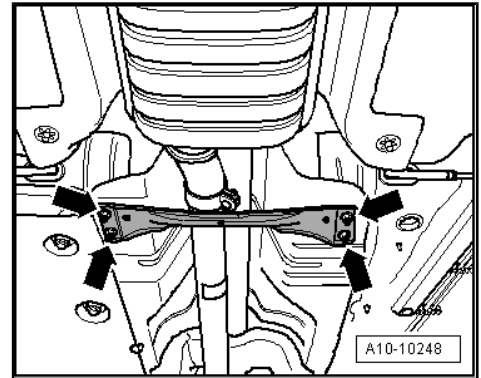

- Remove the rear silencer.
- First unscrew screws -2, 5- and -6-.
- Support the fuel tank using the engine/gearbox jack -V.A.G 1383 A- .
- Unscrew the screws for the tensioning straps -1, 3, 4- and -7-.

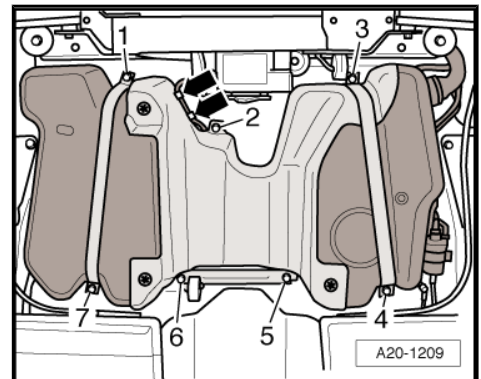

- Lower slightly the fuel tank using the engine/gearbox jack - V.A.G 1383 A- .
- Then remove the fuel tank from the engine/gearbox jack - V.A.G 1383 A- and pull through the filler neck between the body and the rear axle with the help of a second mechanic.

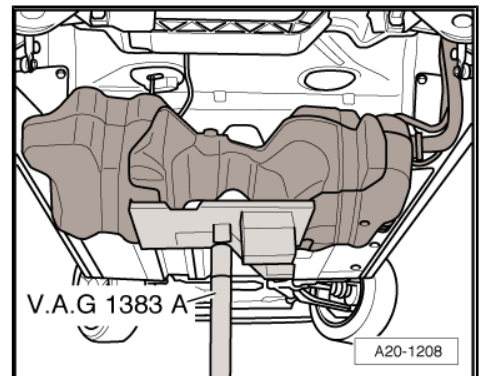

### Install

- Check both earth connections for corrosion, if necessary remove corrosion.



- Check fitting position of the earth lead -1-.
- The plug -1- must tightly fit on the plate ring -2-.
- The contact tab -4- must be hung in the fuel tank -3- and secured with the spacer bush -5-.
- Pull through the filler neck between the body and the rear axle with the help of a second mechanic. Then position the fuel tank onto the engine/gearbox jack -V.A.G 1383 A- .

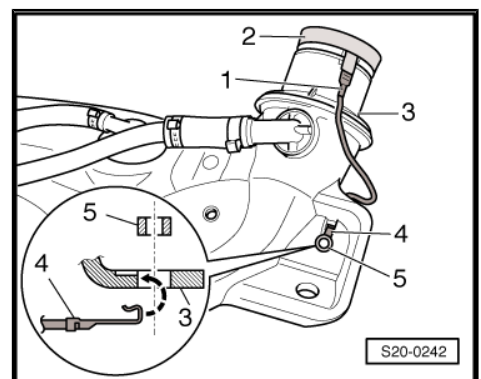

Further installation occurs in reverse order. Pay attention to the following:

- ◆ Lay the vent and fuel lines without any kinks.
- ◆ Do not mix-up the feed line and the return-flow line (the return-flow line is blue, the feed line is black).
- ◆ Make sure the line connections fit tightly.
- ◆ Check the earth connection of the fuel tank at the body on the filler neck.
- ◆ After installing the fuel tank, check whether the lines are also clipped in place on the fuel tank.

SKODA AUTO A. S. does not guarantee or accept any liability with respect to the correctness of information in this document. Copyright by ŠKODA AUTO A. S.



- Clip on cover -4- with fuel pump control unit -J538- -1-.
- The arrow -2- on the cover points in direction of travel.

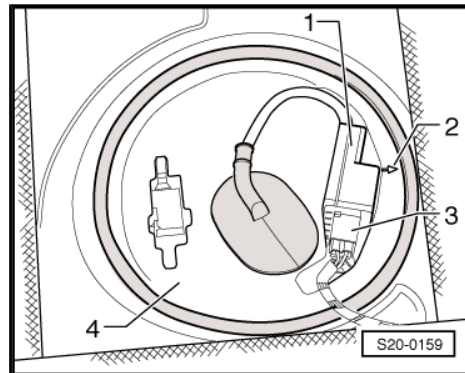

## 1.6 Removing and installing fuel tank for vehicles manufactured as of 06.10

### Special tools and workshop equipment required

- ◆ Engine/gearbox jack , e.g. -V.A.G 1383 A-

### Removing

- The fuel tank must be empty for weight reasons when removing it, if necessary suction the fuel out of the fuel tank  
⇒ [page 115](#) .



### Note

- ◆ *Safety precautions when working on the fuel supply system*  
⇒ [page 3](#) .
- ◆ *Rules of cleanliness when working on the fuel supply system*  
⇒ [page 5](#) .
- Switch off the ignition and all electrical components and take out the ignition key.
- Removing rear seat bench ⇒ Body Work ⇒ Rep. gr. 72 .
- Unclip the cover -4- with the fuel pump control unit -J538- -1-.



### Note

*For vehicles with auxiliary heating, the plug connection for the dosing pump -V54- must also be disconnected.*

Protected by copyright. Copying for private or commercial purposes, in part or in full, is not permitted unless authorised by ŠKODA AUTO A. S. ŠKODA AUTO A. S. does not guarantee the accuracy or accept liability with respect to the correctness of information in this document. Copyright by ŠKODA AUTO A. S.

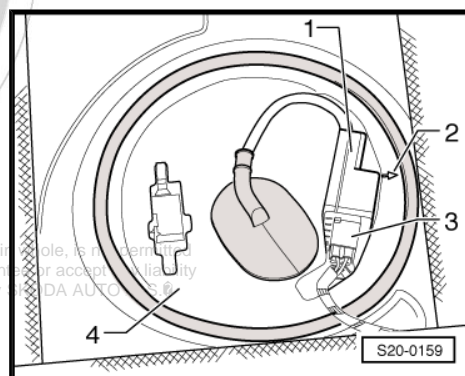

- Unplug the 5-pin plug -1- from the fuel pump.
- Clean around the fuel filler neck.
- Unscrew right rear wheel.
- Remove the rear right wheelhouse liner ⇒ Body Work ⇒ Rep. gr. 66 .

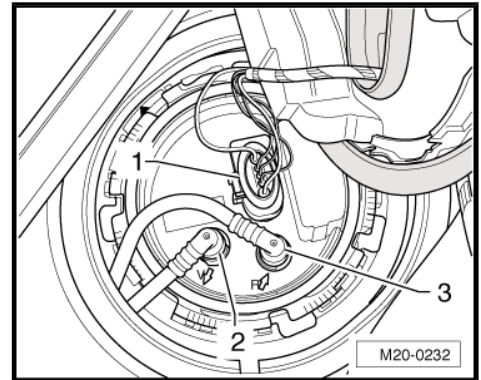

- Unscrew screws -1- for filler neck on the body.
- Unclip the electrical cable from the bracket -2- at the top and bottom of the filler neck.

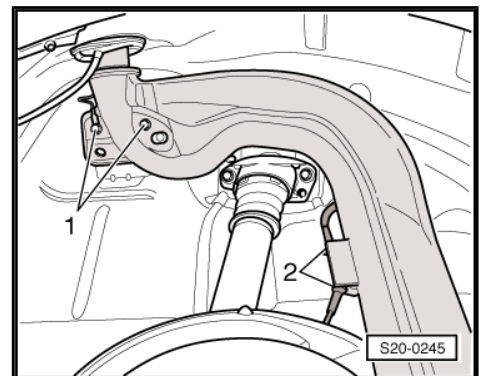

- Disconnect vent line -1- (white) and fuel feed line -2- (black) at the connection point.

**i Note**

- ◆ For vehicles with auxiliary heating, the fuel line for the dosing pump -V54- must also be disconnected.
- ◆ Press in the securing ring in order to unlock the line.

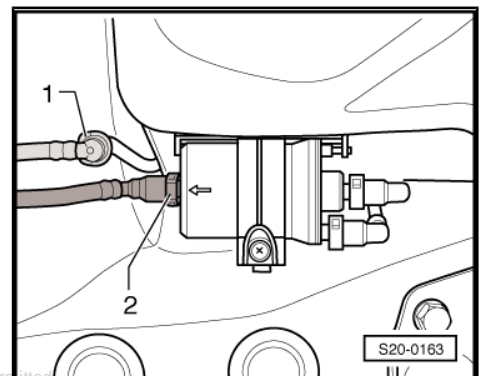

- Remove middle and rear silencer ⇒ [page 191](#) .

- Release fixing screws -2- and -4- and remove the tensioning strap.
- Support fuel tank using the engine/gearbox jack -V.A.G 1383 A- .
- Release fixing screws -1- and -3-.
- Slightly lower the fuel tank.

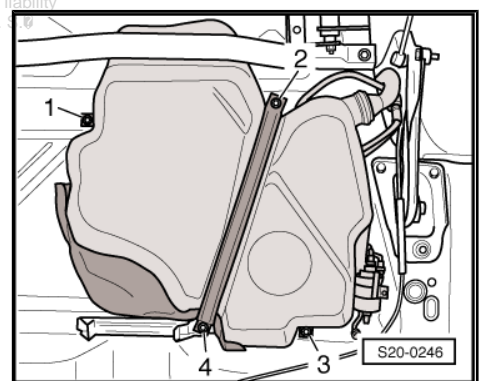

**i Note**

The filler neck must be „extracted“ between structure and rear axle Lift down the fuel tank with a 2nd mechanic from engine/ gearbox jack -V.A.G 1383 A- .

**Install**

- Check both earth connections for corrosion, if necessary remove corrosion.



- Check fitting position of the earth lead -1-.
- The plug -1- must tightly fit on the plate ring -2-.
- The contact tab -4- must be hung in the fuel tank -3- and secured with the spacer bush -5-.
- Pull through the filler neck between the body and the rear axle with the help of a second mechanic. Then position the fuel tank onto the engine/gearbox jack -V.A.G 1383 A- .

Further installation occurs in reverse order. Pay attention to the following:

- ◆ Lay the vent and fuel lines without any kinks.
- ◆ Do not mix-up the feed line and the return-flow line (the return-flow line is blue, the feed line is black).
- ◆ Make sure the line connections fit tightly.
- ◆ Check earth connection of fuel tank/body at filler neck.
- ◆ After installing the fuel tank, check whether the lines are also clipped in place on the fuel tank.
- Clip on cover -4- with fuel pump control unit -J538- -1-.
- The arrow -2- on the cover points in direction of travel.

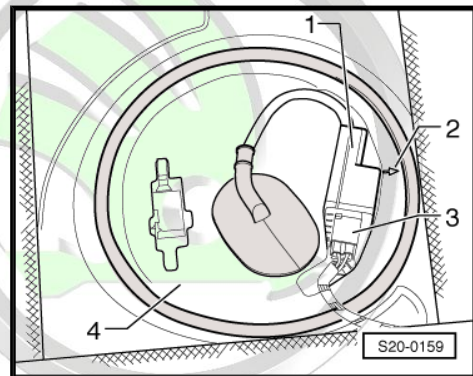
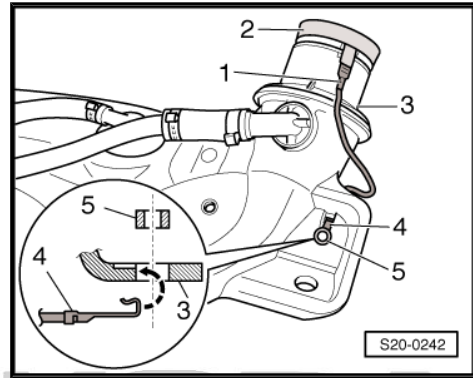

## 1.7 Removing and installing fuel delivery unit for vehicles manufactured up to 06.10

Copyright. Copying for private or commercial purposes, in part or in whole, is not permitted without the prior written consent of ŠKODA AUTO A. S. ŠKODA AUTO A. S. does not guarantee or accept any liability with respect to the correctness of information in this document. Copyright by ŠKODA AUTO A. S. ©

### Special tools and workshop equipment required

- ◆ Key -T30101 (3087)-
- ◆ Protective gloves

### Removing

- The fuel tank must not be more than 1/3 full.



### Note

- ◆ *Empty the fuel tank if necessary ⇒ [page 115](#).*
- ◆ *Safety precautions when working on the fuel supply system ⇒ [page 3](#).*
- ◆ *Rules of cleanliness when working on the fuel supply system ⇒ [page 5](#).*
- Switch off the ignition and all electrical components and take out the ignition key.
- Remove rear seat bench with brackets ⇒ Body Work ⇒ Rep. gr. 72 .

- Remove floor covering under the rear seat bench.
- Unclip the cover -4- with the fuel pump control unit -J538-1-.

**Vehicles with auxiliary heating.**

- Unplug the 2-pin plug of the dosing pump -V54- .

**Continued for all vehicles**

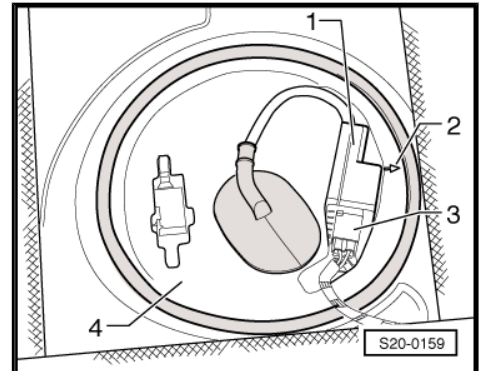

- Disconnect the plug as well as the black fuel feed line -1- and the blue fuel return-flow line -2- from the flange.



**Note**

*Press in the securing ring in order to unlock the line.*

**Vehicles with auxiliary heating.**

- Pull out the suction line for the dosing pump -V54- (slacken lower clamp).

**Continued for all vehicles**

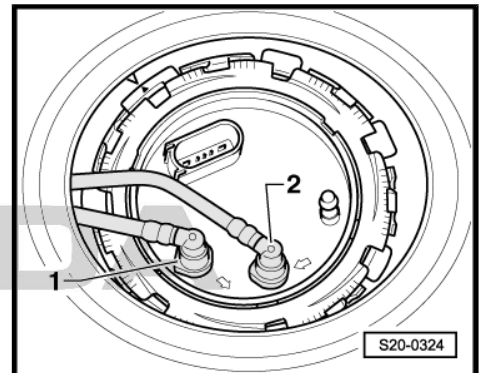

- Open lock ring with wrench -T30101- .

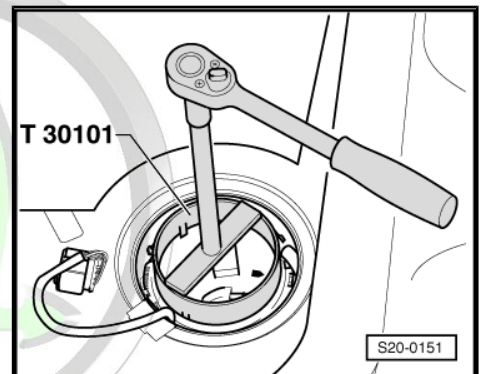

- Slightly raise the closing flange and check if the spring -2- is still fastened on the flange -1-.

If the spring -2- is loose on the guide pipe -3-, hold it with your fingers while removing the closing flange.

- Pull out closing flange and gasket ring of the fuel delivery unit from the opening of the fuel tank and place to the side with the connected lines.
- Remove the suction jet pump from the fuel gauge sender 2 - G169- => [page 143](#) .

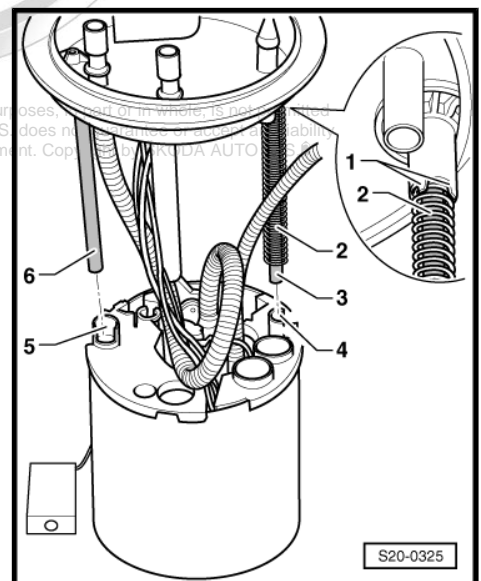



- Separate through the opening of the fuel tank the fuel line -1- to the suction jet pump, to do so press the release button.
- Separate the fuel delivery line -2- from the fuel delivery unit.



**Note**

- ◆ You must wear protective gloves for removing the fuel delivery unit.
  - ◆ Take the fuel delivery unit out of the fuel tank in such a way that the electrical cables and the fuel hoses are not damaged and that the float arm of the sender for the fuel gauge display -G- is not bent.
  - ◆ You must empty the old delivery unit before disposing of it if you wish to replace the fuel delivery unit.
- Pull the fuel delivery unit out of the opening of the fuel tank.

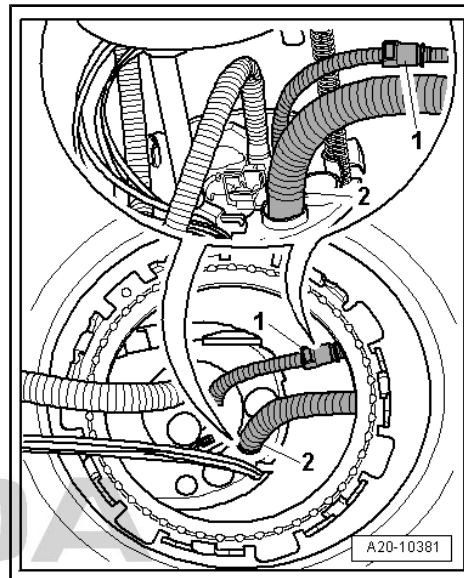

**Install**

Installation occurs in reverse order. Pay attention to the following:

- Insert the new dry gasket ring into the opening of the fuel tank and moisten only from the inside with fuel for installing the closing flange.
- Insert the fuel delivery unit into the fuel tank with the closing flange placed to the side. Thus, do not bend the float arm of the fuel gauge sender unit -G- .
- Install the fuel delivery unit and the fuel line.
- The spring -2- must be fastened to the retaining lugs -1- of the closing flange.
- First of all guide the guide pipe -3- into the guide bore -4-.
- Then lower the closing flange in such a way that the guide pipe -6- locks into the guide bore -5-.

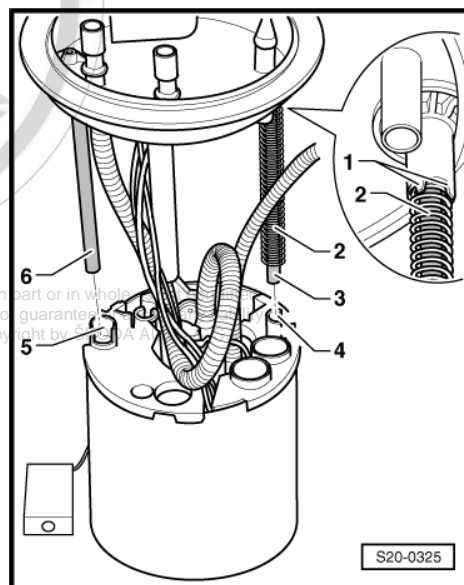

Protected by copyright. Copying for private or commercial purposes, in part or in whole, is prohibited without the written permission of ŠKODA AUTO A. S. ŠKODA AUTO A. S. does not guarantee the correctness of information in this document. Copyright by ŠKODA AUTO A. S.

**i** Note

Pay attention that the electrical cables -1- and the fuel feed line -3- are routed according to the illustration and the float arm -2- is not blocked.

- Press the closing flange down and bring it into the installation position.

Further information:

ŠKODA

- ◆ Fitting position of the fuel delivery unit: The peg -2- at the closing flange must be located between the pegs -1- and -3-. The -thick arrow- points in the direction of travel.
- ◆ Tighten the lock ring to 110 Nm.
- ◆ Do not interchange feed line and return-flow line.
- ◆ Make sure the fuel lines fit tightly.
- ◆ After installing the fuel delivery unit, check whether the feed line and the return-flow line are still clipped in place on the fuel tank.

## 1.8 Removing and installing fuel delivery unit for vehicles manufactured as of 06.10

### Special tools and workshop equipment required

- ◆ Key -T30101 (3087)-

### Removing

- The fuel tank must not be more than  $\frac{3}{4}$  full.

**i** Note

- ◆ If necessary, extract fuel from the fuel tank ⇒ [page 115](#) .
- ◆ Observe the safety instructions before starting fitting work ⇒ [page 3](#) .
- ◆ Observe rules for cleanliness ⇒ [page 5](#) .
- Switch off the ignition and all electrical components and take out the ignition key.
- Removing rear seat bench ⇒ Body Work ⇒ Rep. gr. 72 .

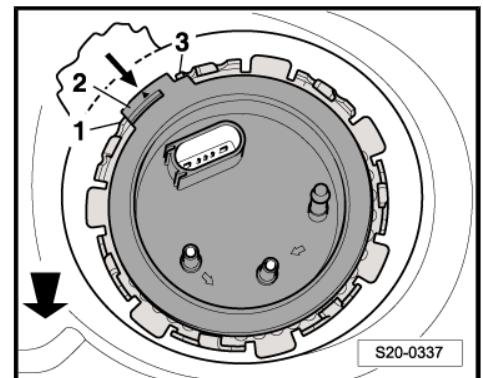
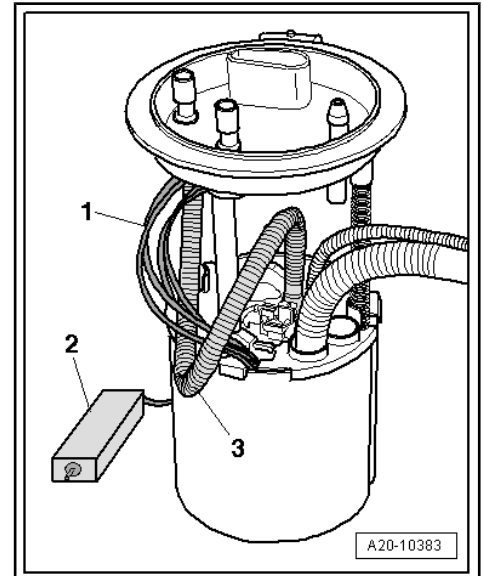



- Unclip the cover -4- with the fuel pump control unit -J538- -1-.



**Note**

*For vehicles with auxiliary heating, the plug connection for the dosing pump -V54- must be disconnected additionally.*

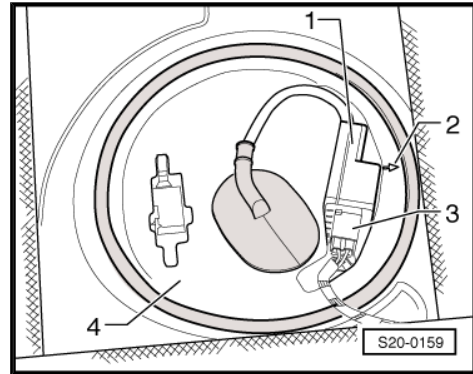

- Unplug the 5-pin plug, the black feed line -1- and the blue return-flow line -2-.



**Note**

- ◆ Press in the securing ring in order to unlock the line.
- ◆ For vehicles with auxiliary heating the suction line for the dosing pump -V54- must be pulled out additionally (open lower clamp).

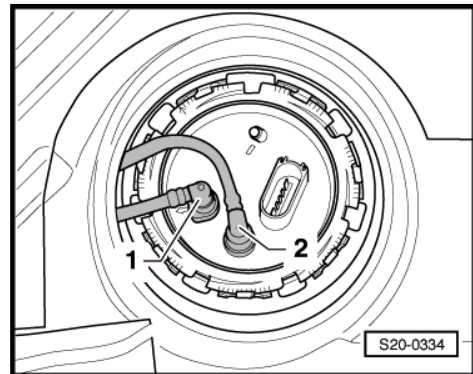

- Open lock ring with wrench -T30101- .



**Note**

- ◆ Take the fuel delivery unit out of the fuel tank in such a way that the electrical cables and the fuel hoses are not damaged and that the float arm of the sender for the fuel gauge display -G- is not bent.
- ◆ You must empty the old delivery unit before disposing of it if you wish to replace the fuel delivery unit.

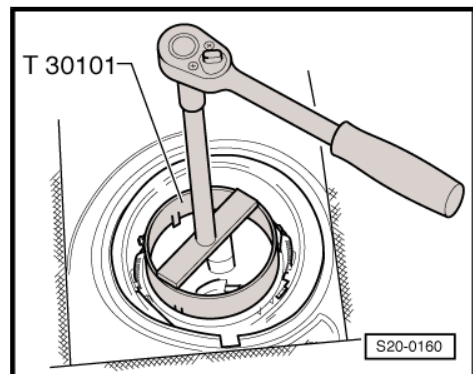

- Pull the fuel delivery unit out of the opening of the fuel tank.

**Install**

Installation occurs in reverse order. Pay attention to the following:

- Insert the new dry gasket ring into the opening of the fuel tank and moisten only from the inside with fuel for installing the closing flange.
- Insert the fuel delivery unit into the fuel tank in such a way that the float arm of the sender for the fuel gauge display -G- is not bent.
- Press the closing flange downwards, install the lock ring and connect the fuel lines.

**i** Note

- ◆ Pay attention to installed position of flange of fuel delivery unit: The peg -2- on the fuel delivery unit must be between the pegs -1- and -3-. The -arrow- shows the direction of travel.
- ◆ Tighten the lock ring to 110 Nm.
- ◆ Do not interchange the black feed line with the blue return-flow line (arrows on the flange of the fuel delivery unit).
- ◆ Make sure the line connections and the 5-pin plug fit tightly.
- ◆ After installing the fuel delivery unit, check whether the feed and return-flow lines are also clipped on the fuel tank.

- Clip on cover -4- with fuel pump control unit -J538- -1-. The arrow -2- on the cover points in direction of travel.

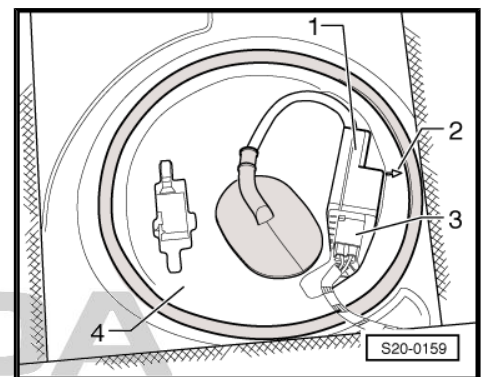
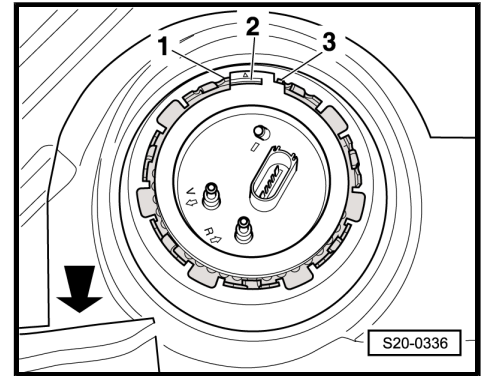

## 1.9 Removing and installing the sender for fuel gauge display -G-

### Removing

- Remove fuel delivery unit ⇒ [page 122](#) or ⇒ [page 122](#) .
- Unlock the catches -arrows- using a screwdriver and pull out the sender for fuel gauge display -G- towards the top.

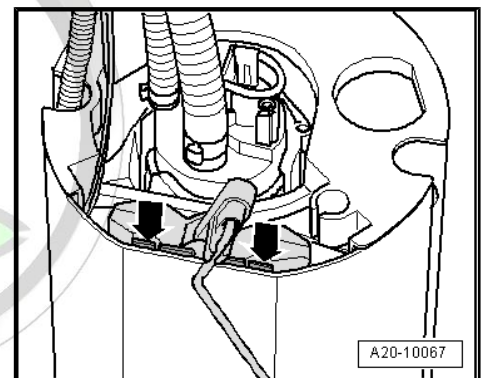

Protected by copyright. Copying for private or commercial purposes, in part or in whole, is not permitted unless authorised by ŠKODA AUTO A. S. ŠKODA AUTO A. S. does not guarantee or accept any liability with respect to the correctness of information in this document. Copyright by ŠKODA AUTO A. S. ©



- Unlatch and disconnect the plugs of the electrical cables -1- (brown), -2- (blue) and -3- (black).

#### Install

- Connect the wiring and check correct installation of the plug.
- Insert the sender for fuel gauge display -G- in the guide at the fuel delivery unit and press downwards until it latches into position.
- Install fuel delivery unit ⇒ [page 122](#) .

# ŠKODA

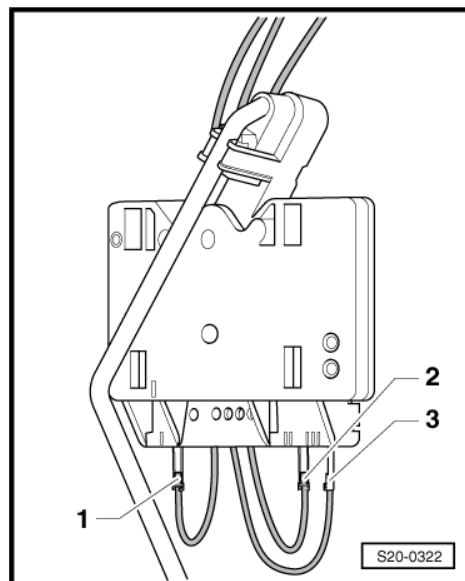

## 1.10 Testing fuel pump

### Special tools and workshop equipment required

- ◆ Key -T30101 (3087)-
- ◆ Pressure gauge , e.g. -V.A.G 1318- or pressure gauge , e.g. -VAS 6550-
- ◆ Adapter , e.g. -V.A.G 1318/11-
- ◆ Hose adapter , e.g. -V.A.G 1318/16-
- ◆ Adapter set , e.g. - V.A.G 1318/17A-
- ◆ Double connection piece , e.g. - V.A.G 1318/23-
- ◆ Remote control , e.g. -V.A.G 1348/3A- with adapter cable , e.g. -V.A.G 1348/3-3-
- ◆ Voltage tester , e. g. -V.A.G 1527 B-
- ◆ Measuring tool set , e.g. -V.A.G 1594 C-
- ◆ Multimeter , e.g. -V.A.G 1715-
- ◆ Adapter for measuring method/DSO (5-pin) , e.g. -VAS 5565-
- ◆ Vehicle diagnosis, measurement and information system - VAS 505X-
- ◆ Measuring glass



#### Note

- ◆ *The adapter set -V.A.G 1318/17A- replaces the adapter set -V.A.G 1318/17- .*
- ◆ *The figures shown in the description were not changed for this reason.*

Inspect proper operation and power supply ⇒ [page 129](#)

Check fuel pressure with pressure gauge -V.A.G 1318-  
⇒ [page 130](#)

Check fuel pressure with pressure gauge -VAS 6550-  
⇒ [page 131](#)

Check holding pressure with pressure gauge -V.A.G 1318 -  
⇒ [page 133](#)

Check holding pressure with pressure gauge -VAS 6550-  
⇒ [page 135](#)

Check fuel flow rate with pressure gauge -V.A.G 1318 -  
⇒ [page 136](#)

Check fuel flow rate with pressure gauge -VAS 6550-  
⇒ [page 139](#)

Check power consumption ⇒ [page 142](#)

### 1.10.1 Inspecting proper operation and power supply

#### Test conditions

- Battery voltage at least 11.5 V.
- Fuel pump fuse O.K. ⇒ Current flow diagrams, Electrical fault finding and Fitting locations.
- Fuel pump control unit -J538- O.K.

#### Test sequence



#### Note

*The function of the fuel pump is tested with the actuator diagnosis.*

- Connect vehicle diagnosis, measurement and information system -VAS 505X- .
- Switch on ignition.
- On the display press consecutively the buttons for „Vehicle self-diagnosis“, „01 - Engine electronics“ and „03 - Actuator diagnosis“.
- On the display press the right arrow button up to the actuator diagnosis of the fuel pump electronics.
- The fuel pump must now run slowly to the maximum speed.



#### Note

*The fuel pump runs very quietly.*

- Switch off ignition.

#### The fuel pump does not run:

- Remove rear seat bench with brackets ⇒ [Body Work](#) ⇒ [Rep.](#)  
gr. 72 .
- Remove floor covering under the rear seat bench.

ŠKODA

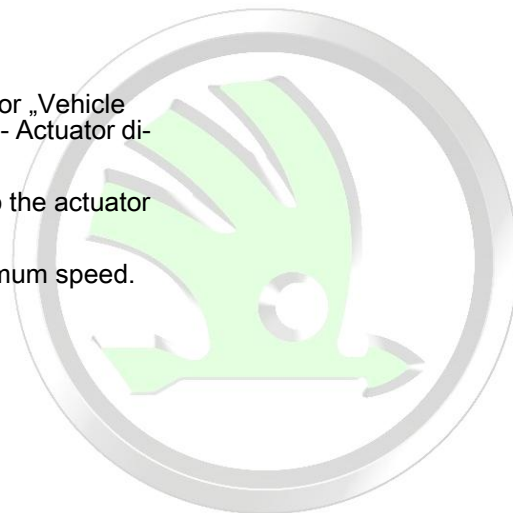

Protected by copyright. Copying for private or commercial purposes, in part or in whole, is not permitted without the written permission of ŠKODA AUTO A. S. ŠKODA AUTO A. S. does not guarantee or accept any liability with respect to the correctness of information in this document. Copyright by ŠKODA AUTO A. S. ©



- Disconnect plug -3- from fuel pump control unit -J538- .

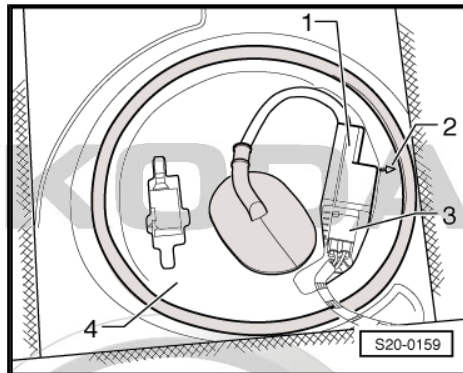

- Testing the voltage supply with the voltage tester -V.A.G 1527B- between contact -1- and -6-.

- The LED must light up.

The LED does not light up:

- Determine and remove open circuit in the wiring according to the current flow diagram → Current flow diagrams, Electrical fault finding and Fitting locations.

The LED lights up (power supply O.°K.):

- Remove fuel delivery unit ⇒ [page 122](#) .
- Check whether the electric wiring between the flange and fuel pump is connected.

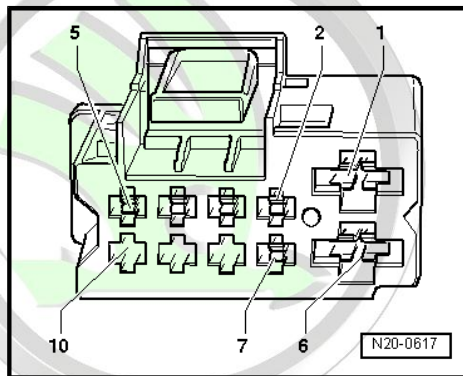

If there is no open circuit in the wiring:

- Fuel pump defective, replace the fuel delivery unit ⇒ [page 122](#) .

Protected by copyright. Copying for private or commercial purposes, in part or in whole, is not permitted without the express authorisation by ŠKODA AUTO A. S. ŠKODA AUTO A. S. does not guarantee or accept any liability with respect to the correctness of information in this document. Copyright by ŠKODA AUTO A. S. ©

### 1.10.2 Check fuel pressure with pressure gauge -V.A.G 1318-

- The function of the fuel pump was checked ⇒ [page 129](#) .



#### Note

- ◆ *Safety precautions when working on the fuel supply system* ⇒ [page 3](#) .
- ◆ *Rules of cleanliness when working on the fuel supply system* ⇒ [page 5](#) .
- Remove the fuel feed line -2- (press in the securing ring to the top) and catch the fuel which flows out with a cleaning cloth.

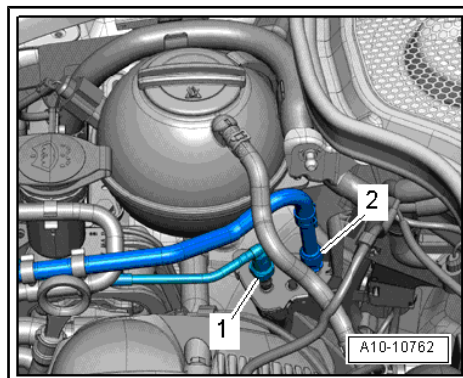

- Install the pressure gauge -V.A.G 1318 - with the adapter set -V.A.G 1318/17A- instead of the fuel feed line.
- Open shut-off cock of the pressure gauge. The lever then points in position -A-.
- Switch the ignition on and off so often until the fuel pressure on the pressure gauge does no longer rise.
- Read off fuel pressure on the pressure gauge.
- Specified value: 0,4 ... 0,7 MPa (4 ... 7.0 bar)

**If fuel line is o.k.:**

- Test holding pressure ⇒ [page 133](#) .

**If the specified pressure is exceeded:**

- Check the return line between the fuel filter and fuel pump for kinks and blockages.

**If no fault is found:**

- Pressure limiting valve in the fuel filter defective, replace the fuel filter.

**If the measurement is less than the specification:**

- Check the fuel pressure before the fuel filter. For this step connect the pressure gauge -V.A.G 1318- with the adapter set -V.A.G 1318/17A- between the fuel filter and the fuel feed line.
- Open shut-off cock of the pressure gauge. Lever points in direction of flow.
- Start engine and run in idle.

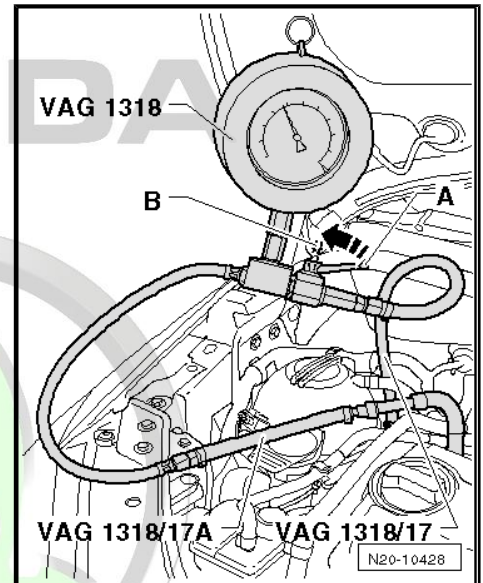

 **Caution**

*The shut-off cock must only be closed slowly. At a fuel pressure of 0.8 MPa (8 bar), the shut-off cock must be immediately opened, in order to avoid a damage of the pressure gauge.*

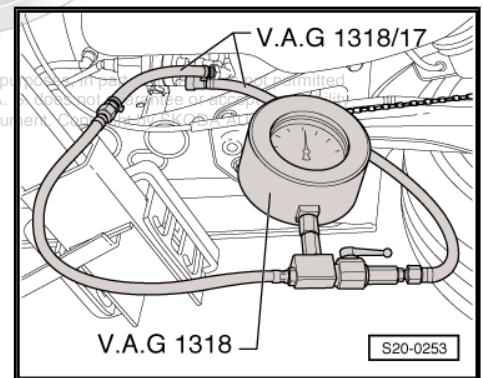

- Slowly close the shutoff cock of the pressure measuring device. The pressure must rise to at least 0,6 MPa (6,0 bar). If the 0,6 MPa (6,0 bar) is reached, immediately open the shut-off cock again!

**If the pressure has risen:**

- Fuel pump O.K., pressure limiting valve in the fuel filter defective, replace the fuel filter.

**If the pressure does not rise:**

- Fuel pump defective, replace the fuel delivery unit ⇒ [page 122](#) .

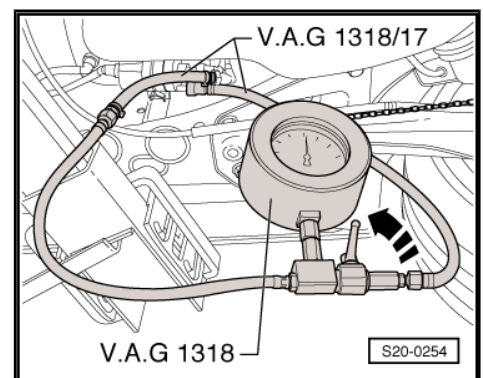

### 1.10.3 Check fuel pressure with pressure gauge -VAS 6550-

- The function of the fuel pump was checked ⇒ [page 129](#) .



**Note**

- ◆ *Safety precautions when working on the fuel supply system*  
⇒ [page 3](#) .
- ◆ *Rules of cleanliness when working on the fuel supply system*  
⇒ [page 5](#) .
- Remove the fuel feed line -2- (press in the securing ring to the top) and catch the fuel which flows out with a cleaning cloth.

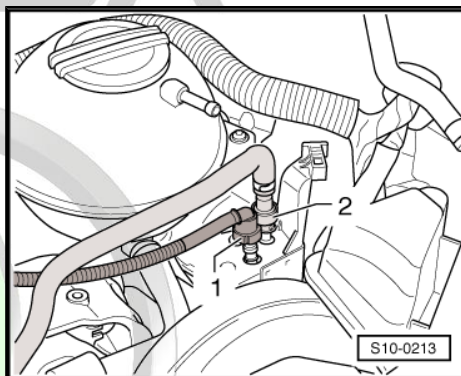

- Connect the pressure gauge -VAS 6550- with adapters -VAS 6550/1- and -VAS 6550/2- to the fuel feed line.
- Make sure that the discharge cock is closed and the shut-off cocks are opened.
- Switch the ignition on and off so often until the fuel pressure on the pressure gauge does no longer rise.
- Read off fuel pressure on the pressure gauge.
- Specified value: 0,4 ... 0,7 MPa (4 ... 7.0 bar)

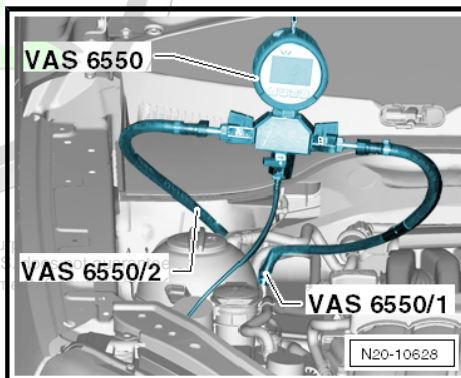

**If fuel line is o.k.:**

- Test holding pressure ⇒ [page 133](#) .

**If the specified pressure is exceeded:**

- Check the return line between the fuel filter and fuel pump for kinks and blockages.

**If no fault is found:**

- Pressure limiting valve in the fuel filter defective, replace the fuel filter.

**If the measurement is less than the specification:**

- Check the fuel pressure before the fuel filter, to do so proceed as follows:
- Disconnect fuel feed line -arrow- at fuel filter.

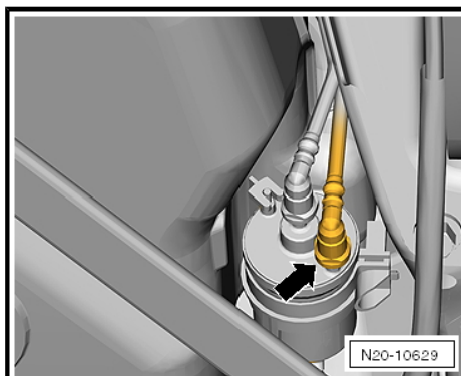



- Connect the pressure gauge -VAS 6550- with the adapter -VAS 6550/1- and -VAS 6550/2- between the fuel filter and the fuel feed line.
- Make sure that the discharge cock is closed and the shut-off cocks are opened.
- Start engine and run in idle.

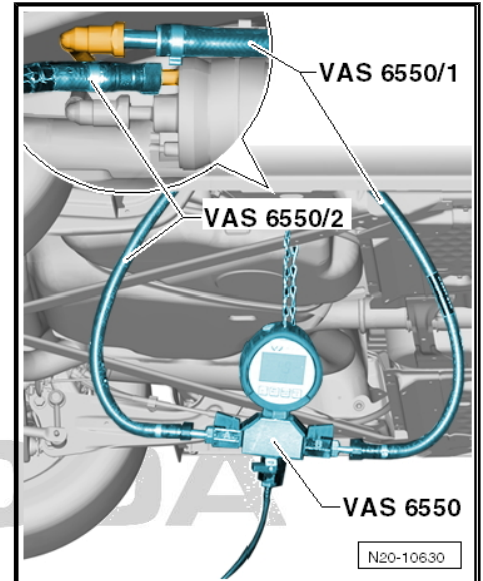

- Slowly close the shutoff cock -A-.
- The pressure must rise to at least 0.7 MPa (7.0 bar).
- If the 0.7 MPa (7.0 bar) is reached, immediately open the shut-off cock again!

If the pressure has risen:

- Fuel pump O.K., pressure limiting valve in the fuel filter defective, replace the fuel filter.

If the pressure does not rise:

- Fuel pump defective, replace fuel delivery unit => [page 122](#) .

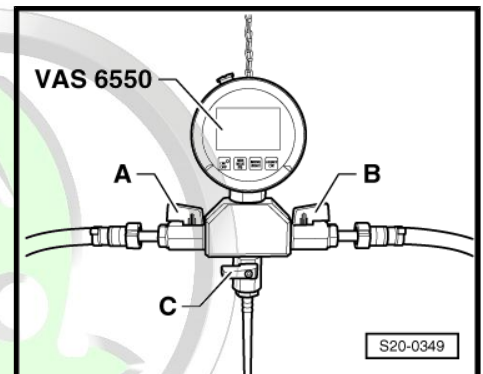

#### 1.10.4 Checking holding pressure with pressure gauge -V.A.G 1318-

- Fuel pressure O.K. and pressure gauge -V.A.G 1318- connected in the engine compartment => [page 130](#).

#### Note

- ◆ *Safety precautions when working on the fuel supply system => [page 3](#) .*
- ◆ *Rules of cleanliness when working on the fuel supply system => [page 5](#) .*

- Switch the ignition on and off so often until the fuel pressure on the pressure gauge does no longer rise.
- Read off fuel pressure on the pressure gauge.
- Specified value: 0,4 ... 0,7 MPa (4 ... 7.0 bar)
- Observe pressure drop at pressure gauge.
- The pressure must not drop below 0,3 MPa (3,0 bar) after 10 minutes.

**If the pressure still drops:**

- Switch the ignition on and off so often until the fuel pressure on the pressure gauge does no longer rise.

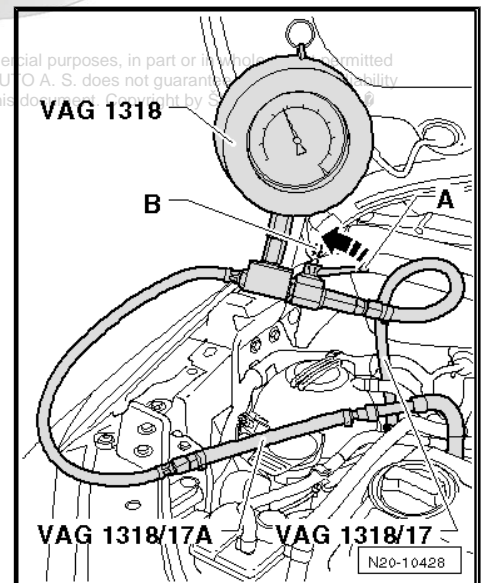



- Immediately close the shutoff cock of the pressure measuring device. The lever then points in the position -B-.

**If the pressure again drops:**

- Check the low pressure pipe to the high pressure pump for tightness.

If no fault is found:

- Replace high pressure pump ⇒ [page 174](#) .

**Now the pressure does no longer drop:**

- Check the fuel line to the fuel filter for tightness.

If the fuel line is not found to be faulty:

- Check the non-return valve in the fuel delivery unit. For this step connect the pressure measuring device -V.A.G 1318- with the adapter -V.A.G 1318/17A- between the fuel filter and the fuel feed line.
- Open shut-off cock of the pressure gauge. Lever points in direction of flow.
- Switch the ignition on and off so often until the fuel pressure on the pressure gauge does no longer rise.
- Read off fuel pressure on the pressure gauge.
- Specified value: 0,4 ... 0,7 MPa (4 ... 7.0 bar)

- Immediately close the shut-off cock of the pressure measuring device after the pressure has built up.
- Observe pressure drop at pressure gauge.
- The pressure must not drop below 0,3 MPa (3,0 bar) after 10 minutes.

If the pressure drops:

- Non-return valve in the fuel pump faulty, replace fuel delivery unit ⇒ [page 122](#) .

If the pressure does not drop:

- Pressure limiting valve in the fuel filter defective, replace the fuel filter.

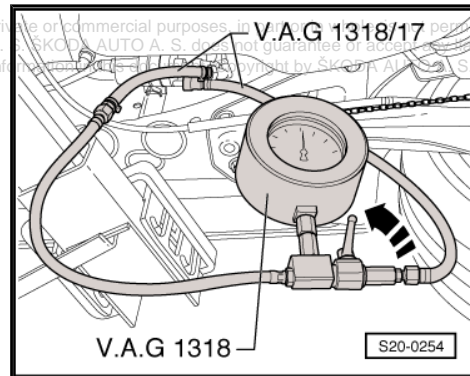
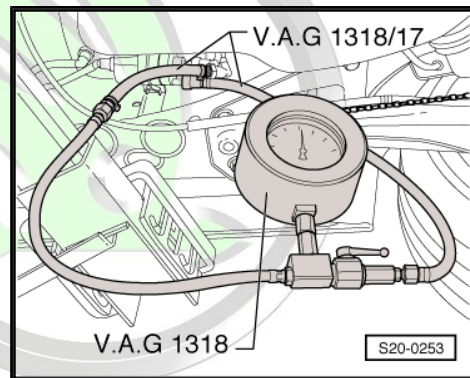
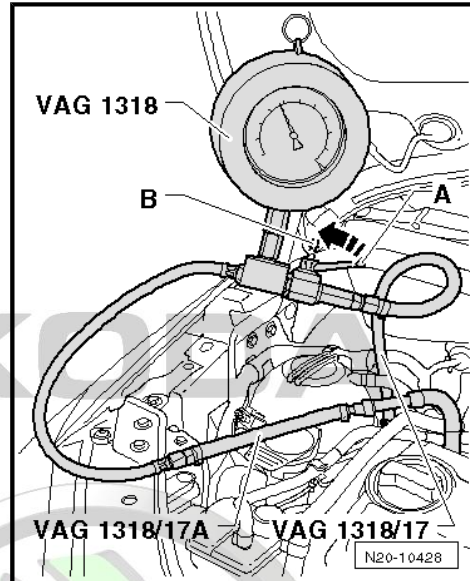

### 1.10.5 Checking holding pressure with pressure gauge -VAS 6550-

- Fuel pressure O.K. and pressure gauge -VAS 6550- connected in the engine compartment ⇒ [page 131](#) .

#### Note

- ◆ *Safety precautions when working on the fuel supply system* ⇒ [page 3](#) .
- ◆ *Rules of cleanliness when working on the fuel supply system* ⇒ [page 5](#) .
- Switch the ignition on and off so often until the fuel pressure on the pressure gauge does no longer rise.
- Read off fuel pressure on the pressure gauge.
- Specified value: 0,4 ... 0,7 MPa (4 ... 7.0 bar)
- Observe pressure drop at pressure gauge.
- The pressure must not drop below 0,3 MPa (3,0 bar) after 10 minutes.

#### If the pressure still drops:

- Switch the ignition on and off so often until the fuel pressure on the pressure gauge does no longer rise.
- Immediately close the shut-off cock -B- of the pressure gauge after the pressure has built up. The lever points at right angles in the direction of flow.

#### Now the pressure does no longer drop:

#### Note

*Search for leakage on the engine side. Repeat the holding pressure test. This time, close the shut-off cock -A- in order to determine if a leak is indeed present on the engine side.*

- Check the low-pressure line to the high pressure pump for tightness.

If no fault is found:

- Replace high pressure pump ⇒ [page 174](#) .

#### If the pressure again drops:

Search for leakage on the fuel tank side, to do so proceed in the following manner:

- Check the fuel line to the fuel filter for tightness.

If the fuel line is not found to be faulty:

- Check the pressure holding valve in the fuel delivery unit. To do so proceed in the following manner:

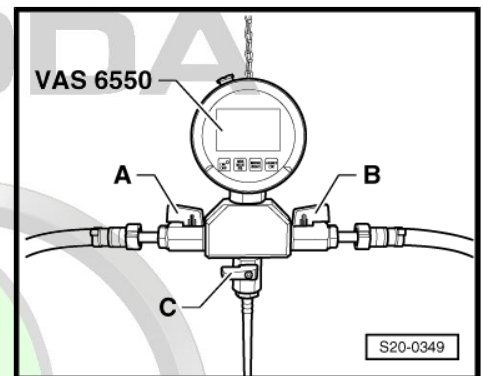
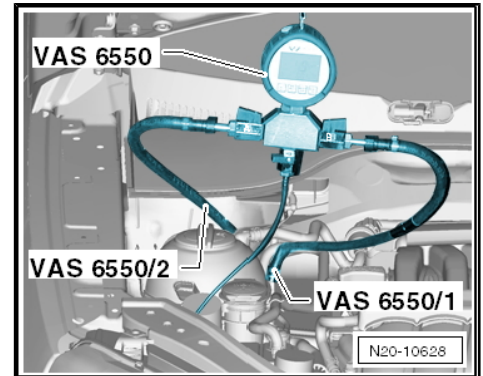



- Disconnect fuel feed line -arrow- at fuel filter.

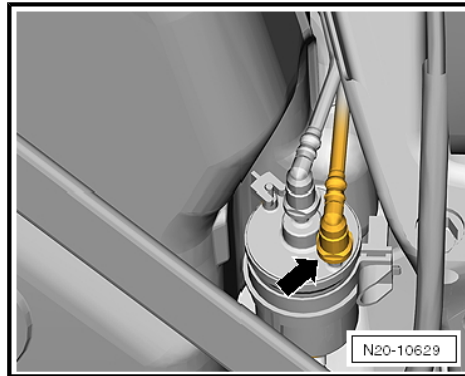

- Connect the pressure gauge -VAS 6550- with the adapter -VAS 6550/1- and -VAS 6550/2- between the fuel filter and the fuel feed line.
- Make sure that the discharge cock is closed and the shut-off cocks are opened.
- Switch the ignition on and off so often until the fuel pressure on the pressure gauge does no longer rise.
- Read off fuel pressure on the pressure gauge.
- Specified value: 0.58 ... 0.70 MPa (5.8 ... 7.0 bar)

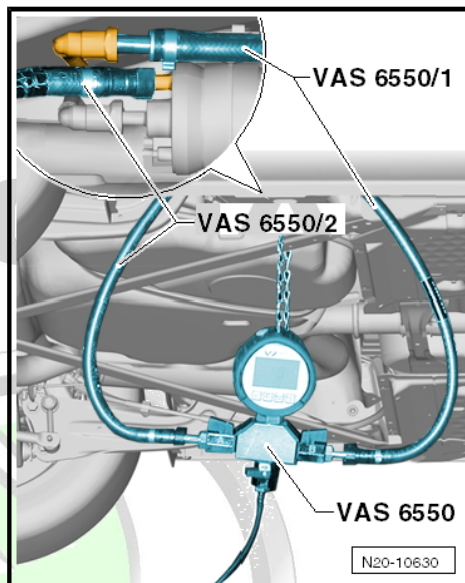

- After the pressure has built up, close the shut-off cock -A-.
- Observe pressure drop at pressure gauge.
- The pressure must not drop below 0,3 MPa (3,0 bar) after 10 minutes.

If the pressure drops:

- Non-return valve in the fuel pump faulty, replace fuel delivery unit ⇒ [page 122](#) .

If the pressure does not drop:

- Pressure limiting valve in the fuel filter defective, replace the fuel filter.

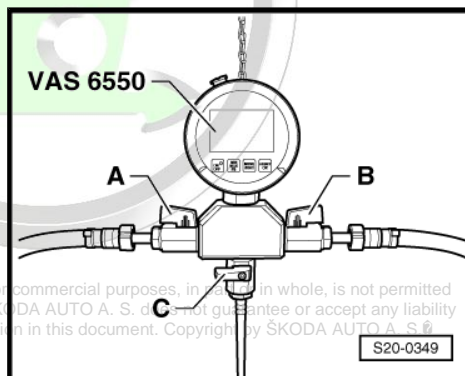

### 1.10.6 Checking fuel flow rate with pressure gauge -V.A.G 1318-



Note

- ◆ *Safety precautions when working on the fuel supply system* ⇒ [page 3](#) .
- ◆ *Rules of cleanliness when working on the fuel supply system* ⇒ [page 5](#) .
- Switch off the ignition and all electrical components and take out the ignition key.

- Remove rear seat bench with brackets ⇒ Body Work ⇒ Rep. gr. 72 .
- Remove floor covering under the rear seat bench.
- Disconnect plug -3- from fuel pump control unit -J538- -1-.

**Vehicles with auxiliary heating.**

- Unplug the 2-pin plug of the dosing pump -V54- .

**Continued for all vehicles**

- Unclip the cover -4- with the fuel pump control unit -J538- -1-.

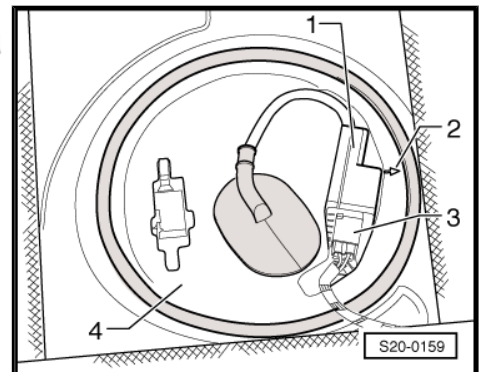

- First of all check the plug -1- for correct fit. To do so, pull on the plug connection without pressing the catch. If the plug connection was not correctly positioned, this could cause a fault.
- Now unplug the plug -1-.
- Check the contacts at the plug and at the fuel delivery unit for damage.

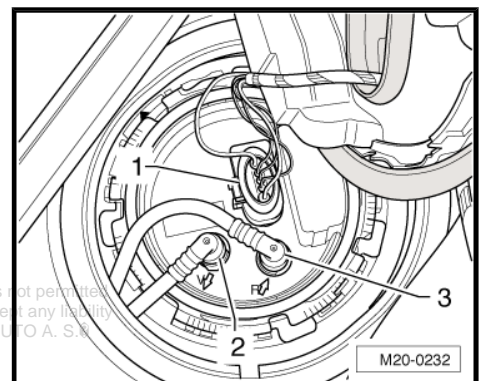

Protected by copyright. Copying for private or commercial purposes, in part or in whole, is not permitted unless authorised by ŠKODA AUTO A. S. ŠKODA AUTO A. S. does not guarantee or accept any liability with respect to the correctness of information in this document. Copyright by ŠKODA AUTO A. S.

- Connect the adapter for measuring method/DSO (5-pin) -VAS 5565- to the plug and to the fuel delivery unit.
- Connect the remote control -V.A.G 1348/3A- to the adapter -VAS 5565- and to battery positive (+).

**Note**

*This step is only intended to ensure that the fuel delivery unit runs when the engine is switched off.*

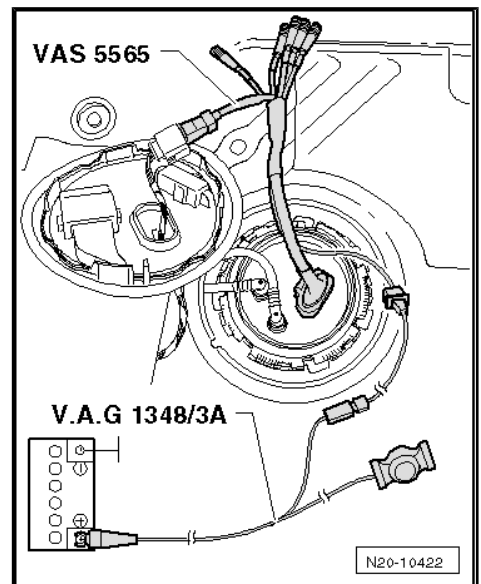



- Remove the fuel feed line -2- (press in the securing ring to the top) and catch the fuel which flows out with a cleaning cloth.

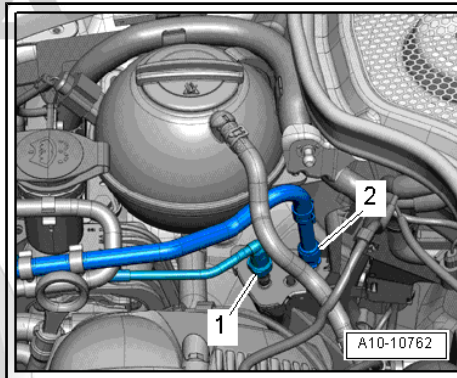

- Connect the pressure gauge -V.A.G 1318- with the double connection piece -V.A.G 1318/23- and the adapter set -V.A.G 1318/17A- to the fuel feed line.
- Fit the hose adapter -V.A.G 1318/16- onto the adapter -V.A.G 1318/11- of the pressure measuring device and hold it in a measuring vessel.
- Close the shut-off cock of the pressure measuring device. The lever then points in the position -B-.

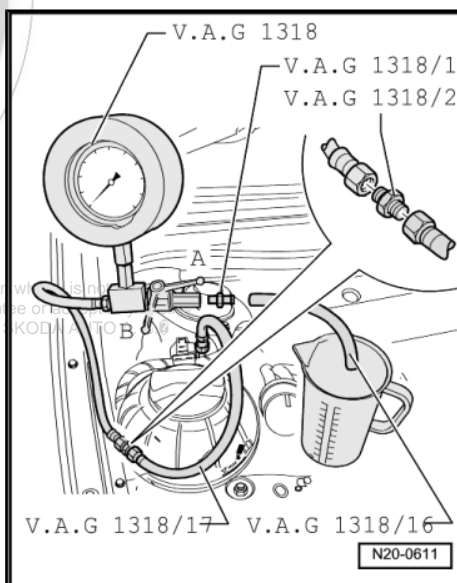

**WARNING**

*Danger of liquid spraying out when opening the shut-off valve. Wear safety goggles and safety clothing, in order to avoid injuries and skin contact with fuel. Hold the container in front of the free connection to the pressure gauge.*

- Open shut-off cock of the pressure gauge. The lever then points in the direction of flow -A-.
- Activate remote control -V.A.G 1348/3A- . While doing so, slowly close the shut-off cock until the pressure gauge displays 0.4 MPa (4 bar) overpressure. Now do not make any further changes to the position of the shut-off cock.
- Empty measuring glass.
- The fuel flow rate of the fuel delivery unit is dependent on the battery voltage. For this reason, additionally connect the multimeter -V.A.G 1715- to the outgoing circuits -1 and 5- of the adapter for measuring method/DSO (5-pin) -VAS 5565- .
- Activate remote control for 30 seconds while measuring the battery voltage.

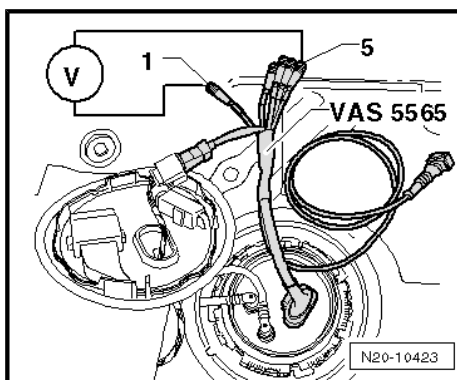



- Compare the fuel rate with the specified value.

\*) minimum flow rate 1 cm<sup>3</sup>/30 s

\*\*) Voltage at fuel delivery unit when engine not running and delivery unit operating (approx. 2 volts less than battery voltage)

Read out examples:

During the test a voltage of 12.5 V was measured on the battery. As the voltage on the fuel pump is approximately 2V less than the battery voltage, a minimum flow rate of 580 cm<sup>3</sup>/30 s is obtained.

If the minimum delivery volume is not reached:

- Check the fuel lines for possible restrictions (kinks) or blocking.

If no fault is found:

- Disconnect the feed hose -1- from the fuel filter inlet.
- Connect pressure gauge -V.A.G 1318- with the adapter set -V.A.G 1318/17A- to the hose.
- Repeat fuel flow rate test.

If the minimum flow rate is now reached:

- Replace fuel filter.

If the minimum flow rate is again not reached:

- Remove fuel delivery unit and inspect the filter strainer for soiling.

If you have still not found any fault up to this stage:

- Replace fuel delivery unit ⇒ [page 122](#) .

If the required fuel delivery volume has been achieved, but a fault is still suspected in the fuel supply system (e.g. intermittent breakdown of the fuel supply):

- Check power consumption of the fuel pump ⇒ [page 142](#) .

### 1.10.7 Checking fuel flow rate with pressure gauge -VAS 6550-

- Switch off the ignition and all electrical components and take out the ignition key.
- Removing rear seat bench ⇒ Body Work ⇒ Rep. gr. 72 .
- Unclip the cover -4- with the fuel pump control unit -J538-1-.

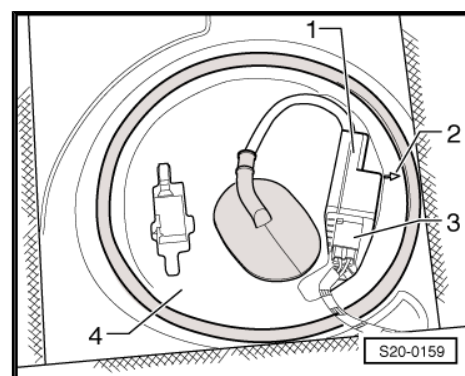
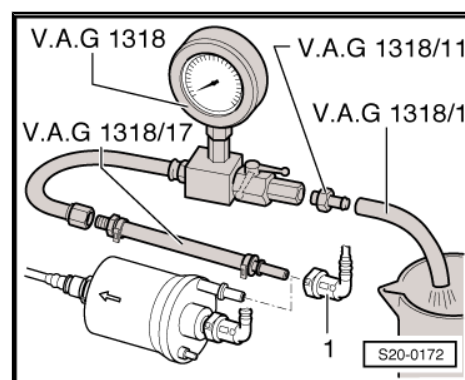
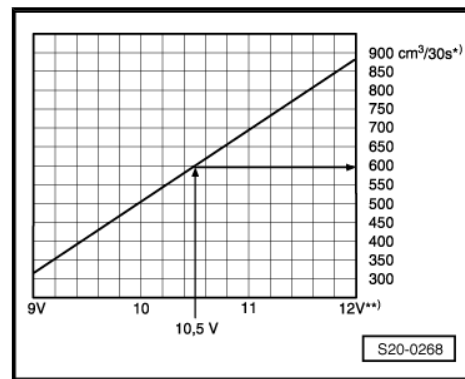



- First of all check the plug -1- for correct fit. To do so, pull on the plug connection without pressing the catch. If the plug connection was not correctly positioned, this could cause a fault.
- Now unplug the plug -1-.
- Check the contacts at the plug and at the fuel delivery unit for damage.

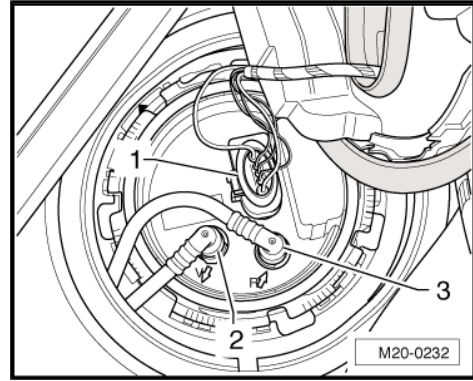

- Connect the adapter for measuring method/DSO (5-pin) -VAS 5565- to the plug and to the fuel delivery unit.
- Connect the remote control -V.A.G 1348/3A- to the adapter -VAS 5565- and to battery positive (+).

**i** Note

*This step is only intended to ensure that the fuel delivery unit runs when the engine is switched off.*

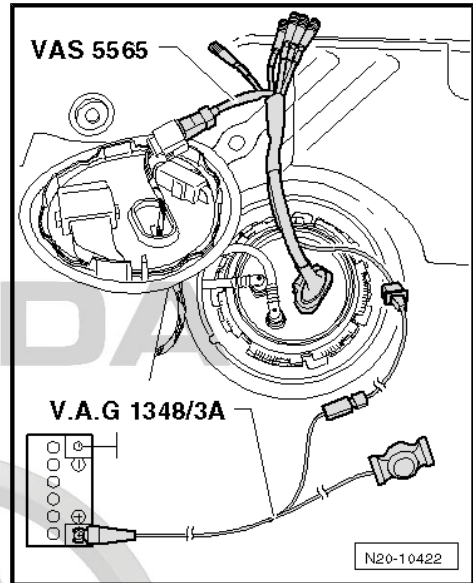

- Disconnect the feed line -2- (press in the securing ring to the top) and catch the fuel which flows out with a cleaning cloth.

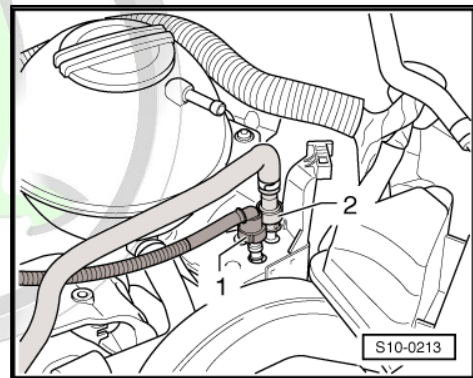

Protected by copyright. Copying for private or commercial purposes, in part or in whole, is not permitted unless authorised by ŠKODA AUTO A. S. ŠKODA AUTO A. S. does not guarantee or accept any liability with respect to the correctness of information in this document. Copyright by ŠKODA AUTO A. S. ©

- Connect the pressure gauge -VAS 6550- with the adapter -VAS 6550/2- to the fuel feed line. Hold the adapter -VAS 6550/1- in a measuring vessel.
- Make sure that the discharge cock is closed and the shut-off cocks are opened.

**! WARNING**

*Danger of liquid spraying out when opening the shut-off valve. Wear safety goggles and safety clothing, in order to avoid injuries and skin contact with fuel. Hold the container in front of the free connection to the pressure gauge.*

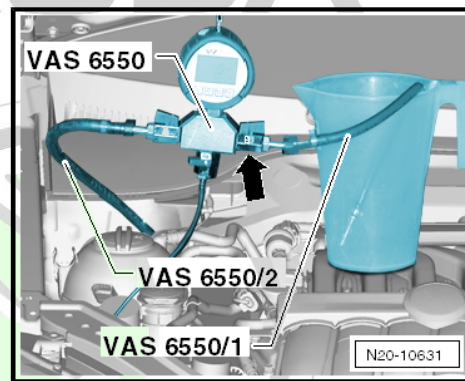

- Activate remote control -V.A.G 1348/3A - . While doing this, slowly close the shut-off cock -arrow- until the pressure gauge displays 0.4 MPa (4 bar) overpressure. Now do not make any further changes to the position of the shut-off cock.
- Empty measuring glass.
- The fuel flow rate of the fuel delivery unit is dependent on the battery voltage. For this reason, additionally connect the multimeter -V.A.G 1715- to the outgoing circuits -1 and 5- of the adapter for measuring method/DSO (5-pin) -VAS 5565- .
- Activate remote control for 30 seconds while measuring the battery voltage.

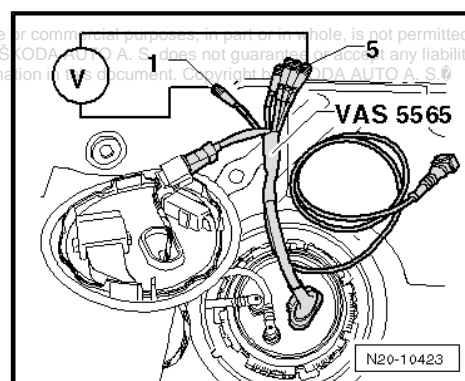

- Compare the fuel rate with the specified value.

\*) minimum flow rate 1 cm<sup>3</sup>/30 s

\*\*\*) Voltage at the fuel pump when engine not running and delivery unit operating.

Read out examples:

During the test a voltage of 10.5 V was measured. Thus a minimum flow rate of 580 cm<sup>3</sup>/30 s is obtained.

If the minimum delivery volume is not reached:

- Check the fuel lines for possible restrictions (kinks) or blocking.

If no fault is found:

- Take cap off fuel filler neck and repeat the test.

If the fuel flow rate is now reached:

- Check the ventilation of the fuel tank.

If the minimum flow rate is again not reached:

- Check the fuel filter, to do so proceed as follows:

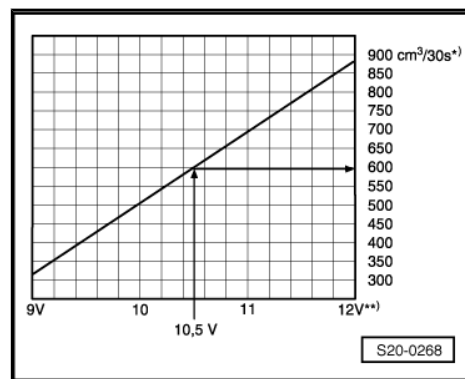



- Disconnect fuel feed line -arrow- at fuel filter.

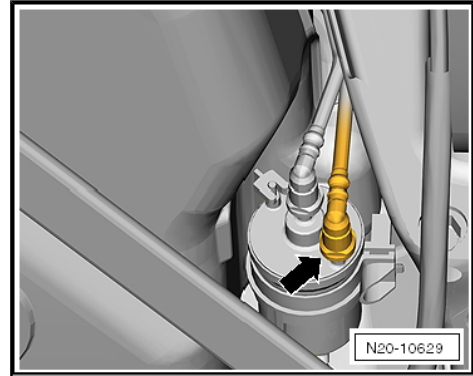

- Connect the pressure gauge -VAS 6550- with the adapter -VAS 6550/1- to the fuel feed line. Hold the adapter -VAS 6550/2- in a measuring vessel.
- Make sure that the discharge cock is closed and the shut-off cocks are opened.
- Repeat fuel flow rate test.

If the minimum flow rate is now reached:

- Replace fuel filter.

If the minimum flow rate is again not reached:

- Remove fuel delivery unit and inspect filter strainer for soiling.

If you have still not found any fault up to this stage:

- Replace fuel delivery unit ⇒ [page 122](#) .

If the required fuel delivery volume has been achieved, but a fault is still suspected in the fuel supply system (e.g. intermittent break-down of the fuel supply).

- Check power consumption of the fuel pump ⇒ [page 142](#) .

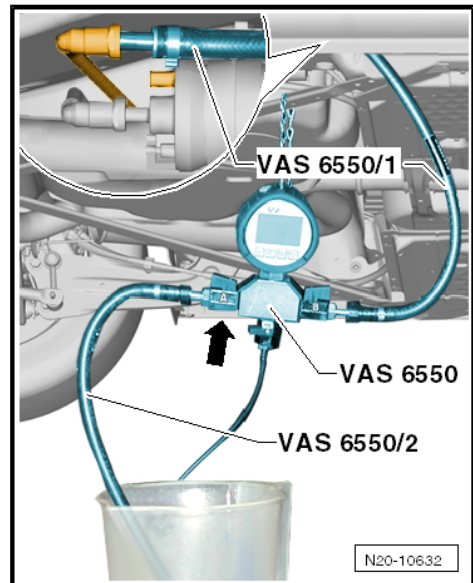

### 1.10.8 Check power consumption

- Remove rear seat bench with brackets ⇒ Body Work ⇒ Rep. gr. 72 .

- Remove floor covering under the rear seat bench.

- Unclip the cover -4- with the fuel pump control unit -J538-1-.

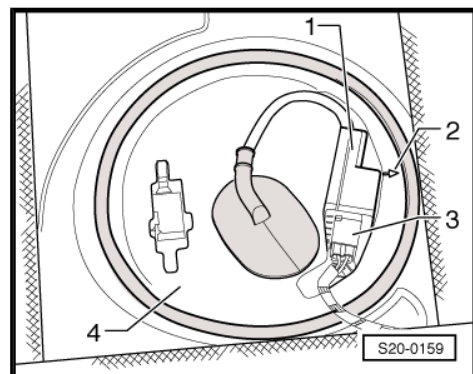



- Connect the current probe -A- of the vehicle diagnosis, measurement and information system -VAS 505X- on the line -B- to contact 1 of the 5-pin plug.

If the current probe cannot be connected on the line -B- to contact 1 of the 5-pin plug because of the length of the insulation:

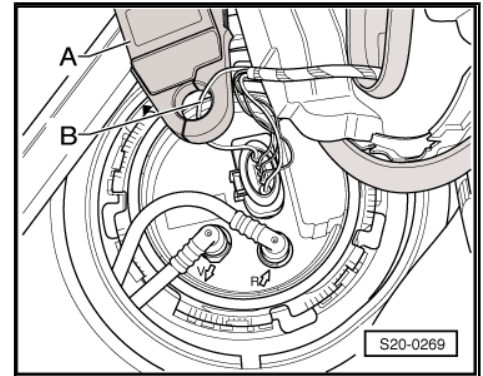

- Connect the adapter for measuring method/DSO (5-pin) -VAS 5565- to the plug and to the fuel delivery unit.
- Connect the current probe -A- to the red cable - with the lettering „current probe“ - of the adapter for measuring method/ DSO (5-pin) -VAS 5565- .

Continued for all

- Start engine and run in idle.
- Measure voltage consumption of the fuel pump.

Specified value: max. 9 A

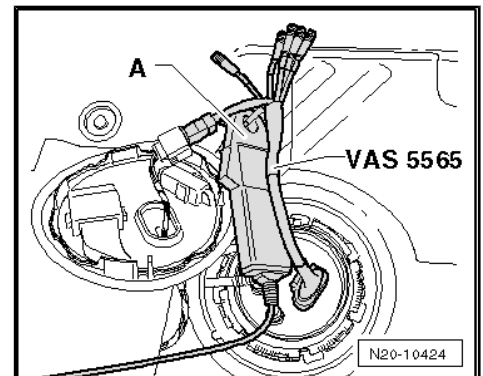

Note

If the fault in the fuel supply system is intermittent then tests can be undertaken during a test drive but then two people are required for this.

If the specified current uptake is exceeded:

- Fuel pump defective, replace the fuel delivery unit  
⇒ [page 122](#) .

## 1.11 Removing and installing fuel gauge sender -2- -G169- for vehicles manufactured up to 06.10

Special tools and workshop equipment required

- ◆ Key -T30101 (3087)-
- The fuel tank must not be more than  $\frac{1}{2}$  full.



Note

Protected by copyright. Copying for private or commercial purposes, in part or in whole, is not permitted unless authorised by ŠKODA AUTO A. S. ŠKODA AUTO A. S. does not guarantee or accept any liability in respect to the correctness of information in this document. Copyright by ŠKODA AUTO A. S. ©

- ◆ If necessary, extract fuel from the fuel tank ⇒ [page 115](#) .
- ◆ Safety precautions when working on the fuel supply system ⇒ [page 3](#) .
- ◆ Rules of cleanliness when working on the fuel supply system ⇒ [page 5](#) .
- ◆ Make sure that the float arm of the fuel gauge sender -2- -G169- is not bent.



### Removing

- Switch off all electrical components and withdraw key from ignition lock.
- Remove rear seat bench with brackets ⇒ Body Work ⇒ Rep. gr. 72 .
- Remove floor covering under the rear seat bench.
- Remove the left cover in direction of travel from the sender for the fuel gauge display -2- -G169- .
- Disconnect the plug connection.
- Open lock ring with wrench -T30101- .

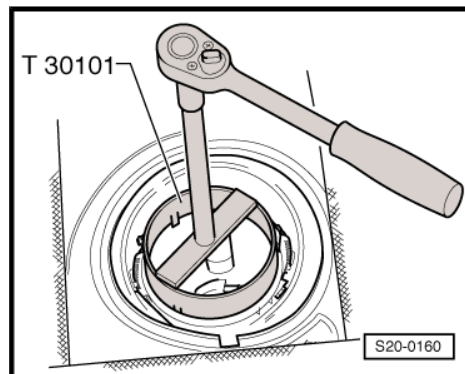
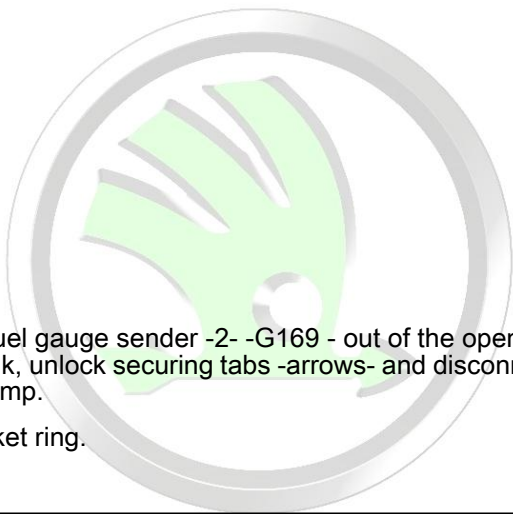

- Slightly pull fuel gauge sender -2- -G169 - out of the opening of the fuel tank, unlock securing tabs -arrows- and disconnect suction jet pump.
- Remove gasket ring.

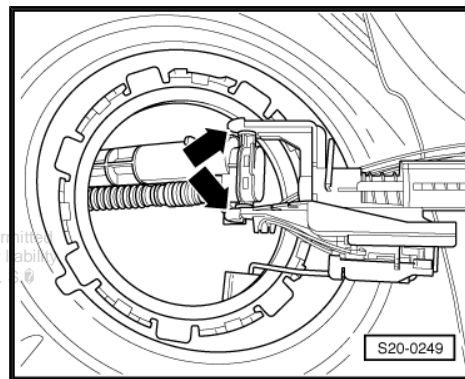

### Install



**Caution**

*When installing do not bend the float arm of the fuel gauge sender -2- -G169 - .*

- Insert the fuel gauge sender 2 -G169 - into the fuel tank.
- Position the suction jet pump in the fuel tank onto the sender. The catches must click audibly.
- Insert new dry gasket ring for the flange into the opening of the fuel tank and only now moisten the inside (position of the flange) with fuel.
- Pay attention to the fitting location of the fuel gauge sender -2- -G169- ⇒ [page 112](#) .
- Check correct seating of the gasket ring.
- Tighten lock ring with wrench for union nut -T30101- .  
Tightening torque: 110 Nm
- Mount the plug connection.
- Install cover.
- Insert the floor covering under the rear seat bench.
- Install rear seat bench with brackets ⇒ Body Work ⇒ Rep. gr. 72 .

## 1.12 Removing and installing suction jet pump for vehicles manufactured up to 06.10

### Note

- ◆ The fuel tank consists of a left and right chamber. In order to pump the fuel out of the left chamber -3- of the fuel tank into the right chamber to the housing of the delivery unit -2-, a suction jet pump -1- is required.
- ◆ The version of the fuel tank requires that the fuel is pumped from the area of the fuel gauge sender -2- -G169- with a suction jet pump to the fuel delivery unit.
- ◆ A check is only to be carried out, if the engine stops because of fuel shortage, although the fuel gauge still indicates a fuel tank which is  $\frac{1}{4}$  full.

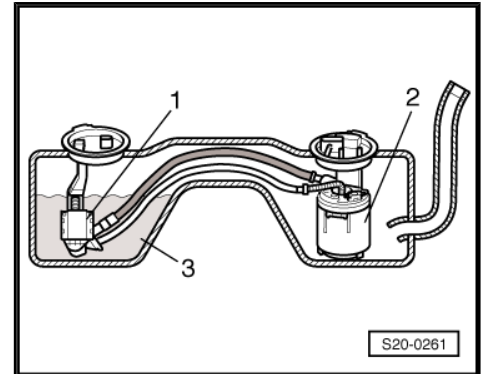

### Work procedure

- Remove fuel delivery unit ⇒ [page 122](#) .
- Remove fuel gauge sender -2- -G169- ⇒ [page 143](#) .
- Now the suction jet pump can be pulled out from the side of the fuel gauge sender -2- -G169- (on left in direction of travel).
- Check if the fuel lines are firmly connected to the suction jet pump and are not damaged.
- Check the suction jet pump additionally for possible contamination.



Protected by copyright. Copying for private or commercial purposes, in part or in whole, is not permitted unless authorised by ŠKODA AUTO A. S. ŠKODA AUTO A. S. does not guarantee or accept any liability with respect to the correctness of information in this document. Copyright by ŠKODA AUTO A. S. ©



## 2 Electronic Engine Power Control (Electronic throttle)

### 2.1 Accelerator pedal module - Summary of components

#### 1 - Connector

- black, 6 pin

#### 2 - Accelerator pedal position sender -G79- with accelerator pedal position sender 2 -G185-

- not adjustable
- the sender transmits the driver's instructions to the engine control unit
- A- openings for the release tool
- removing and installing ⇒ [page 146](#)
- when replacing, the engine control unit must be adapted ⇒ Vehicle diagnostic, testing and information system VAS 5051 on vehicles with automatic gearbox

#### 3 - 10 Nm

#### 4 - Cap

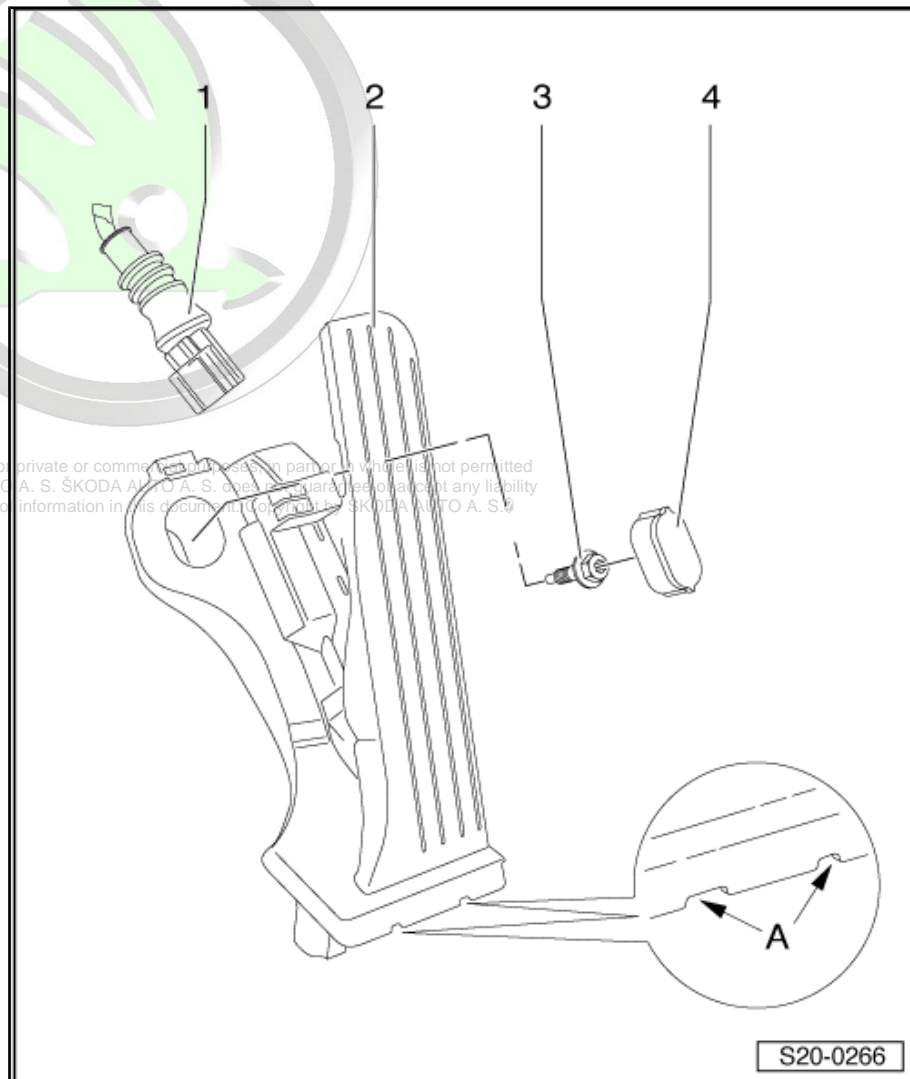

### 2.2 Removing and installing accelerator pedal module

#### Special tools and workshop equipment required

- ◆ Release tool -T10238- (for left-hand drive vehicle)
- ◆ Release tool -T10240- (for right-hand drive vehicle)



## Removing

- Remove steering column cover -arrows-.
- Lever out the cap ( ⇒ [page 146](#) , Pos. 4) with a screwdriver.
- Release fixing screw ( ⇒ [page 146](#) , Pos. 3).

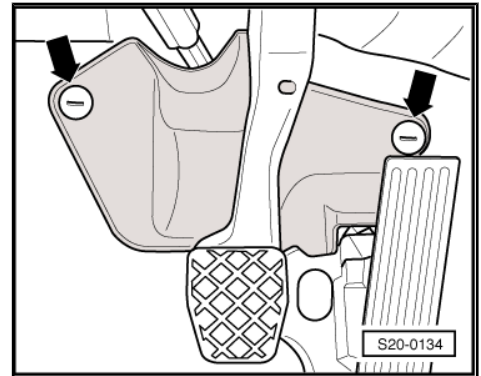

- Push the release tool -T10238- (for right-hand drive vehicles release tool -T10240 -) as shown up to the stop into the provided openings and remove the accelerator pedal module.
- Disconnect connector at accelerator pedal module ⇒ [page 148](#) .

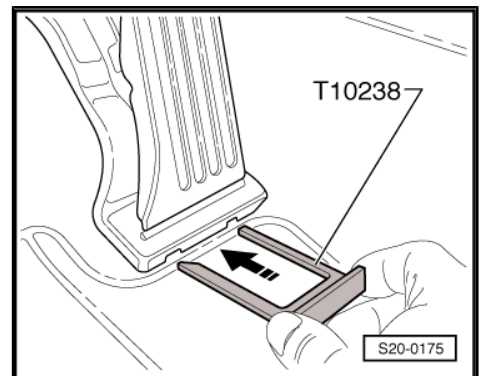

## Install

- Fit the plug -2- onto the accelerator pedal module -5- ⇒ [page 148](#) .  
 The plug must lock audibly.
- Push accelerator pedal module onto the fixing bolts -6-.
- Insert centering pin -7- in the hole in the vehicle floor.
- Fasten accelerator pedal module with screw -3- (10 Nm) and fit on cap -4-.
- Re-install steering column cover.
- If the accelerator pedal module was replaced, an adaptation of the engine control unit has to be performed on vehicles with automatic gearbox ⇒ Vehicle diagnostic, testing and information system VAS 5051.

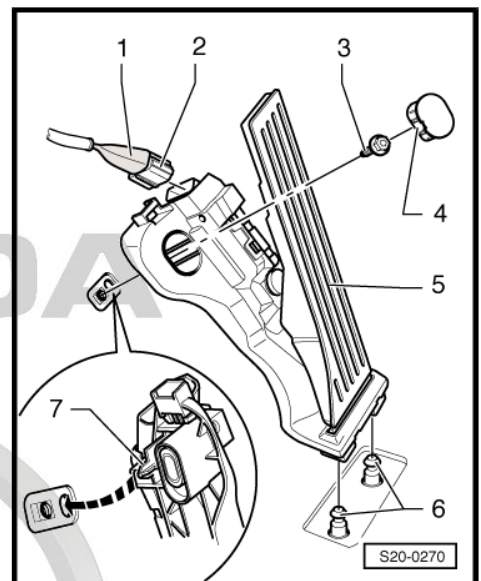

## 2.2.1 Disconnect connector for accelerator pedal module and fit on

### Note

The plugs for the accelerator pedal module which are inserted, must be disconnected and fit on in a different manner.

#### Disconnect connector 1K0 973 706

- Slightly press the piston slide valve -A- (grey) in -direction of arrow 1- and push it up to the stop in -direction of arrow 2-.
- Hold the piston slide valve in this position and disconnect the socket housing -B- towards the top in -direction of arrow 3-.

The piston slide valve -A- remains in the bottom position.

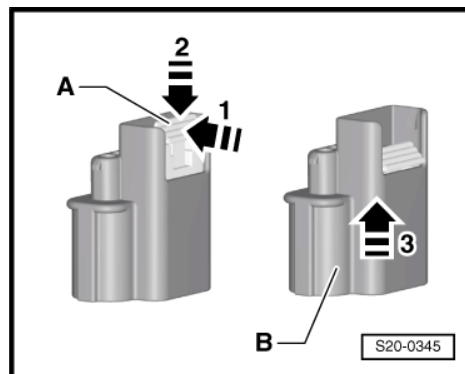

#### Fit on connector 1K0 973 706

- Push the socket housing -B- down in -direction of arrow- until the housing can be heard to lock in place.
- The piston slide valve -A- moves automatically upwards.
- For safety reasons, check the connector for secure catch by tightening it in the opposite direction.

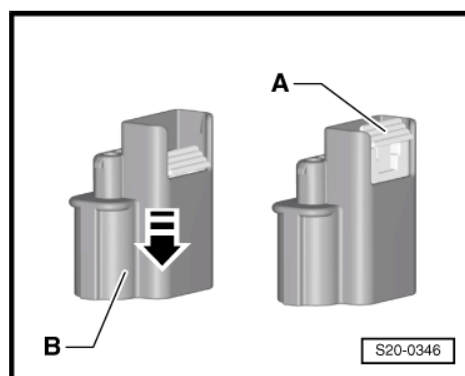

#### Disconnect connector 8K0 973 706

- Pull the piston slide valve -A- (red) upwards in -direction of arrow 1- up to the stop.
- Press the piston slide valve in -direction of arrow 2- and disconnect the socket housing -B- upwards in -direction of arrow 3-.

The piston slide valve -A- remains in the top position.

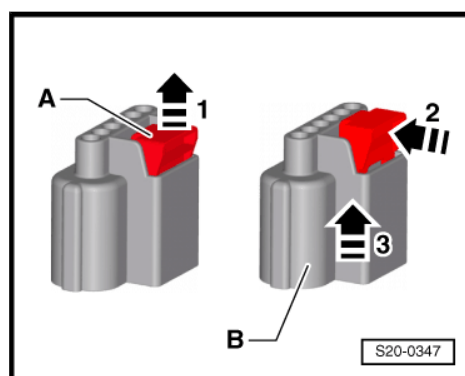

#### Fit on connector 8K0 973 706

- Push the socket housing -B- downwards up to the stop in -direction of arrow 1-.
- Slightly press the piston slide valve in -direction of arrow 2- and push it downwards in -direction of arrow 3-.
- The piston slide valve -A- can only be pushed downwards if the socket housing was pushed downwards »up to the stop«.
- For safety reasons, check the connector for secure catch by tightening it in the opposite direction.

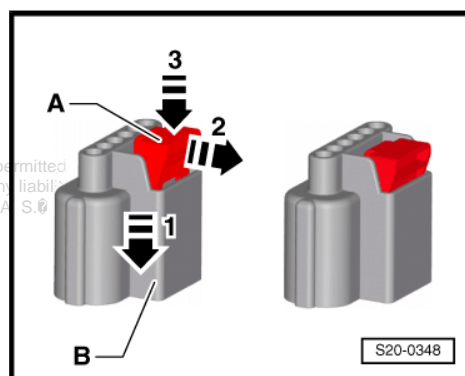

### 3 Activated charcoal container system

#### 3.1 Activated charcoal container system - Summary of components

**i** Note

- ◆ The hose connections are secured with spring strap clips or clamp-type clips.
- ◆ Always replace clamp-type clips with spring-type clips.
- ◆ Use pliers for spring strap clips to fit the spring strap clips.
- ◆ Safety precautions when working on the fuel supply system ⇒ [page 3](#).
- ◆ Rules of cleanliness when working on the fuel supply system ⇒ [page 5](#).

**1 - Activated charcoal filter**

- Fitting position: in right of engine compartment
- if the catch peg is unlocked, the activated charcoal filter can be removed from the holder
- Check fuel tank ventilation ⇒ [page 149](#)

**2 - Pressure holding valve with connection hose**

**3 - 8 Nm**

**4 - Vent line**

- check for firm seating
- from fuel tank

**5 - 8 Nm**

**6 - Support**

- for activated charcoal filter

**7 - Solenoid valve 1 for activated charcoal filter -N80-**

- Valve closed when ignition is switched off
- valve is actuated (pulsed) by engine control unit when engine is warm

**8 - Connecting hose**

- To intake manifold
- check for firm seating

**9 - Air admission fitting**

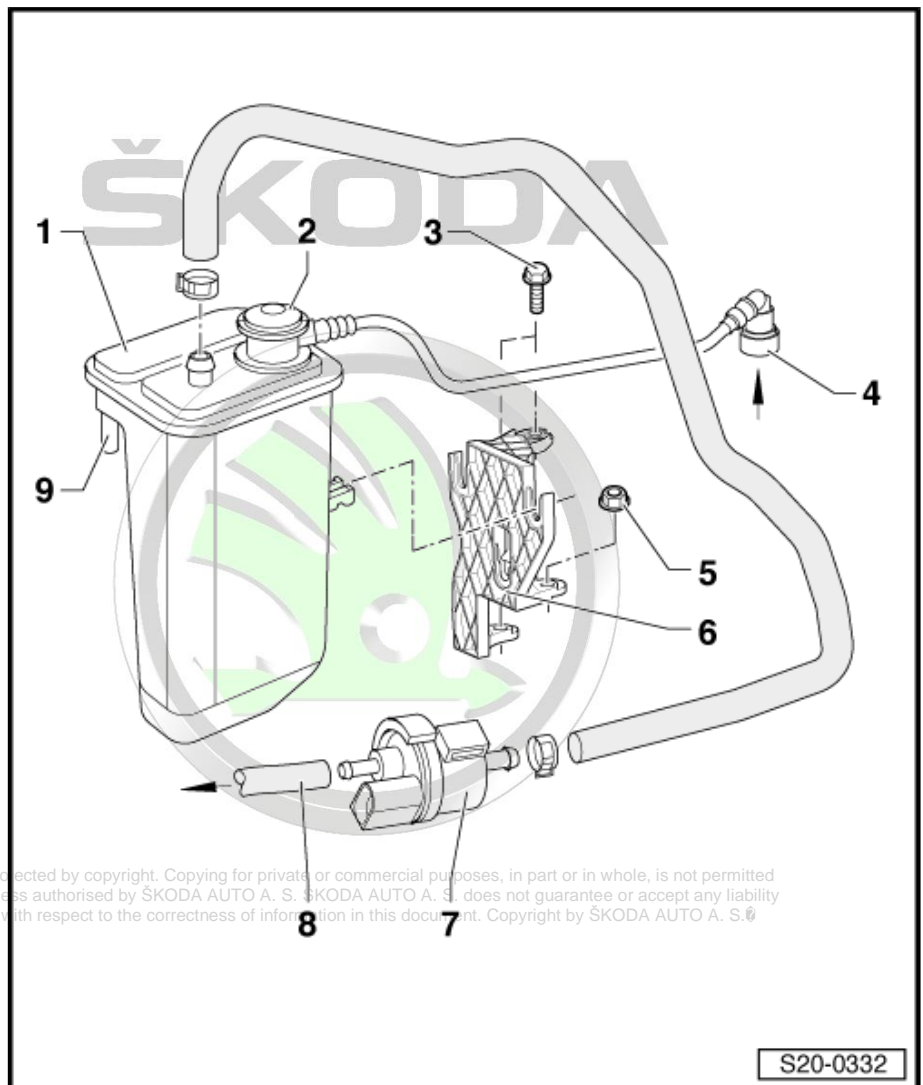

Protected by copyright. Copying for private or commercial purposes, in part or in whole, is not permitted unless authorised by ŠKODA AUTO A. S. ŠKODA AUTO A. S. does not guarantee or accept any liability with respect to the correctness of information in this document. Copyright by ŠKODA AUTO A. S. ©

#### 3.2 Check fuel tank ventilation

**Special tools and workshop equipment required**

- ◆ Hand vacuum pump , e.g. -VAS 6213-



ŠKODA

- ◆ Adapter set , e.g. - V.A.G 1318/17A-
- ◆ Adapter , e.g. -V.A.G 1318/20-1-

**i** Note

- ◆ The adapter set -V.A.G 1318/17A- replaces the adapter set -V.A.G 1318/17- .
- ◆ The figures shown in the description were not changed for this reason.

**Test condition**

- The ignition must be switched off.

**Test sequence**

- Detach vent line -1-. To do so press in the securing ring.

Protected by copyright. Copying for private or commercial purposes without the written permission of ŠKODA AUTO A. S. ŠKODA AUTO A. S. is prohibited. We accept no responsibility with respect to the correctness of information in this document.

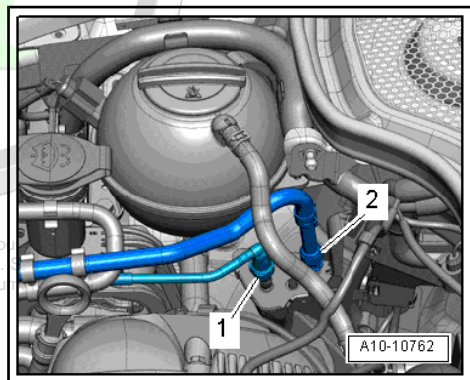

- Slide the control ring -1- on the hand vacuum pump -VAS 6213- in -the direction of arrow B- up to the stop.
- Operate the hand vacuum pump -VAS 6213 - several times.

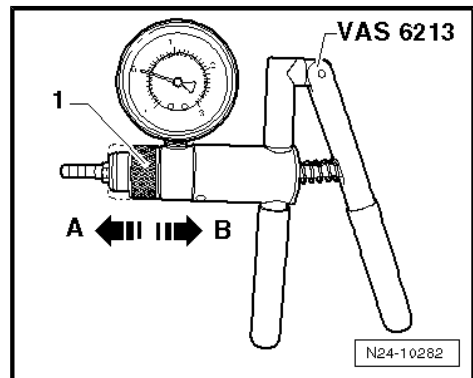

- Then connect the hand vacuum pump - VAS 6213- -1- on the vent line -2- as shown in the figure.
- Operate the hand vacuum pump -VAS 6213- several times.
- No vacuum should build up.

If a vacuum builds up.

- Check the air admission fitting on the activated charcoal filter for dirt and clean as required.

If no vacuum builds up:

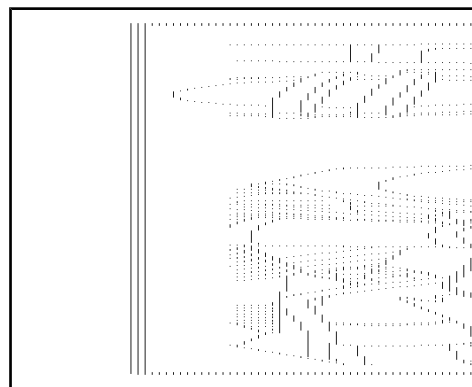



- Shut off air admission fitting -arrow- and once again operate the vacuum pump several times.
  - A vacuum should build up.
- If no vacuum builds up:
- Replace activated charcoal filter.

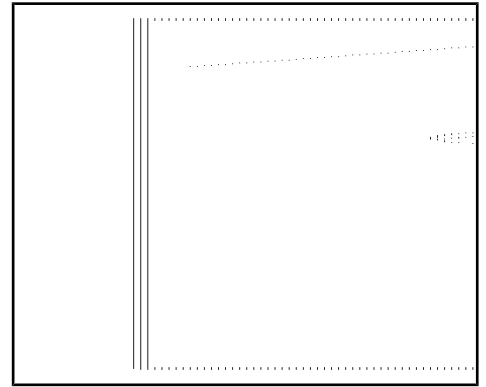

# ŠKODA



Protected by copyright. Copying for private or commercial purposes, in part or in whole, is not permitted unless authorised by ŠKODA AUTO A. S. ŠKODA AUTO A. S. does not guarantee or accept any liability with respect to the correctness of information in this document. Copyright by ŠKODA AUTO A. S. ©



## 21 – Turbocharging/supercharging

### 1 Exhaust gas turbocharger



Note

Observe the general notes for assembly work on the charge air system with exhaust gas turbocharger ⇒ [page 7](#).

#### 1.1 Exhaust turbocharger - Summary of components

Part I. ⇒ [page 153](#)

Part II. ⇒ [page 154](#)

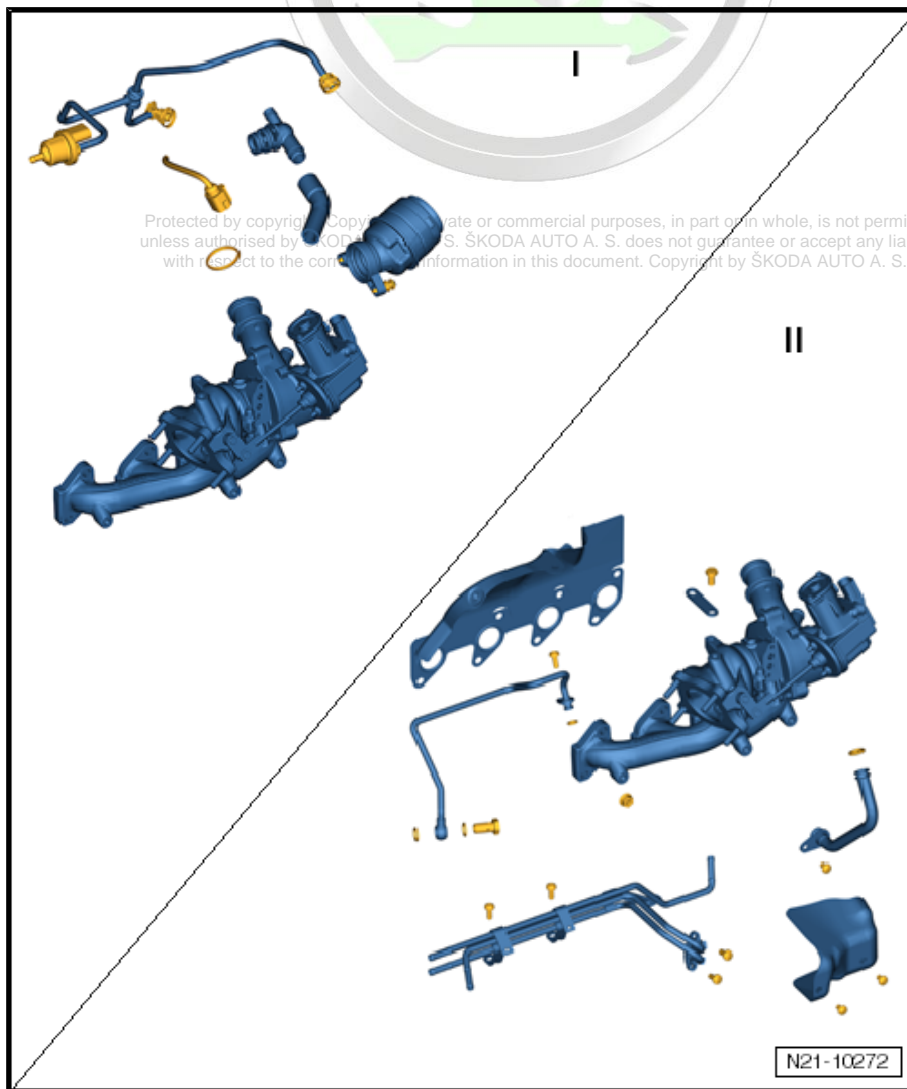



### 1.1.1 Part I

1 - Solenoid valve 1 for activated charcoal filter -N80-

- To intake manifold

2 - Non-return valve

- Fitting location: cylinder head cover

3 - Connecting hose

4 - 8 Nm

5 - Inlet connection

6 - Exhaust turbocharger with exhaust manifold

- with charge pressure regulator -V465-



**Note**

*The exhaust turbocharger can only be replaced complete with exhaust manifold and charge pressure regulator -V465-.*

- removing and installing  
 => [page 154](#)

7 - O-ring

- replace

8 - Connector

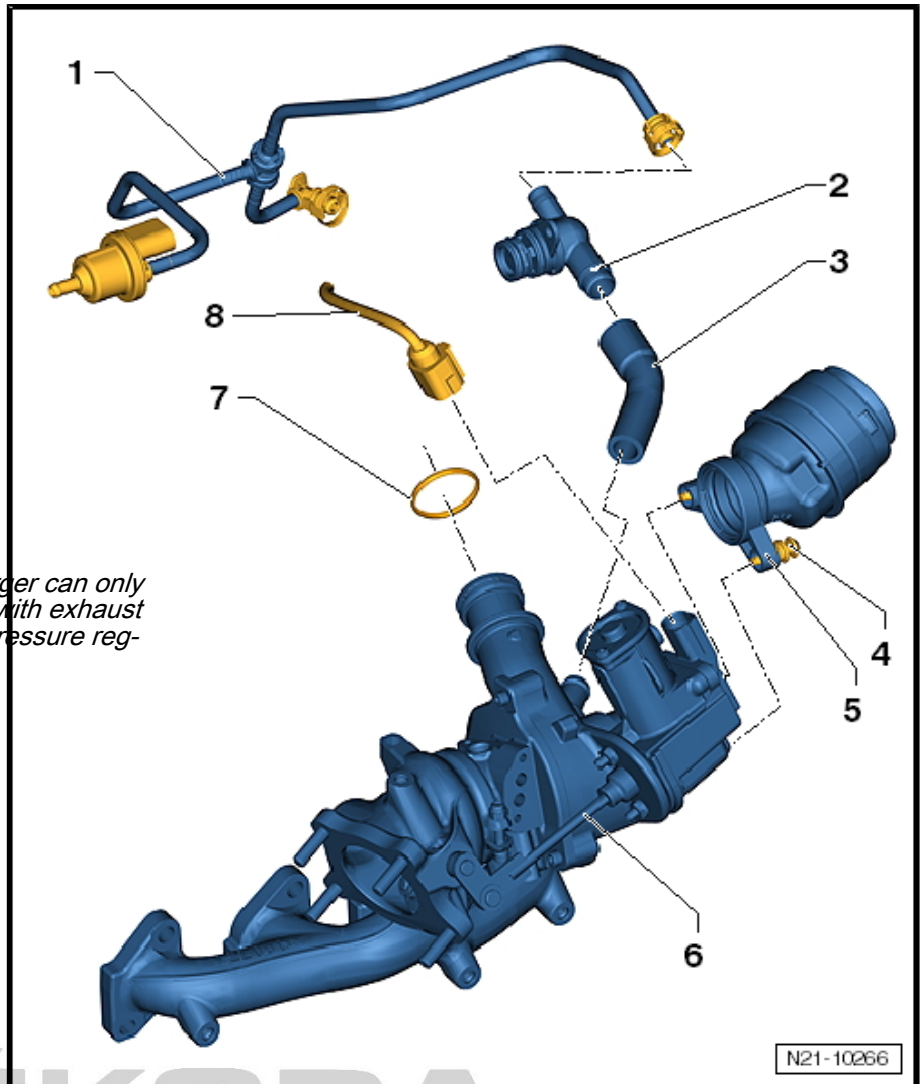

N21-10266





## 1.1.2 Part II

**1 - Gasket**

- replace

**2 - Support**

**3 - 20 Nm**

**4 - Exhaust turbocharger with exhaust manifold**

- with charge pressure regulator -V465-



**Note**

*The exhaust turbocharger can only be replaced complete with exhaust manifold and charge pressure regulator -V465-.*

- removing and installing  
=> [page 154](#)

**5 - O-ring**

- replace

**6 - Oil return pipe**

**7 - 8 Nm**

**8 - 10 Nm**

**9 - Heat shield**

**10 - 8 Nm**

**11 - Coolant pipes**

**12 - 8 Nm**

**13 - 18 Nm**

- observe the order of tightening up

=> [page 154](#)

- Tightening torque of pin screw in cylinder head: 18 Nm (insert oiled)

**14 - Sealing ring**

- replace

**15 - Hollow screw**

- Tightening torque: 20 Nm

**16 - Oil feed pipe**

**17 - O-ring**

- replace

**18 - 8 Nm**

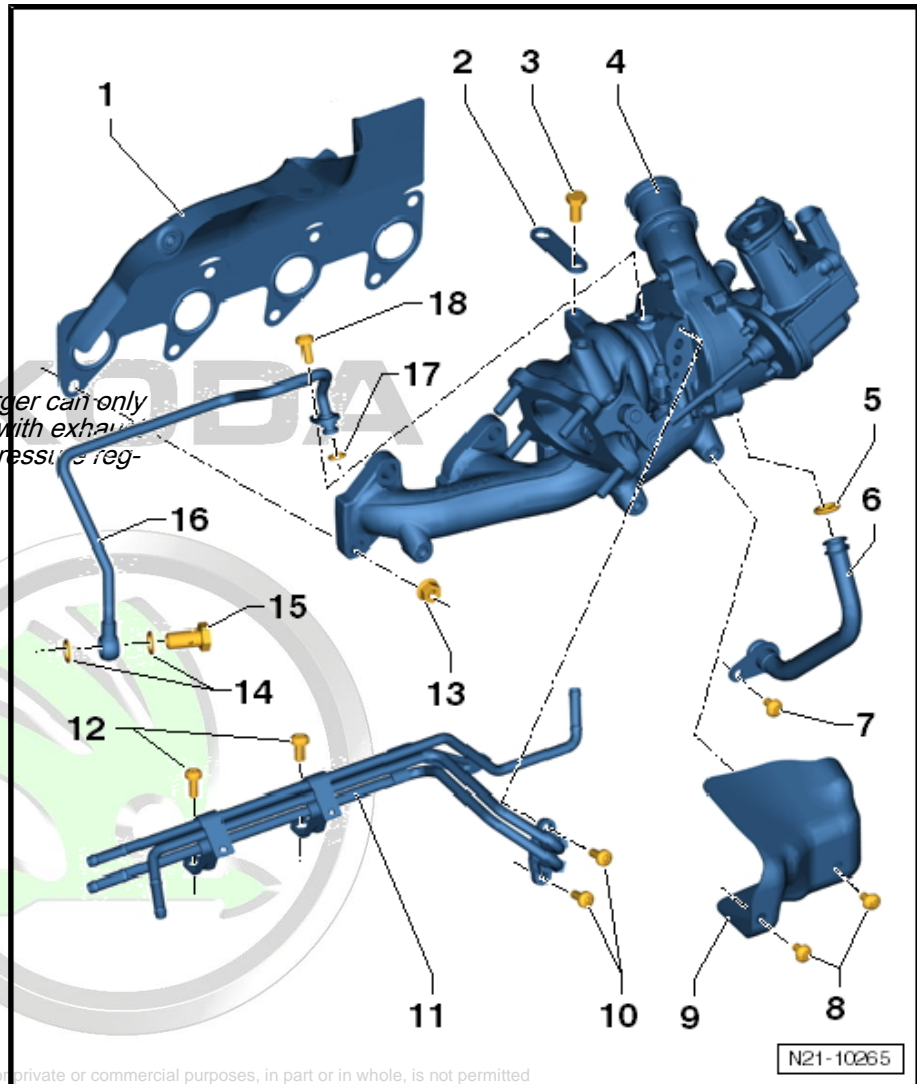

## 1.2 Removing and installing exhaust gas turbocharger

### Special tools and workshop equipment required

- ◆ Pliers for spring strap clamps
- ◆ Catch pan , e.g. -VAS 6208-

- ◆ Hot screw paste -G 052 112 A3-



### Caution

*In case a mechanical damage to the exhaust gas turbocharger is found, e.g. damage to the compressor wheel, it is not sufficient to only replace the turbocharger. In order to avoid consequential damage, perform the following tasks:*

- ◆ *Clean all oil lines.*
- ◆ *Change engine oil and oil filter.*
- ◆ *Inspect the air filter housing, the air filter element and the intake hoses for contaminations.*
- ◆ *Inspect the whole charge-air routing and the charge air cooler for foreign bodies.*

*If foreign bodies are detected in the charge air system, the complete charge-air routing must be cleaned and if necessary the charge air cooler must also be replaced.*



### Note

- ◆ *Observe rules for cleanliness ⇒ [page 3](#).*
- ◆ *Observe general instructions for charge-air system ⇒ [page 7](#).*

### Removing

- Disconnect battery ⇒ Electrical System ⇒ Rep. gr. 27 .
- Remove V-ribbed belt ⇒ [page 26](#) .
- Drain coolant ⇒ [page 99](#) .
- Detach hoses -1- and plugs -2- from exhaust gas turbocharger.
- Release screws -1- and remove retaining clip.

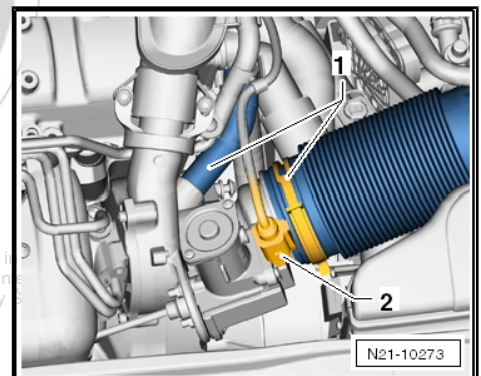

- Disconnect plug -2- at charge pressure sender -G31- with intake air temperature sender 2 -G299 - .
- Release the catches in -direction of arrow- and detach the pressure pipe -3- first of all from the throttle valve control unit -J338 - and then from the exhaust gas turbocharger.
- Fold open the cover -4- and release the fixing screw.

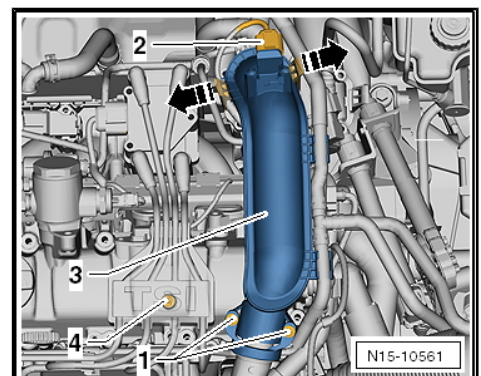



- Disconnect all the spark plug connectors -arrows- using the extractor -T10112 A- from the spark plugs and lay the ignition cables to the rear.
- Detach coolant hoses from coolant pipes -1-.



**Note**

*Make sure that the oil does not penetrate into the generator!  
Therefore, cover the generator with a clean cloth!*

- Unscrew the hollow screw -4- of the oil pipe.
- Release fixing screws -2- and -3- and remove oil and coolant pipes.
- Remove lambda probe -G39- -5-.
- Release the top fixing screw of the AC generator and press the generator slightly downwards.
- Release fixing screws -arrows- and remove the heat shield from the exhaust turbocharger.

- Remove holder -1-.
- Unscrew fixing nuts -arrows- at exhaust gas turbocharger.
- Remove noise insulation ⇒ Body Work ⇒ Rep. gr. 50 .
- Separate plug connections -1-.

- Unscrew fixing nuts -2-.
- Release the fixing screws of the bracket -3- and remove the catalytic converter downwards.

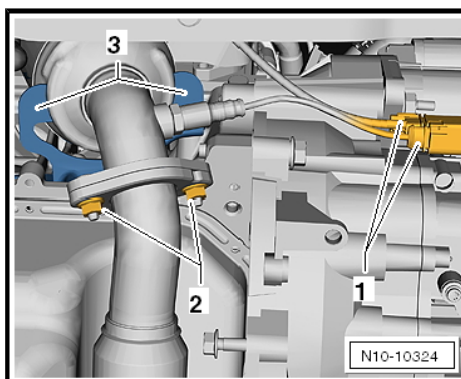
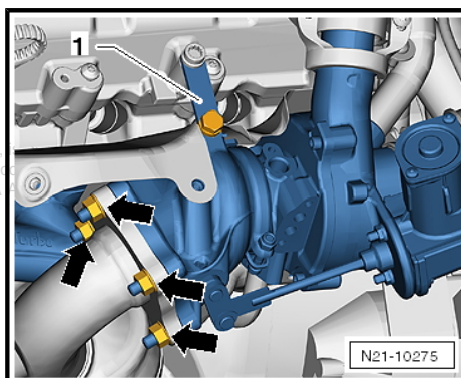
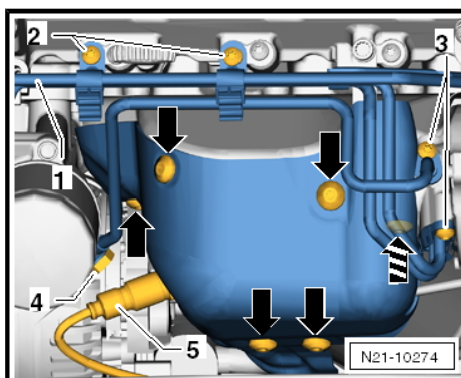
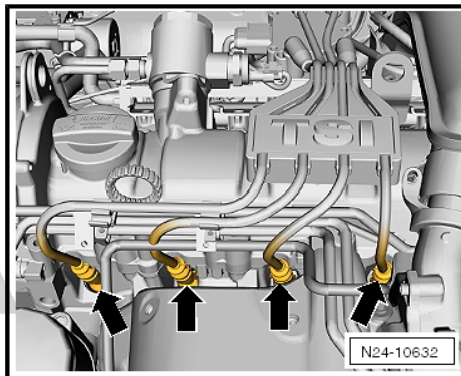



- Release the fixing screw -1- of the oil return pipe -2- and pull the oil return pipe out of the exhaust gas turbocharger.
- Release the fixing screws of the heat shield -3- and remove the panel from the exhaust manifold.

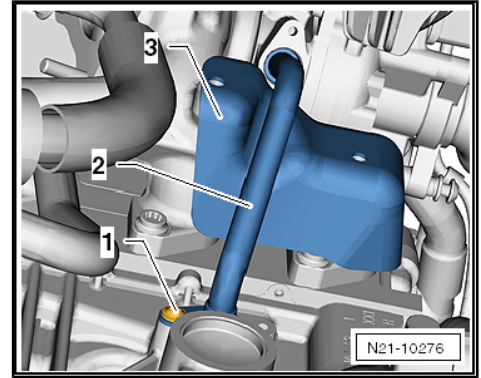

- Unscrew all the fixing nuts -arrows- of the exhaust manifold.
- Remove exhaust manifold with exhaust turbocharger from cylinder head.
- Remove the gasket from the stud bolts.

#### Install

- Position exhaust turbocharger with exhaust manifold and gasket at cylinder head.

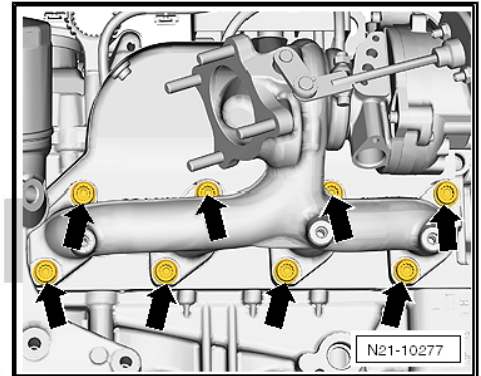

Protected by copyright. Copying for private or commercial purposes, in part or in whole, is not permitted unless authorised by ŠKODA AUTO A. S. ŠKODA AUTO A. S. does not guarantee or accept any liability with respect to the correctness of information in this document. Copyright by ŠKODA AUTO A. S. ©



- Tighten the fixing nuts to 18 Nm in the specified order -A- to -H-.

Further installation occurs in reverse order, while paying attention to the following:



**Note**

- ◆ After installing the turbocharger, run engine at idling speed for about 1 minute to ensure that oil is supplied to the turbocharger.
- ◆ Replace the gaskets, the sealing rings and the self-locking nuts.
- ◆ Fill the exhaust turbocharger with engine oil at the connection fitting for the oil feed line.
- ◆ Hose connections and hoses of the charge air system must be free of oil and grease before being installed.
- ◆ Secure all hose connections with corresponding hose clips.

Tightening torques:

Exhaust gas turbocharger - Summary of components part I.

⇒ [page 153](#)

Exhaust turbocharger - Summary of components part II

⇒ [page 154](#)

Catalytic converter and component parts - Summary of components ⇒ [page 188](#)

- Attach AC generator ⇒ Electrical System; Rep. gr. 27 ; removing and installing AC generator .
- Install the V-ribbed belt ⇒ [page 26](#) .
- Top up coolant ⇒ [page 99](#) .
- Connect battery ⇒ Electrical System ⇒ Rep. gr. 27 .

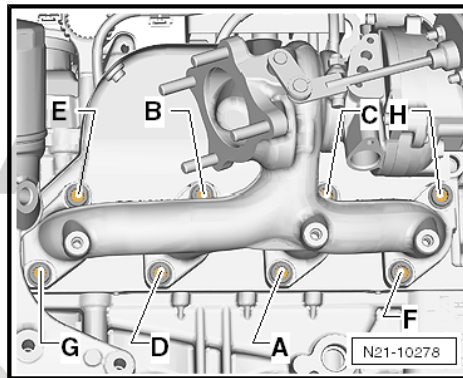

Part of this document may be reproduced for non-commercial purposes, in part or in whole, is not permitted unless authorised by ŠKODA AUTO A. S. ŠKODA AUTO A. S. does not guarantee or accept any liability with respect to the correctness of information in this document. Copyright by ŠKODA AUTO A. S.

## 2 Charge air system with exhaust gas turbocharger

Observe the general notes for assembly work on the charge air system with exhaust gas turbocharger ⇒ [page 7](#) .

### 2.1 Charge air system - Summary of components

#### Note

- ◆ *This engine is fitted with a radiator combination of engine and low temperature radiators for charge air system.*
- ◆ *Engine and low temperature radiators are arranged as one component part.*

#### 1 - Radiator with low temperature radiator for charge air system

- removing and installing ⇒ [page 108](#)

#### 2 - Intake manifold

- removing and installing ⇒ [page 169](#)

#### 3 - Seal

- pay attention to correct seating when installing the charge air cooler

#### 4 - Gasket

- replace if damaged

#### 5 - Charge air cooler

- removing and installing ⇒ [page 160](#)

#### 6 - Coolant hose

- to exhaust gas turbocharger

#### 7 - 7 Nm

- when installing first tighten evenly by hand, then tighten crosswise from the inside to the outside to the recommended tightening torque

#### 8 - Coolant hose

- to the expansion reservoir

#### 9 - Hose clamp

- attached to the timing case

#### 10 - Coolant hose

- to exhaust gas turbocharger

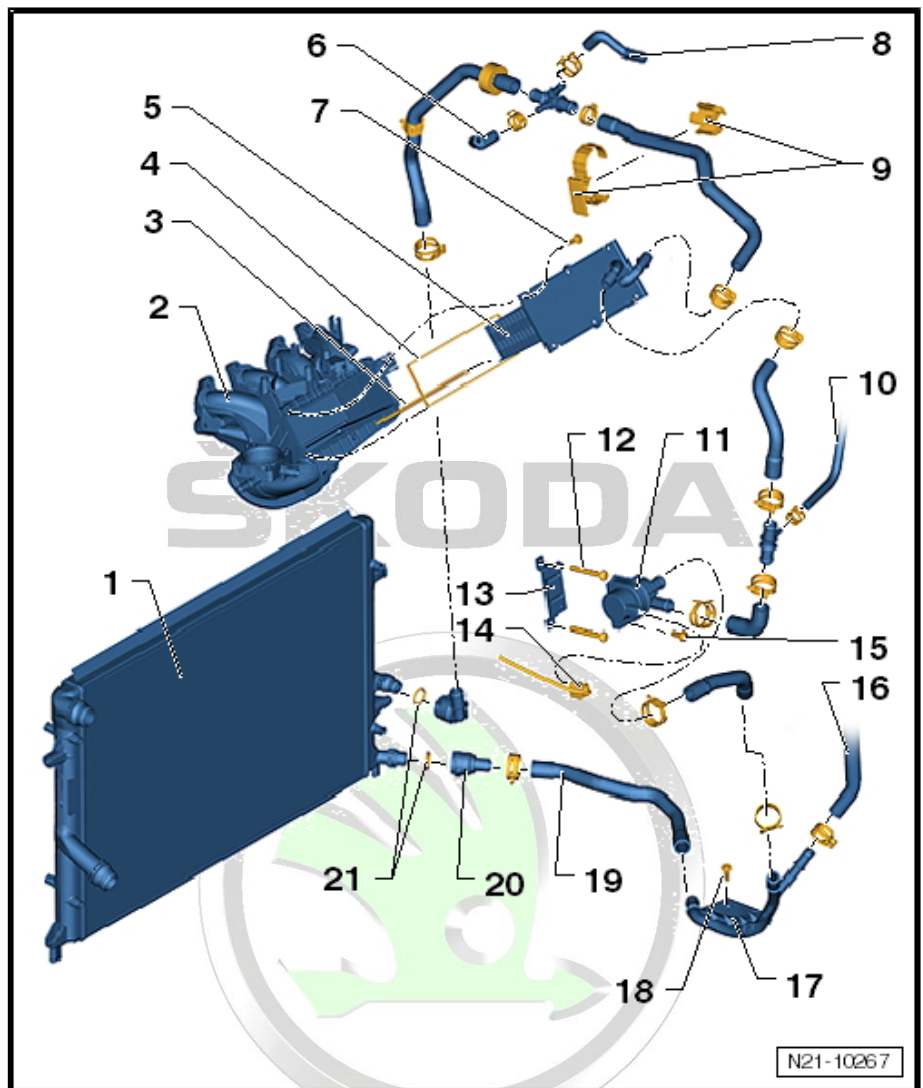

Protected by copyright. Copying for private or commercial purposes, in part or in whole, is not permitted unless authorised by ŠKODA AUTO A. S. ŠKODA AUTO A. S. does not guarantee or accept any liability with respect to the correctness of information in this document. Copyright by ŠKODA AUTO A. S. ©

**11 - Coolant recirculation pump -V50-**

- removing and installing ⇒ [page 105](#)

**12 - 8 Nm****13 - Support****14 - Connector****15 - 10 Nm****16 - Coolant hose**

- to engine oil cooler

**17 - Coolant pipe**

- attached to the oil pan

**18 - 8 Nm****19 - Bottom coolant hose****20 - Connection fittings****21 - O-ring**

- replace if damaged

# ŠKODA

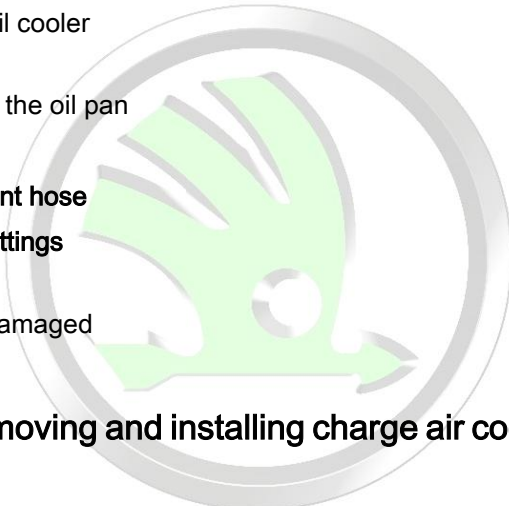

## 2.2 Removing and installing charge air cooler

**Special tools and workshop equipment required**

- ◆ Hose clamps up to  $\varnothing$  25 mm -MP7-602 (3094)-
- ◆ Pliers for spring strap clamps
- ◆ Catch pan , e.g. -VAS 6208-

**Note**

Observe the general notes for assembly work on the charge air system ⇒ [page 7](#) .

## Removing

- Disconnect plug -1- and hose -3- from activated charcoal filter system solenoid valve 1 -N80- .
- Remove the lines with the non-return valve -5- and the activated charcoal filter system solenoid valve 1 -N80- from the intake manifold.
- Disconnect coolant hoses -3- with hose clamps -3094 - and detach from charge-air cooler.
- Release the fixing screws of the ignition transformer -N152- and carefully place the ignition transformer onto the cylinder head cover.
- Release fixing screws at charge air cooler -4-.
- Carefully pull the charge air cooler -4- out of the intake manifold.

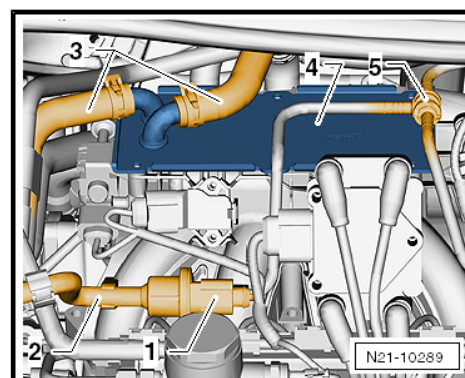

## Note

*Pour the residual coolant out of the charge air cooler into a collecting tank.*

Protection against copying for private or commercial purposes, in part or in whole, is not permitted unless expressly permitted by ŠKODA AUTO A. S. ŠKODA AUTO A. S. does not guarantee or accept any liability with respect to the correctness of information in this document. Copyright by ŠKODA AUTO A. S. ©

## Install

Installation is performed in the reverse order, pay attention to the following points:

- Slide the seal -1- in -direction of arrow- onto the edge of the charge air cooler -2-.
- Check the correct seating of the new gasket at the intake manifold.
- Slide the charge air cooler into the intake manifold.
- Press down the charge-air cooler up to the stop into the intake manifold.

## Note

*Do not tilt the charge-air cooler when installing.*

- First tighten the fixing screws uniformly crosswise until the screw heads are positioned.
- Tighten the fixing screws crosswise to the tightening torque: 7 Nm.

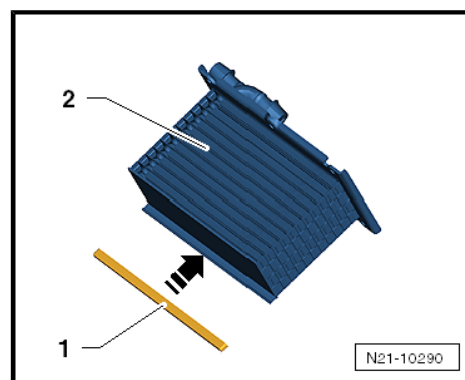



## 24 – Mixture preparation - injection

### 1 Fitting location of the injection system

**1 - Oil pressure switch -F1-**

- in the left cylinder head
- check ⇒ [page 96](#)

**2 - Solenoid valve for coolant circuit -N492-**

**3 - Solenoid valve 1 for activated charcoal filter -N80-**

**4 - Intake manifold pressure sender -G71- and intake air temperature sender -G42-**

**5 - Engine control unit -J623-**

- removing and installing ⇒ [page 186](#)

**6 - Control valve for fuel pressure -N276-**

**7 - Knock sensor 1 -G61-**

- at rear cylinder block
- 20 Nm

**8 - Hall sender -G40-**

**9 - Ignition transformer -N152-**

- ◆ D ignition transformer = ignition cable cyl. 1
- ◆ B ignition transformer = ignition cable cyl. 2
- ◆ C ignition transformer = ignition cable cyl. 3
- ◆ A ignition transformer = ignition cable cyl. 4

**10 - Injection valves**

- Injection valve for cylinder 1 -N30-
- Injection valve for cylinder 2 -N31-
- Injection valve for cylinder 3 -N32-
- Injection valve for cylinder 4 -N33-
- with Teflon gasket ring and supporting washer
- after removing the injection valve, the Teflon gasket ring and the supporting washer must be replaced ⇒ [page 179](#)
- Remove and install injection valve ⇒ [page 177](#)

**11 - Charge pressure sender -G31- with intake air temperature sender 2 -G299-**

**12 - Throttle valve control unit -J338-**

- removing and installing ⇒ [page 167](#)
- clean ⇒ [page 169](#)
- in case of replacement, erase initialisation values and adapt the engine control unit -J623- ⇒ Vehicle diagnostic, testing and information system VAS 5051.

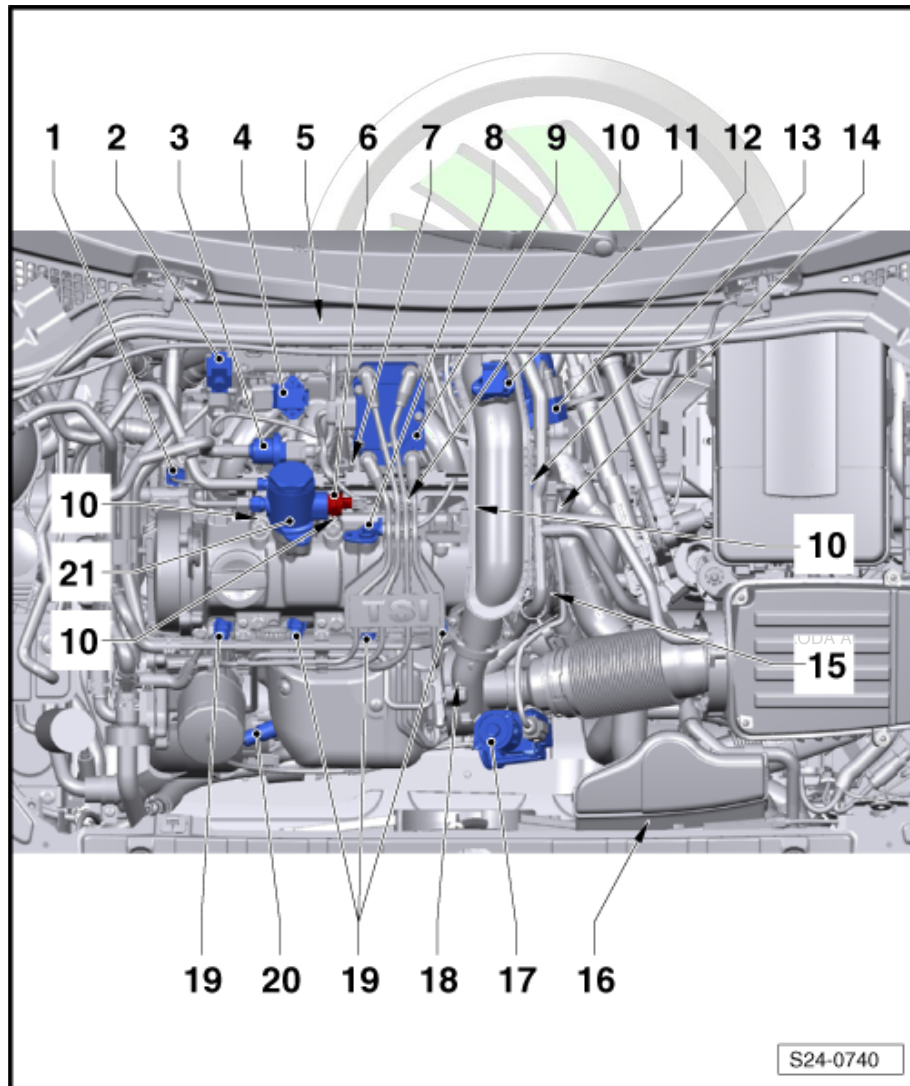

13 - Fuel pressure sender -G247-

- check ⇒ [page 183](#)

14 - Engine speed sender -G28-

- removing and installing ⇒ [page 196](#)

15 - Coolant temperature sender -G62-

16 - Coolant temperature sender at radiator outlet -G83-

17 - Charge pressure regulator -V465 -



Note

*The charge pressure regulator - V465- can only be replaced complete with exhaust gas turbocharger and exhaust manifold.*

18 - Lambda probe downstream of catalytic converter -G130- and heater of lambda probe 1 downstream of catalytic converter -Z29-

19 - Spark plugs, 25 Nm

20 - lambda probe -G39- and heating for lambda probe -Z19-

21 - High pressure pump with fuel pressure regulating valve -N276-

- removing and installing ⇒ [page 174](#)

ŠKODA





## 2 Intake manifold and fuel distributor

### 2.1 Intake manifold - Summary of components

Part I. ⇒ [page 165](#)

Part II. ⇒ [page 166](#)

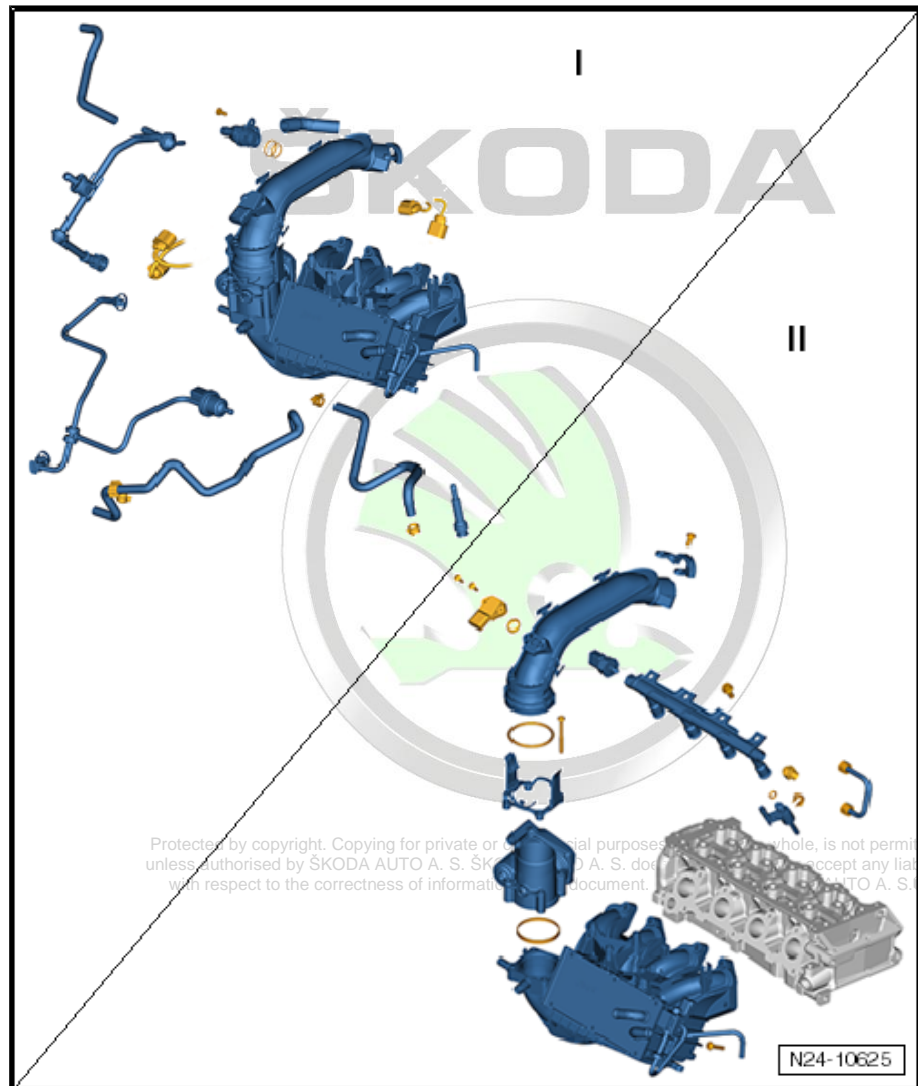



## 2.1.1 Part I

- 1 - Connecting hose**
  - at camshaft housing
- 2 - Connector**
  - for intake manifold pressure sender -G71-
- 3 - Connector**
  - for solenoid valve for coolant pump control
- 4 - 10 Nm**
- 5 - Non-return valve**
  - for crankcase ventilation
- 6 - Connecting hose**
  - to exhaust gas turbo-charger
- 7 - O-ring**
  - replace
- 8 - Intake manifold**
  - removing and installing  
⇒ [page 169](#)
  - with intake manifold pressure sender -G71-
- ◆ The intake manifold pressure sender -G71- is attached to the intake manifold only using a plastic clip.
- ◆ If the plastic clip is damaged, attach the sender to the intake manifold with screws ⇒ Electronic Catalogue of Original Parts . Tightening torque: 3 Nm.
- 9 - Connecting hose**
  - to the coolant pump
- 10 - Solenoid valve for coolant circuit -N492-**
- 11 - Connection fittings**
- 12 - Clamp**
- 13 - Fuel hose**
  - to high pressure pump
- 14 - Solenoid valve 1 for activated charcoal filter -N80-**
- 15 - Connecting hose**
  - to the activated charcoal filter system
- 16 - Connecting hose**
- 17 - Connector**
  - for throttle valve control unit -J338-

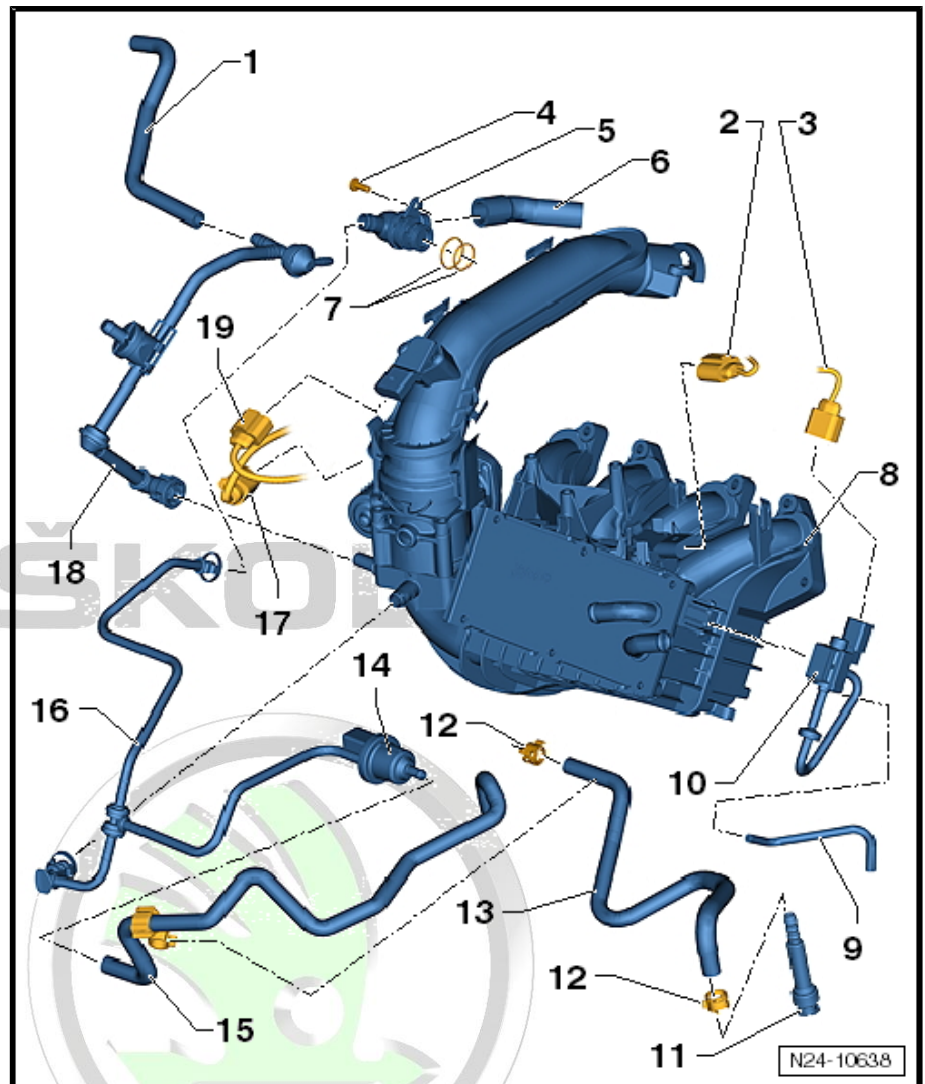

Protected by copyright. Copying for private or commercial purposes, in part or in whole, is not permitted unless authorised by ŠKODA AUTO A. S. ŠKODA AUTO A. S. does not guarantee or accept any liability with respect to the correctness of information in this document. Copyright by ŠKODA AUTO A. S. ©



18 - Connecting hose

19 - Connector

- for charge pressure sender -G31- with intake air temperature sender 2 -G299-



2.1.2 Part II

1 - Pressure pipe

2 - 7 Nm

3 - Retaining clip

4 - Fuel pressure sender - G247- , 22 Nm

- Check fuel pressure sender -G247-  
=> [page 183](#)

5 - Fuel distributor

6 - 20 Nm

7 - 30 Nm

8 - 25 Nm

9 - 25 Nm

10 - O-ring

- replace

11 - Spring element

- replace bottom part of intake manifold/fuel distributor after each removal
- check for correct seating on injector

12 - Injection valve for cylinder 1 -N30-

- Injection valve for cylinder 2 -N31-
- Injection valve for cylinder 3 -N32-
- Injection valve for cylinder 4 -N33-

- with Teflon gasket ring and supporting washer

- after removing the injection valve, the Teflon gasket ring and the supporting washer must be replaced => [page 179](#)

- Remove and install injection valve => [page 177](#)

13 - Cylinder head

- removing and installing => [page 81](#)

14 - 20 Nm

15 - Intake manifold

- removing and installing => [page 169](#)
- with intake manifold pressure sender -G71-

◆ The intake manifold pressure sender -G71- is attached to the intake manifold only using a plastic clip.

◆ If the plastic clip is damaged, attach the sender to the intake manifold with screws => Electronic Catalogue of Original Parts . Tightening torque: 3 Nm.

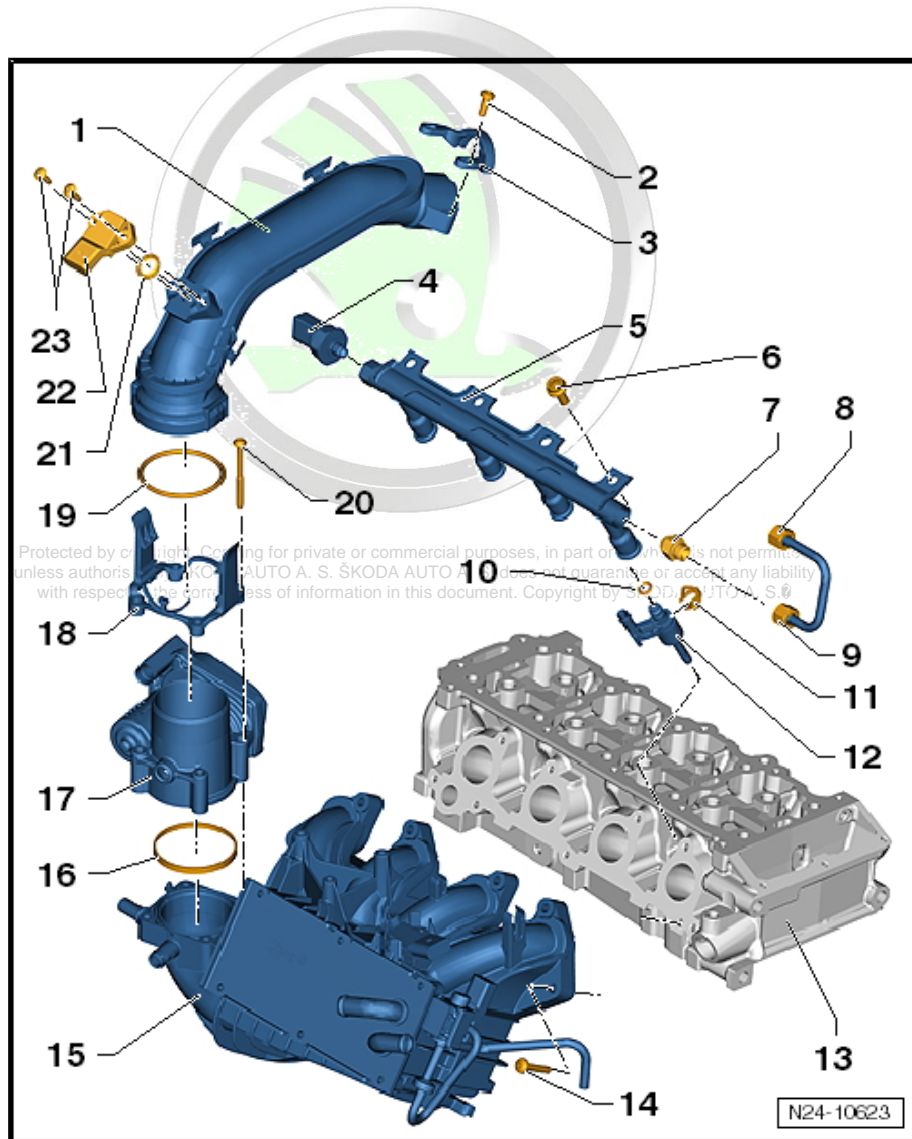

## 16 - Gasket

- replace

## 17 - Throttle valve control unit -J338-

- removing and installing ⇒ [page 167](#)
- clean ⇒ [page 169](#)
- in case of replacement, erase initialisation values and adapt the engine control unit -J623- ⇒ Vehicle diagnostic, testing and information system VAS 5051.

## 18 - Adapter

## 19 - O-ring

- replace

## 20 - 7 Nm

## 21 - O-ring

- replace

## 22 - Charge pressure sender -G31- with intake air temperature sender 2 -G299-

## 23 - 5 Nm

## 2.2 Removing and installing the throttle valve control unit -J338-



### Note

- ◆ *Safety precautions when working on the fuel supply system* ⇒ [page 3](#).
- ◆ *Rules of cleanliness when working on the fuel supply system* ⇒ [page 5](#).

### Removing

- Release screws -1- and remove retaining clip.
- Disconnect plug -2- at charge pressure sender -G31- with intake air temperature sender 2 -G299 - .
- Release the catches in -direction of arrow- and detach the pressure pipe -3- first of all from the throttle valve control unit -J338 - and then from the exhaust gas turbocharger.

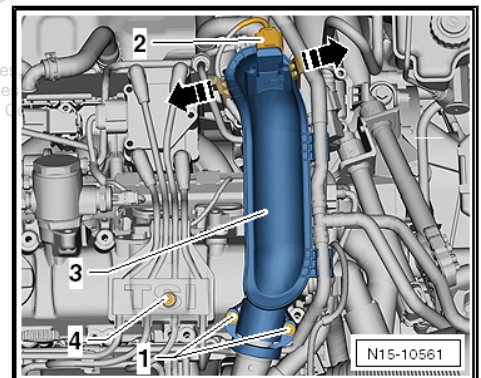



- Disconnect the plug -1- from the throttle valve control unit - J338 - .
- Release the fixing screws -2- and remove the throttle valve control unit -J338- from the intake manifold.

**Install**

- Insert a new gasket ring in the groove of the intake manifold.

- Position the throttle valve control unit -3- together with the adapter -2- and the fixing screws -1- onto the intake manifold -4-.



- Tighten fixing screws -2- to 7 Nm.
- Fit the plug -1- at the throttle valve control unit -3-.



Protected by copyright. Copying for private or commercial purposes, in part or in whole, is not permitted without the express authorisation by ŠKODA AUTO A. S. ŠKODA AUTO A. S. does not guarantee or accept any liability for the correctness of information in this document. Copyright by ŠKODA AUTO A. S.

**Note**

*Before fitting the O-rings at the exhaust turbocharger and in the pressure pipe moisten slightly with engine oil.*

- Fit the pressure pipe -3- at the turbocharger.
- Press the pressure pipe -3- onto the throttle valve control unit.
- During this procedure the retaining clips must click audibly into place.
- Tighten screws -1- of retaining clip to 7 Nm.
- Connect plug -2- at charge pressure sender -G31- with intake air temperature sender 2 -G299 - .

If a new throttle valve control unit was installed:

- Erase initialisation values and adapt the engine control unit - J623- to the throttle valve control unit ⇒ Vehicle diagnostic, testing and information system VAS 5051.

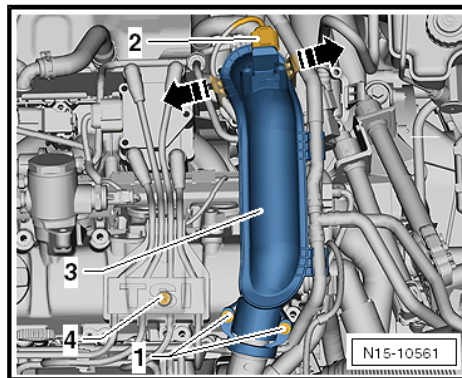
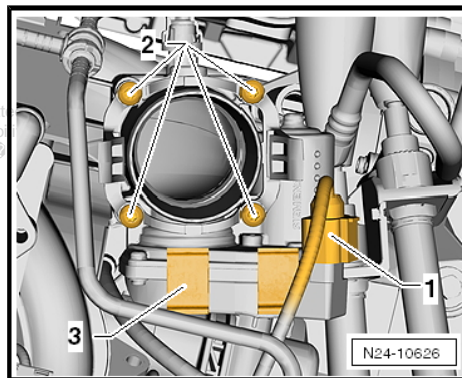
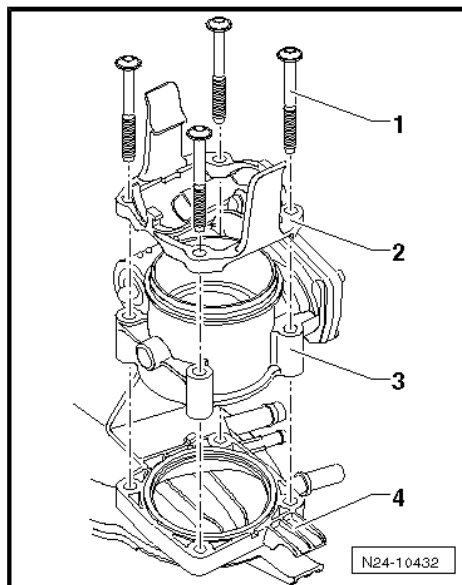
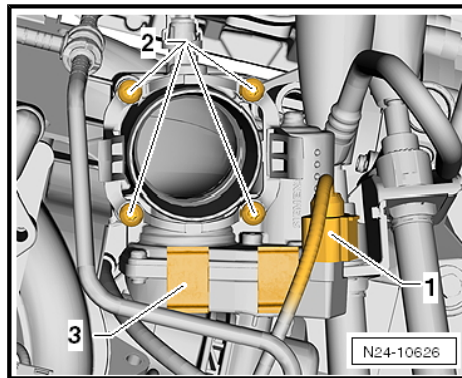

## 2.3 Clean throttle valve control unit -J338-

### Note

- ◆ *Safety precautions when working on the fuel supply system ⇒ [page 3](#) .*
- ◆ *Rules of cleanliness when working on the fuel supply system ⇒ [page 5](#) .*
- ◆ *If a new engine control unit -J623- is fitted, the throttle valve control unit must be adapted. The adaptation must only be carried out with a new or cleaned throttle valve control unit, because dirt/carbon deposits in the end stop of the throttle valve can lead to incorrect adaptation values.*
- ◆ *The throttle valve support must not be scratched when cleaning.*
- Remove the throttle valve control unit ⇒ [page 167](#) .
- Open the throttle valve manually and block the throttle valve in the opened position with a suitable object (e.g. plastic or wooden wedge)-arrow-



### WARNING

**Acetone is easily inflammable. Observe the accident prevention regulations and the safety instructions when handling easily inflammable fluids. Do not use compressed air when cleaning the throttle valve. Wear safety goggles and safety clothing, in order to avoid injuries and skin contact with fuel.**

- Thoroughly clean the throttle valve support, in particular the area of the closed throttle valve -arrows-, with commercially available acetone and a paint brush.
- Wipe the throttle valve support with a fluffy cloth.
- Let the acetone dry off completely and re-install the cleaned throttle valve control unit.

Protected by copyright. Copying for private or commercial purposes, in part or in whole, is not permitted unless authorised by ŠKODA AUTO A. S. ŠKODA AUTO A. S. does not guarantee or accept any liability with respect to the correctness of information in this document. Copyright by ŠKODA AUTO A. S. ©

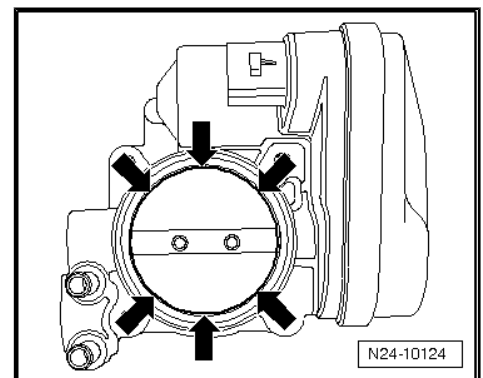
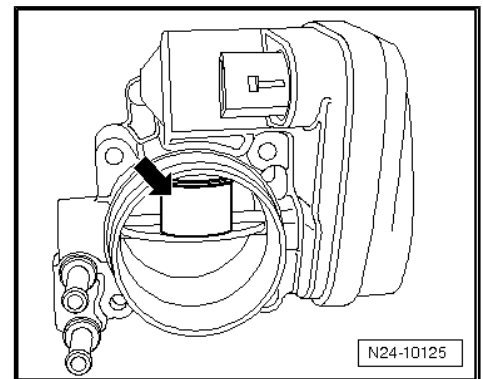

## 2.4 Removing and installing intake manifold

### Special tools and workshop equipment required

- ◆ Pliers for spring strap clamps
- ◆ Hose clamps up to Ø 25 mm -MP7-602 (3094)-



## Removing



### Note

# ŠKODA

- ◆ *Safety precautions when working on the fuel supply system*  
⇒ [page 3](#) .
- ◆ *Rules of cleanliness when working on the fuel supply system*  
⇒ [page 5](#) .
- Switch off the ignition and all electrical components and take out the ignition key.
- Remove the throttle valve control unit ⇒ [page 167](#) .
- Disconnect the fuel intake hose -9- and the plug from the activated charcoal filter system solenoid valve 1 -N80- and remove the valve from the intake manifold.
- Disconnect plugs -1- and -4-.
- Release the fixing screws -7- and carefully place the ignition transformer -N152- -6- onto the cylinder head cover.
- Detach connecting hose -5- from intake manifold.
- Disconnect the vacuum line of the solenoid valve for coolant circuit -N492- -2- from the coolant pump.
- Pinch off coolant hoses for charge-air cooler with hose clamps -MP7-601- .
- Slacken the clamps -3- and detach the coolant hoses from the charge-air cooler.
- Slacken the fixing screws -arrows- crosswise and carefully remove the intake manifold upwards.

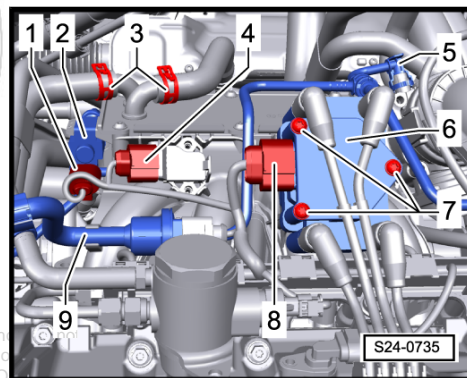

### Note

*Pour the residual coolant out of the charge air cooler into a collecting tank.*

## Install

Installation occurs in reverse order to removal.

- ◆ Tightening torque of fixing screws for intake manifold: 20 Nm
- ◆ Tightening torque and tightening sequence for charge-air cooler: ⇒ [page 159](#)
- Check, top up and bleed cooling system ⇒ [page 99](#) .

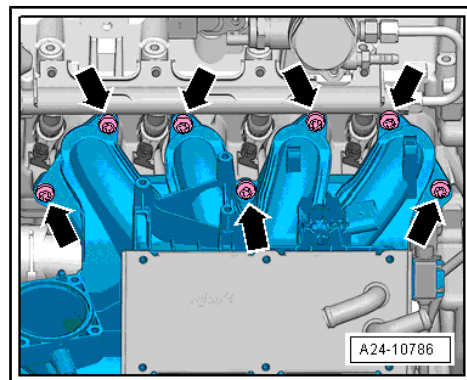



## 3 Air filter

### 3.1 Air filter - Summary of components

Removing and installing air filter ⇒ [page 171](#) .

1 - Upper part of air filter housing

2 - 2 Nm

3 - 2 Nm

4 - Support

5 - Filter element

6 - Rubber-metal bearing, 8 Nm

- with captive screw

7 - Seals

- replace if damaged

8 - Bottom part of the air filter housing

- removing and installing ⇒ [page 171](#)

9 - Rubber bearing

10 - Inlet connection

- with cover

11 - 2 Nm

12 - Intake air duct

13 - 2 Nm

14 - Spring strap clamp

- use hose binding claw, e.g. -VAS 6340- for removing and installing

15 - Air intake hose

16 - Vacuum hose

- replace if damaged
- to cylinder head cover

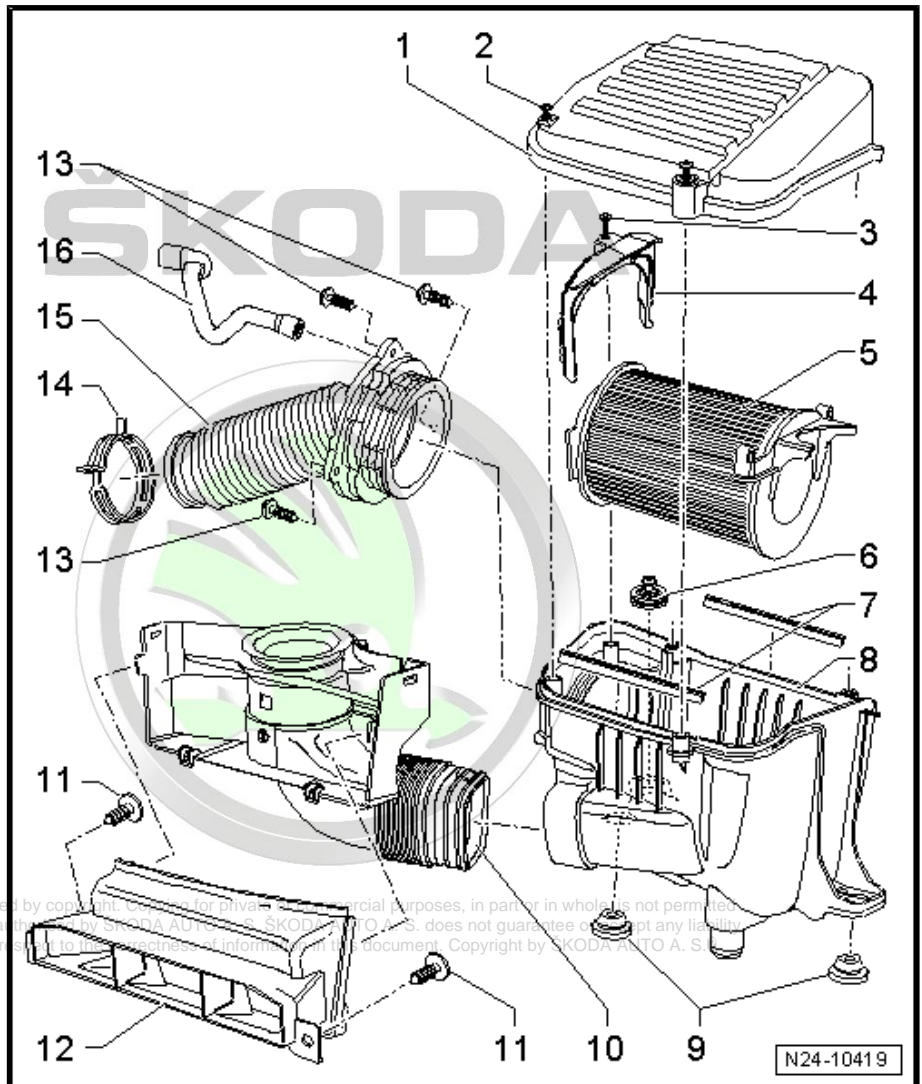

N24-10419

### 3.2 Removing and installing air filter

Special tools and workshop equipment required

- ◆ Pliers for spring strap clamps



## Removing

- Press the catches -arrows- and take the cover -1- from the inlet connection.
- Pull the inlet connection out of the intake air duct.
- Remove the spring strap clamp -2- with the intake hose from the exhaust gas turbocharger.

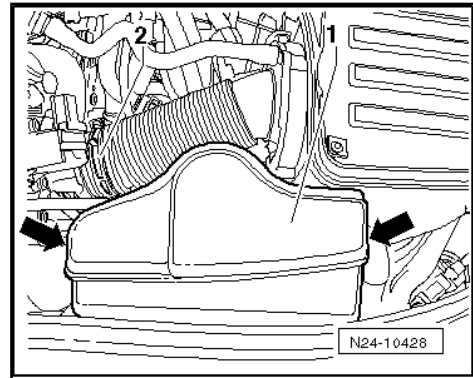

- Detach vacuum hose -1- from air filter housing.
- Unscrew the fixing screw -2- and pull the air filter housing towards the top from the bearing bolts -3-.

## Install

Installation is carried out in the reverse order. Pay attention to the following:

- Press the air filter housing from the top onto the bearing bolts -3-.
- Tighten fixing screw -2- to 8 Nm.
- Fit the vacuum hose -1- at the connection fitting of the air filter housing.

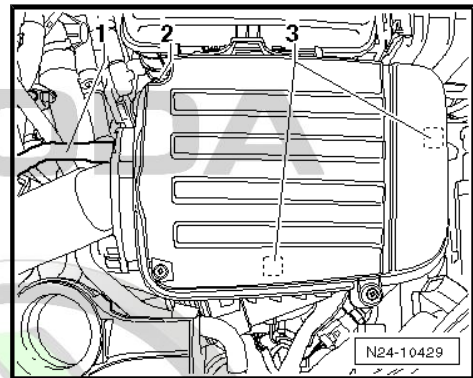
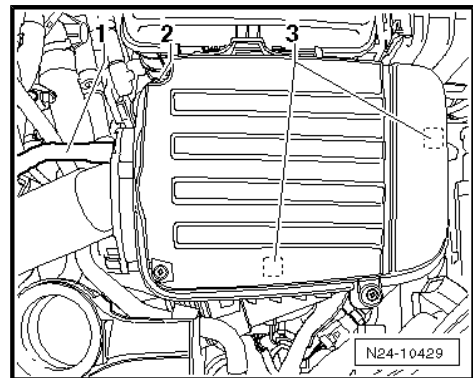

## 4 High pressure pump

### 4.1 High pressure pump - Summary of components



#### WARNING

*The injection system consists of a high pressure part (max. pressure of 12 MPa = 120 bar) and a low pressure part (pressure of approx. 0.6 MPa = 6 bar).*

*Before opening the high pressure area, e.g. removing the high pressure pump, the fuel distributor, the injection valves, the fuel pipes or the fuel pressure sender -G247-, the fuel pressure in the high pressure area with a remaining pressure of approx. 0.6 MPa (6 bar) must be reduced. The procedure for this is described in the chapter „release pressure in the high pressure area of the fuel system“ => [page 4](#).*

- 1 - 15 Nm
- 2 - Fuel hose
  - Low pressure
  - with spring strap clamp
- 3 - Spring strap clamp
- 4 - Union nut, 25 Nm
  - counterhold connection fitting in the high pressure pump for loosening
- 5 - Union nut, 25 Nm
  - counterhold connection fitting in the high pressure pump for loosening
- 6 - High pressure pump with fuel pressure regulating valve - N276-
  - removing and installing => [page 174](#)
- 7 - O-ring
  - replace
  - before fitting moisten lightly with clean engine oil
- 8 - Roller tappet
  - before fitting moisten lightly with clean engine oil
- 9 - Connector

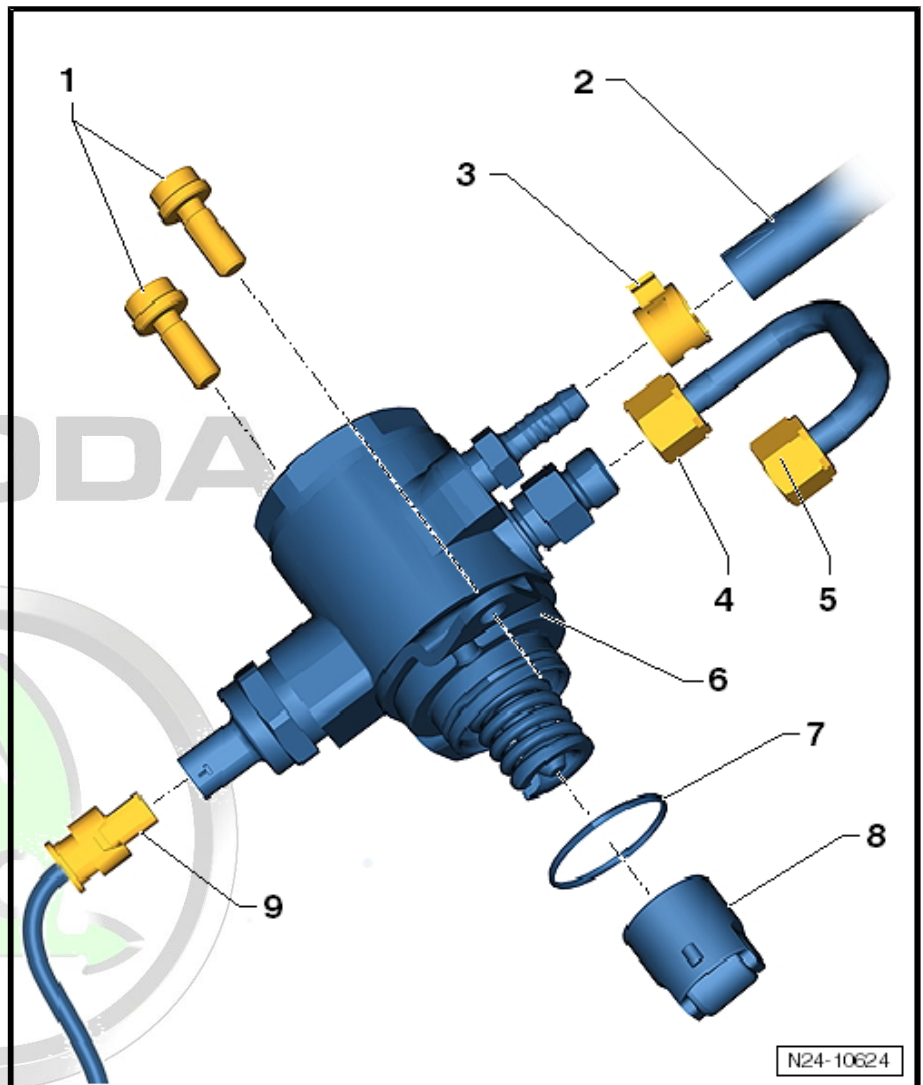



## 4.2 Removing and installing the high pressure pump

### Special tools and workshop equipment required

- ◆ Pliers for spring strap clamps

### Precondition

- The engine must be cold.

### Removing



#### Note

- ◆ *Safety precautions when working on the fuel supply system*  
⇒ [page 3](#).
- ◆ *Rules of cleanliness when working on the fuel supply system*  
⇒ [page 5](#).
- Switch off the ignition and all electrical components and take out the ignition key.



#### WARNING

**The injection system consists of a high pressure part (max. pressure of 12 MPa = 120 bar) and a low pressure part (pressure of approx. 0.6 MPa = 6 bar).**

**Before opening the high pressure area, e.g. removing the high pressure pump, the fuel distributor, the injection valves, the fuel pipes or the fuel pressure sender -G247-, the fuel pressure in the high pressure area with a remaining pressure of approx. 0.6 MPa (6 bar) must be reduced. The procedure for this is described in the chapter „release pressure in the high pressure area of the fuel system“ ⇒ [page 4](#).**



- Disconnect the plug -1- and the fuel feed line -2- from the high pressure pump.

**i** Note

*Collect the fuel which flows out with a cleaning cloth.*

- Slacken the union nuts -3- at the high pressure line.

**i** Note

*Hold the screwed connections at the high pressure pump and at the fuel distributor when slackening the union nuts with a wrench.*

- Uniformly release the fixing screws -4- and remove the high pressure pump with roller tappet from the cylinder head cover.

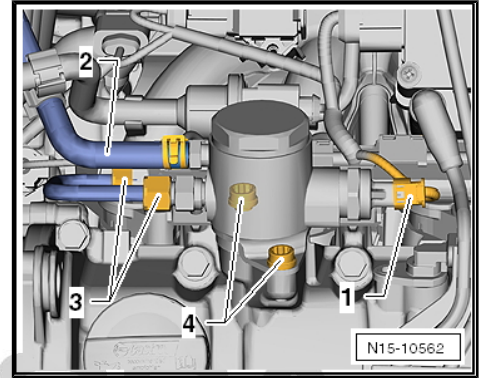

**Install**

**i** Note

◆ *Moisten the roller tappet of the high pressure pump with clean engine oil.*

◆ *Always replace the O-ring of the high pressure pump.*

- Slide the roller tappet -1- into the camshaft housing.
- Insert a new, oiled O-ring -2- into the slot of the high pressure pump -3-.
- Position the high pressure pump -3- on the cylinder head cover.

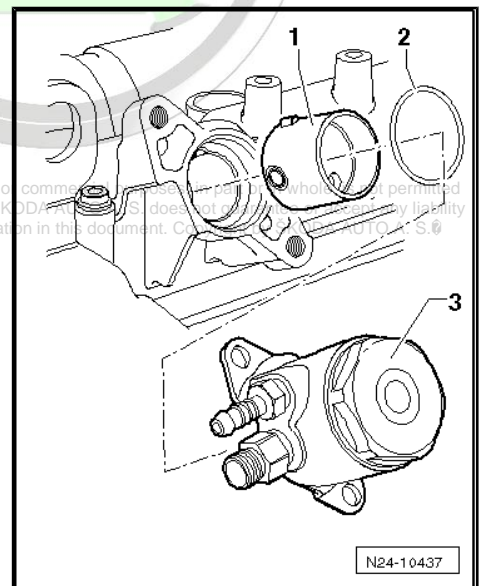

Protected by copyright. Copying for private or commercial purposes without the whole or partial permission unless authorised by ŠKODA AUTO A. S. ŠKODA AUTO A. S. does not grant any liability with respect to the correctness of information in this document. Copyright © ŠKODA AUTO A. S.



- First of all screw in the fixing screws -4- sufficiently until the bolt heads are positioned on the flange.
- Then tighten the fixing screws -4- evenly.  
Tightening torque: 20 Nm
- Screw on the union nuts of the high pressure line -3- by hand.



### Note

*Hold the screwed connections at the high pressure pump and at the bottom part of intake manifold/fuel distributor when tightening the union nuts with a wrench.*

- Tighten the union nuts -3- at the high pressure line to 25 Nm.
- Attach the fuel feed line -2- and the plug -1- on the high pressure pump.

Further installation occurs in a similar way in reverse order to removal.

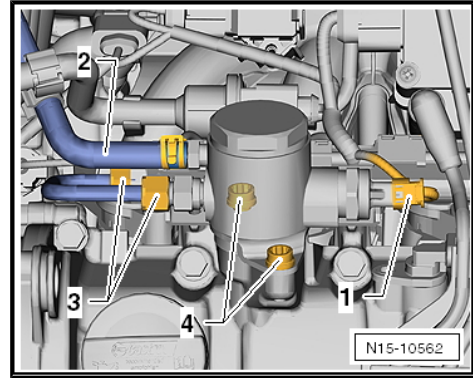

# ŠKODA



## 5 Injection valves

### 5.1 Removing and installing injection valves

#### Note

- ◆ *Safety precautions when working on the fuel supply system*  
⇒ [page 3](#) .
- ◆ *Rules of cleanliness when working on the fuel supply system*  
⇒ [page 5](#) .
- ◆ *Observe the safety instructions before starting fitting work*  
⇒ [page 5](#) .

#### Note

*The Teflon gasket ring on the injection valve must be replaced each time after removing the injection valve* ⇒ [page 179](#) .

#### Special tools and workshop equipment required

- ◆ Set of tools -T10133-

#### Removing

- Release screws -1- and remove retaining clip.
- Disconnect plug -2- at charge pressure sender -G31- with intake air temperature sender 2 -G299 - .
- Release the catches in -direction of arrow- and detach the pressure pipe -3- first of all from the throttle valve control unit -J338 - and then from the exhaust gas turbocharger.
- Remove the high pressure pump ⇒ [page 174](#) .

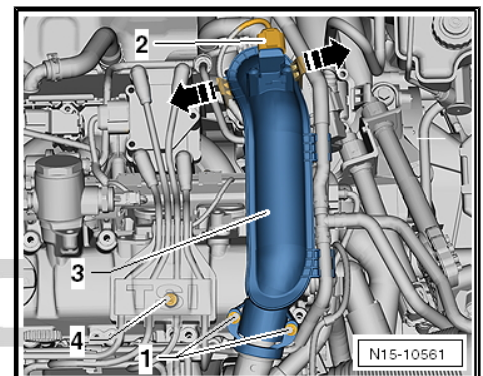

- Release the fixing screws -arrows- and carefully remove the fuel distributor from the injection valves.

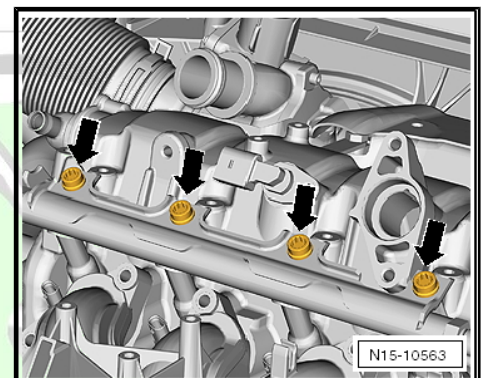



- Press the O-ring upwards by hand as shown and remove it from the injection valve.
- Screw the striking hammer -T10133/3- with the extractor -T10133/15- .

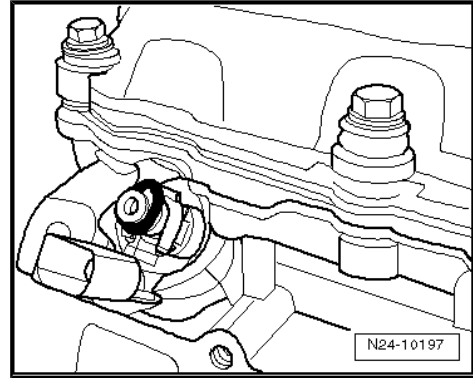

- Then insert the extractor -T10133/15- into the groove -arrow- on the injection valve.

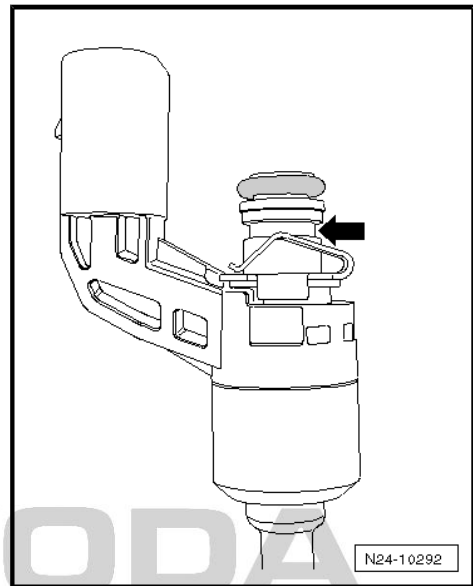

- Pull out the injection valve with careful knocks.

**Install**

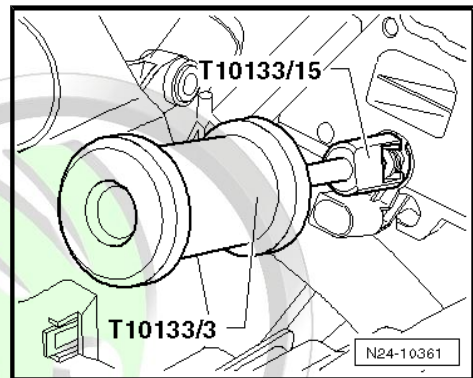

- Thoroughly clean the holes of the injection valves in the cylinder head with the nylon brush -T10133/4- .
- Check the supporting washer made of plastic for damage, replace if necessary ⇒ [page 179](#) .

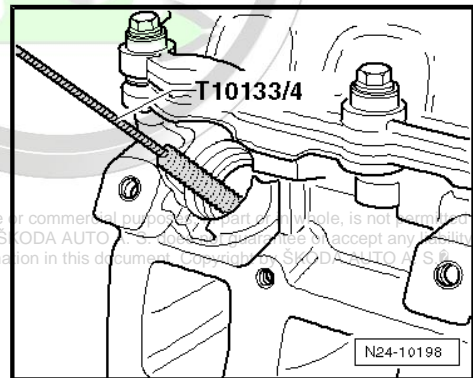

Protected by copyright. Copying for private or commercial purposes without the prior written consent of ŠKODA AUTO A. S. ŠKODA AUTO A. S. does not accept any liability with respect to the correctness of information in this document. Copyright © ŠKODA AUTO A. S. 2010

- Replace the spring element -arrow- as well as the Teflon gasket ring each time after removing the injection valves  
⇒ [page 179](#) .
- Replace O-rings between injection valve and bottom part of the intake manifold/fuel distributor and moisten lightly with clean engine oil.

**i** Note

- ◆ *The Teflon gasket ring of the injection valve must neither be oiled nor greased.*
- ◆ *The injection valve must insert easily, if necessary wait until the gasket ring has been drawn together sufficiently.*

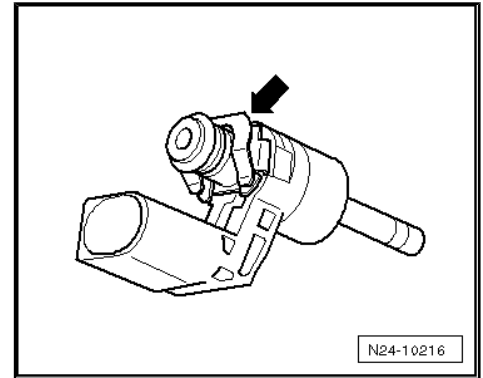

- Press the injection valve -1- by hand up to the stop into the hole of the cylinder head. The injection valve should be pressed evenly into the countersink -2- on the cylinder head.

**i** Note

- ◆ *The injection valve must never rest against the countersink edge on the cylinder head -arrow A-, but it must always be pressed evenly into the countersink -2- on the cylinder head.*
- ◆ *After installing, carry out a visual inspection of the fitting location of the injection valve.*

Further installation occurs in a similar way in reverse order to removal.

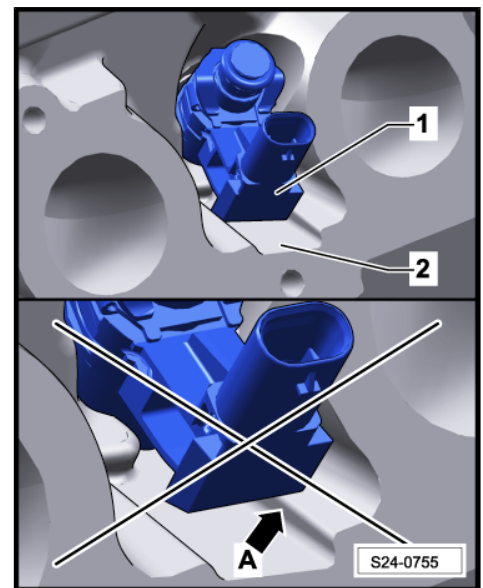

## 5.2 Replace Teflon gasket ring and supporting washer at injection valve

**i** Note

- ◆ *Safety precautions when working on the fuel supply system*  
⇒ [page 3](#) .
- ◆ *Rules of cleanliness when working on the fuel supply system*  
⇒ [page 5](#) .

### Special tools and workshop equipment required

- ◆ Set of tools -T10133-

### Work procedure

#### Replace Teflon gasket ring

- Remove injection valves ⇒ [page 177](#) .
- Carefully clean the injection valve.



- Carefully cut open the gasket ring with a knife as shown -arrow-. Absolutely try to avoid the contact of the knife blade with the valve body.
- Remove the old gasket ring and clean the gasket ring nut in the area of the gasket ring -arrow-. Remove the existing deposits (carbon deposits) with a wire brush.

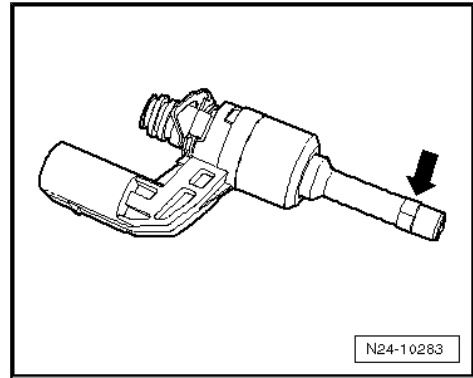

- Fit a new gasket ring -1- onto the assembly cone -T10133/5-. Slightly push the gasket ring with the assembly sleeve -T10133/6- (knurling points to the gasket ring -1-) as far as possible onto the assembly cone -T10133/5- .

ŠKODA

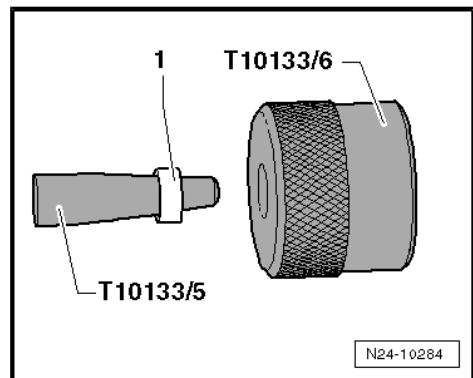

- Turn the assembly sleeve -T10133/6- around (now the knurling points away from the gasket ring), and push the gasket ring -1- up to the end onto the assembly cone -T10133/5- .
- Now position the assembly cone -T10133/5- with the gasket ring from the front onto the injection valve. Push the gasket ring with the assembly sleeve -T10133/6- further onto the injection valve.

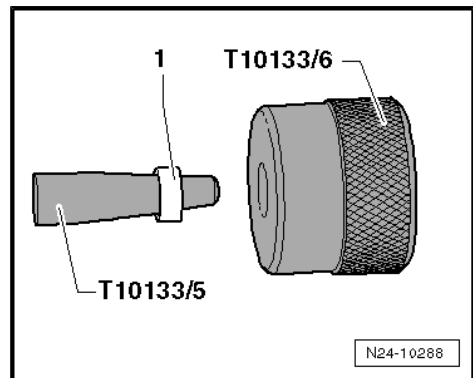

The gasket ring is not yet seated in its groove.

- Remove the assembly sleeve -T10133/6- and the assembly cone -T10133/5- .
- Push the gasket ring by hand into the annular groove.
- Fit the spacer sleeve -T10133/11- onto the valve body.

whole, is not permitted unless authorised by ŠKODA AUTO A. S. ŠKODA AUTO A. S. does not guarantee or accept any liability with respect to the correctness of information in this document. Copyright by ŠKODA AUTO A. S.

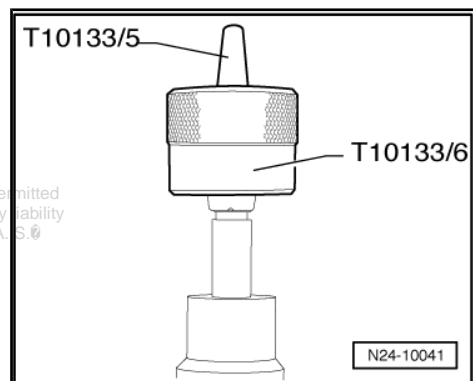

- Now press the calibration sleeve - T10133/7- via the gasket ring up to the stop at the spacer sleeve -T10133/11- .
- Pull off again the calibration sleeve -T10133/7- .

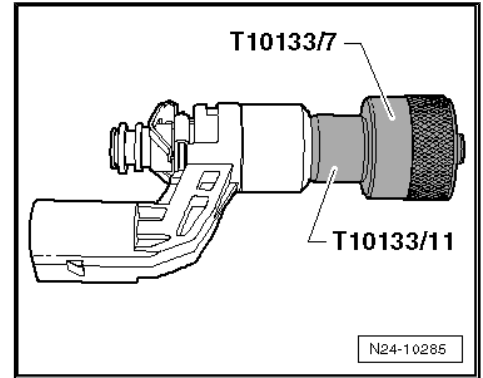

- Now press the calibration sleeve - T10133/8- via the gasket ring up to the stop at the spacer sleeve -T10133/11- .
- Pull off again the calibration sleeve -T10133/8- .

Now the Teflon gasket ring has its correct fitting dimension.

**Replace supporting washer**

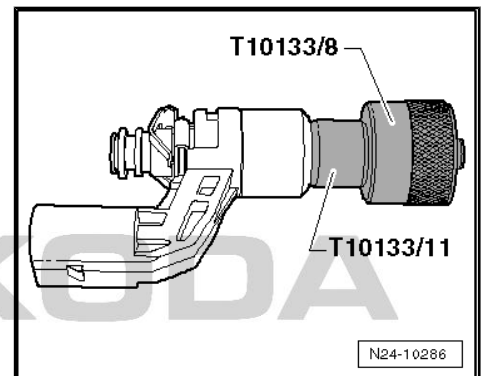

- Remove O-ring -3-.
- Cut open the supporting washer -2- with a small side cutter and take it off.
- Pull off the spring element at the injection valve -1- and instead push on the lock washer -T10133/12 - .

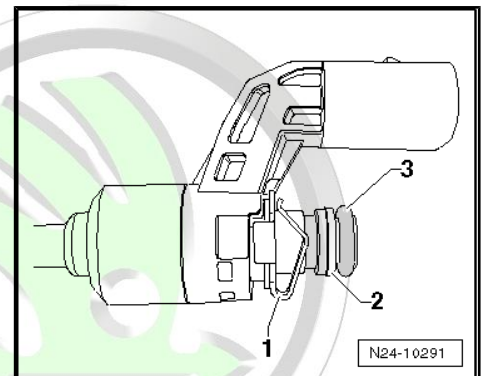

- Mount a new supporting washer -1- on the assembly cone - T10133/13- and fit it onto the injection valve as shown.
- Push the supporting washer -1- with the calibration sleeve - T10133/17- (knurled side points to the injection valve) up to the first nut -arrow- onto the injection valve.

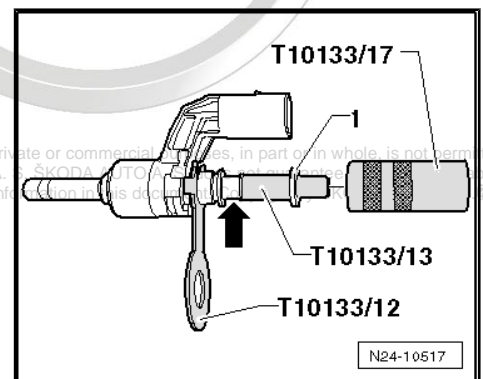

Protected by copyright. Copying for private or commercial purposes, in part or in whole, is not permitted unless authorised by ŠKODA AUTO A.S. ŠKODA AUTO A.S. reserves all rights. ŠKODA AUTO A.S. assumes no liability with respect to the correctness of information in this document.



- Now turn the calibration sleeve -T10133/17 - around (knurled side points away from the injection valve). Push the calibration sleeve via the supporting washer -1- in -direction of arrow- up to the stop on the lock washer -T10133/12- .
- Pull off again the calibration sleeve -T10133/17- .

Now the supporting washer has its correct fitting dimension.

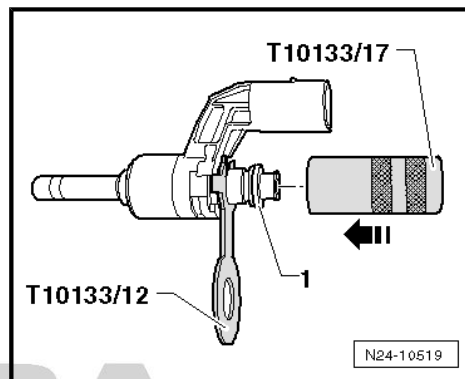

- Now fit a new spring element -1- for the lock washer - T10133/12 - and push a new O-ring -3- in front of the supporting washer -2-.

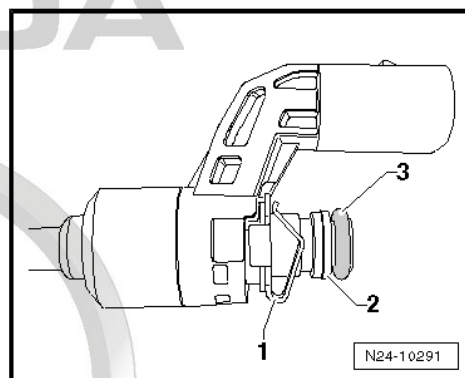

**Note**

*The Teflon gasket ring -arrow- must not be oiled when installing the injection valve.*

- Install injection valves ⇒ [page 177](#) .

Further installation occurs in reverse order to removal.

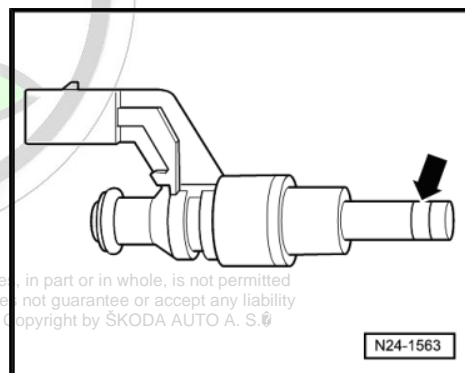

Protected by copyright. Copying for private or commercial purposes, in part or in whole, is not permitted unless authorised by ŠKODA AUTO A. S. ŠKODA AUTO A. S. does not guarantee or accept any liability with respect to the correctness of information in this document. Copyright by ŠKODA AUTO A. S. ©

## 6 Testing components

### 6.1 Check fuel pressure sender -G247-

#### Special tools and workshop equipment required

- ◆ Assembly device -T10118-
- ◆ Open ring spanner with 3/8" drive, wrench size 27 mm
- ◆ Pressure sensor tester , e.g. -VAS 6394- (includes digital manometer -VAS 6394/1- )
- ◆ Adapter , e.g. -VAS 6394/3-
- ◆ Test adapter , e.g. -VAS 5570-
- ◆ Vehicle diagnosis, measurement and information system - VAS 505X-



#### WARNING

*The injection system consists of a high pressure part (max. pressure of 12 MPa = 120 bar) and a low pressure part (pressure of approx. 0.6 MPa = 6 bar).*

*Before opening the high pressure area, e.g. removing the high pressure pump, the fuel distributor, the injection valves, the fuel pipes or the fuel pressure sender -G247- , the fuel pressure in the high pressure area with a remaining pressure of approx. 0.6 MPa (6 bar) must be reduced. The procedure for this is described in the chapter „release pressure in the high pressure area of the fuel system“ ⇒ [page 4](#)*

#### Work procedure

- Disconnect the plug -1- and remove the fuel pressure sender -G247- -1- with the wrench.

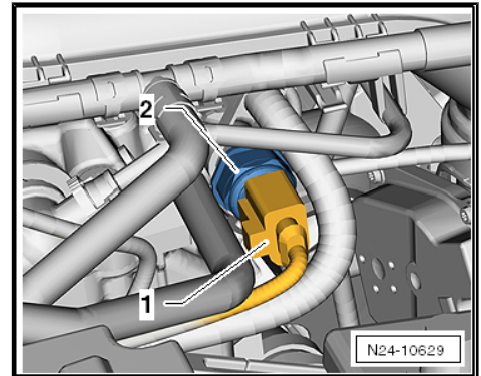

- Moisten the sealing cone of the adapter -VAS 6294/3- with clean engine oil and screw it into the fuel distributor.

Tightening torque: 22 Nm

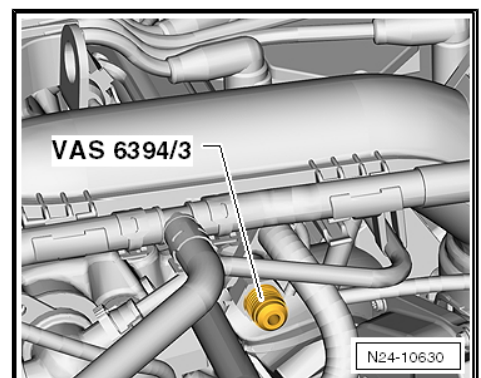



- Release the screw plug -2- and screw the fuel pressure sender -G247- into the tester -VAS 6394/1- .

Tightening torque: 22 Nm

- Screw the pressure line -1- of the digital manometer -VAS 6394/1- by hand onto the adapter -VAS 6394/3- .

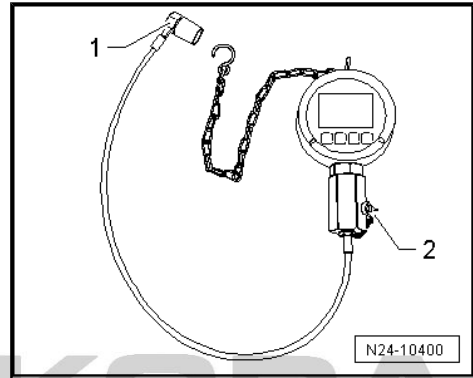

- Connect the test adapter -VAS 5570- to the fuel pressure sender -G247- -1- and to the plug.

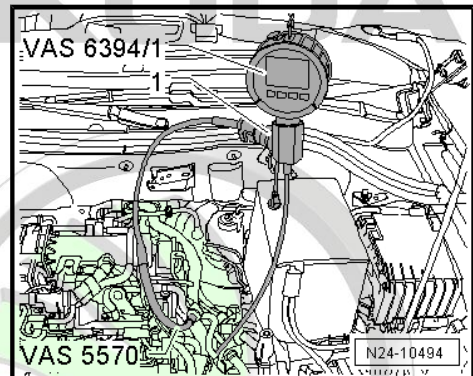

- Switch on the tester -VAS 6394/1 - , for this step, briefly press the button -A- once.



**Note**

- ◆ If the button -A- is pressed for 2 seconds, the illumination is switched on for 20 seconds.
- ◆ If the tester -VAS 6394/1- does not indicate 0 MPa (0 bar), carry out a zero point of the balance by means of the ⇒ operating instructions .

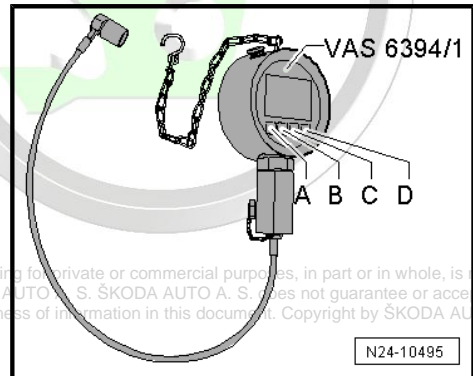

Copyright © by ŠKODA AUTO A. S. ŠKODA AUTO A. S. does not guarantee or accept any liability with respect to the correctness of information in this document. Copyright by ŠKODA AUTO A. S.

- Connect the vehicle diagnosis, measurement and information system -VAS 505X- -1- to the diagnostic connection.
- Switch on ignition.
- On the display press consecutively the following buttons:

Vehicle self-diagnosis

Self-diagnosis ▶

01 - Engine Electronics ▶

011 - Measured values ▶

- Select measured value block **1 4 0** and confirm with **Q**.

The actual value which is transmitted to the vehicle by the fuel pressure sender -G247- is shown in the display field 3.

- Start the engine.
- Compare the displayed pressure on the digital manometer -VAS 6394/1- with the actual value on the vehicle diagnosis, measurement and information system -VAS 505X- .
- The pressures may deviate maximum 0.5 MPa (5 bar) from one another.

If the deviation is greater than 0.5 MPa (5 bar):

- Perform a vehicle diagnosis, measurement and information system -VAS 505X- of the guided function „remove high fuel pressure“.
- Replace fuel pressure sender -G247- .
- Repeat the test with the new fuel pressure sender -G247- and compare both measured values.

**If the measured values do not correspond again:**

- Perform a cable testing ⇒ Vehicle diagnostic, testing and information system VAS 5051.

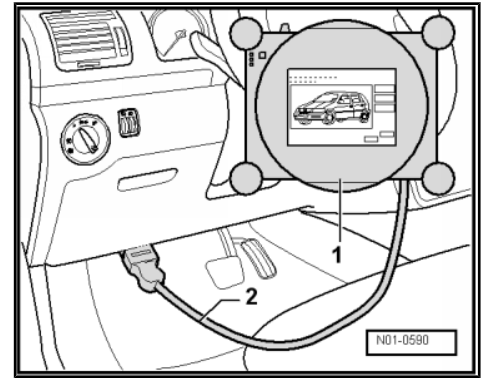

ŠKODA

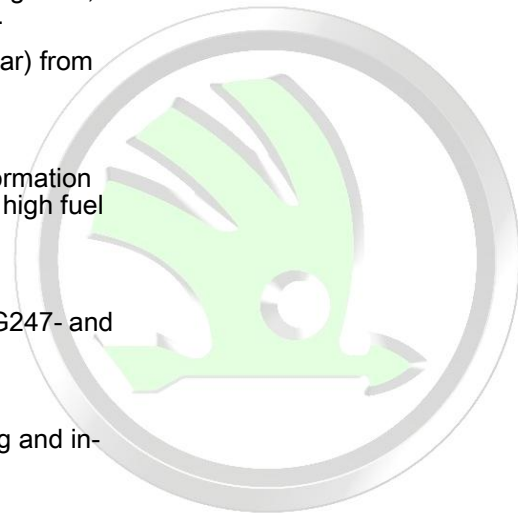

Protected by copyright. Copying for private or commercial purposes, in part or in whole, is not permitted unless authorised by ŠKODA AUTO A. S. ŠKODA AUTO A. S. does not guarantee or accept any liability with respect to the correctness of information in this document. Copyright by ŠKODA AUTO A. S. ©



## 7 Engine control unit

### 7.1 Removing and installing engine control unit

#### Special tools and workshop equipment required

- ◆ Body saw, e.g. -V.A.G 1523 A-



#### Note

- ◆ *In order to unplug the plugs from the control unit, the control unit must always be removed.*
- ◆ *If the engine control unit is replaced, connect the vehicle diagnosis, measurement and information system -VAS 505X- and carry out the function „replace engine control unit“.*

#### Removing

- Switch off ignition.
- Remove the cooling water tank cover ⇒ Body Work ⇒ Rep. gr. 66 .
- Remove bulkhead plenum chamber -arrows-

Protected by copyright. Copying for private use is permitted. ŠKODA AUTO A. S. ŠKODA AUTO A. S. does not guarantee or accept any liability for the content of this document. Copyright by ŠKODA AUTO A. S.

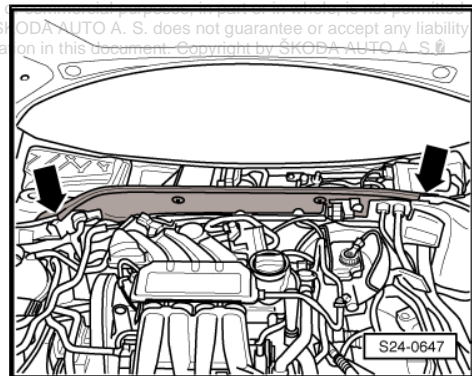

- Open retaining clip -arrow- and remove the engine control unit -J623 - .

#### Vehicles with protective cover

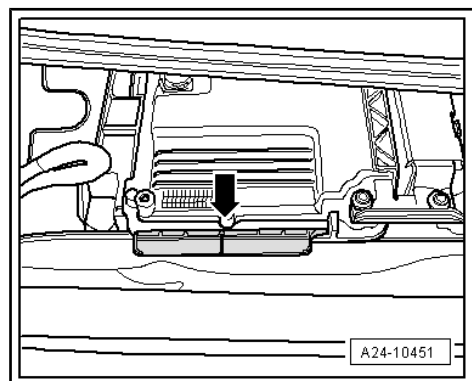

- Cut with body saw a slot for the cross-head screwdriver in the heads of the pull-off screws -3 and 4-

**i** Note

- ◆ *In order to be able to unscrew the screws with a suitable screwdriver, the slot must be wide enough. This is achieved by sawing twice with the body saw.*
- ◆ *The pull-off screws until are inserted with locking agent.*
- Unscrew the screws and remove the protective cover for the plug connections -2 and 5-

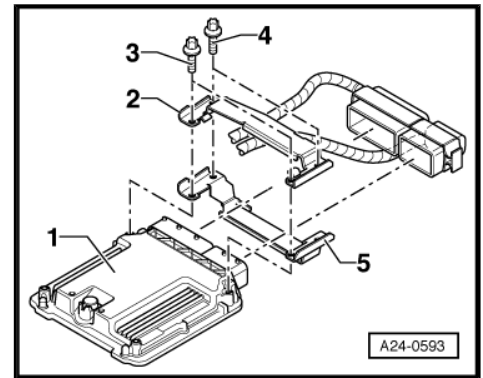

**Continued for all vehicles**

- Unlock both plugs at engine control unit and unplug.

**Install**

- Connect both plugs and lock.

**Vehicles with protective cover**

- Fasten protective cover with new pull-off screws.
- Tighten pull-off screws evenly until the screw heads are pulled off.

**Continued for all vehicles**

- Push engine control unit into the bracket and lock with retaining clip -arrow-.
- Install water box cover ⇒ Body Work ⇒ Rep. gr. 66 .

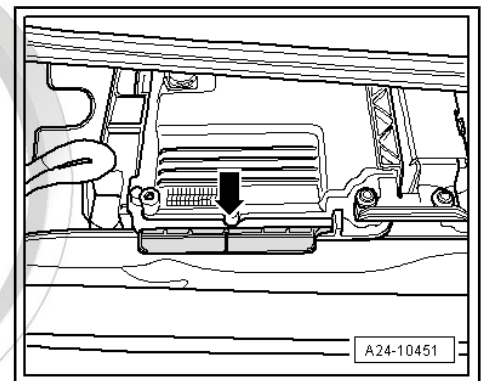

Protected by copyright. Copying for private or commercial purposes, in part or in whole, is not permitted unless authorised by ŠKODA AUTO A. S. ŠKODA AUTO A. S. does not guarantee or accept any liability with respect to the correctness of information in this document. Copyright by ŠKODA AUTO A. S.®



## 26 – Exhaust system

### 1 Removing and installing parts of the exhaust system

#### 1.1 Catalytic converter and component parts - Summary of components

1 - Lambda probe -G39- , 50 Nm

- the thread of new lambda probes must be coated with assembly paste
- for re-used lambda probe, only coat the thread with hot bolt paste -G 052 112 A3- ; the paste must not get into the slots of the probe body

2 - 23 Nm

- replace
- Coat stud bolts of the turbocharger with hot bolt paste -G 052 112 A3- .
- pay attention to mounting instructions and order for tightening  
=> [page 189](#)

3 - Catalytic converter with exhaust pipe

- pay attention to mounting instructions and order for tightening  
=> [page 189](#)

4 - Gasket

- replace

5 - Gasket

- replace

6 - Intermediate pipe

7 - Double clamp, 23 Nm

- Tighten screwed connections uniformly

8 - 25 Nm

- replace

9 - Exhaust pipe

- with decoupling element
- do not twist decoupling element more than 10° - risk of damage
- Secure the decoupling element against over-tensioning and bending by means of the transport security -T10403- .

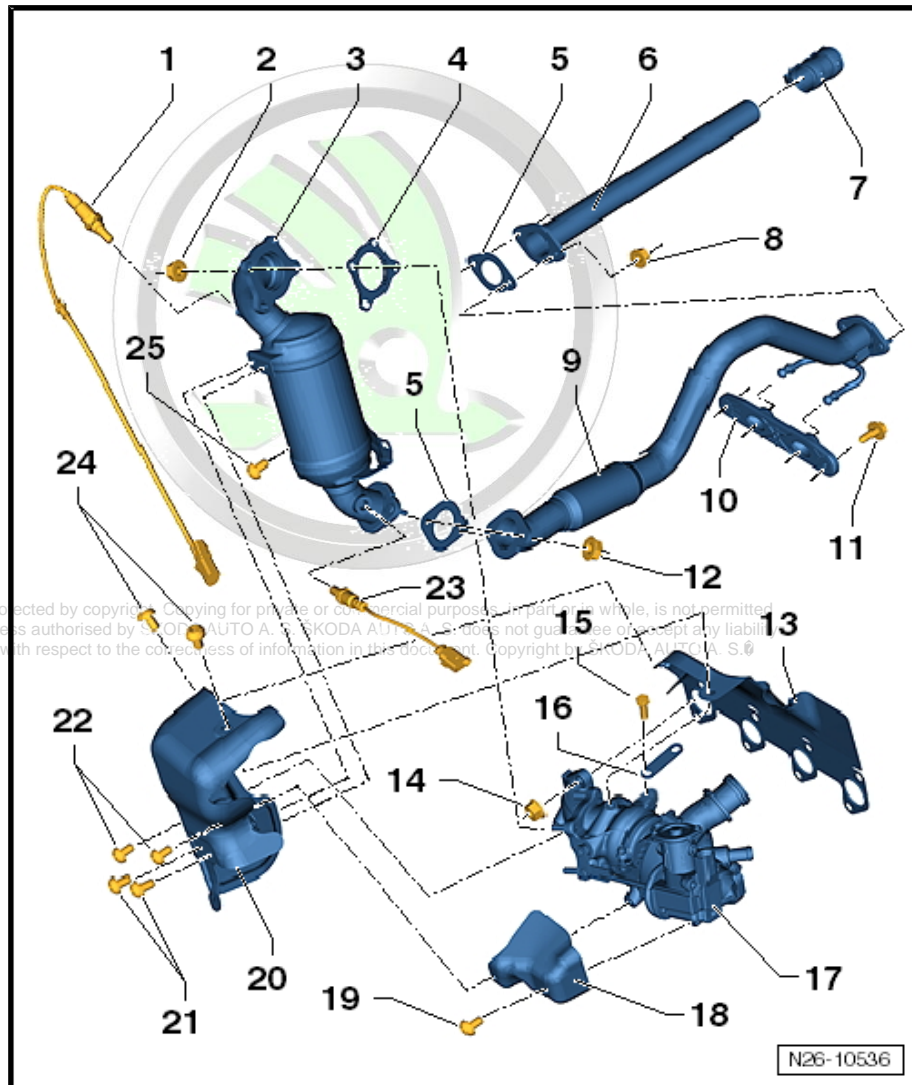

10 - Hanger

11 - 25 Nm

12 - 25 Nm

- replace

13 - Gasket

- replace

14 - 25 Nm

- replace

- Coat pin screws of exhaust pipe with hot bolt paste -G 052 112 A3-

15 - 20 Nm

16 - Support

17 - Exhaust gas turbocharger

- removing and installing => [page 154](#)

- The exhaust gas turbocharger with charge pressure regulator -V465- and exhaust manifold can only be replaced together

18 - Heat shield

19 - 10 Nm

- first of all screw in all fixing screws by hand when installing

20 - Heat shield

21 - 10 Nm

22 - 10 Nm

23 - Lambda probe downstream of catalytic converter -G130- , 50 Nm

- the thread of new lambda probes must be coated with assembly paste

- for re-used lambda probe, only coat the thread with hot bolt paste -G 052 112 A3- ; the paste must not get into the slots of the probe body

24 - 10 Nm

Protected by copyright. Copying for private or commercial purposes, in part or in whole, is not permitted unless authorised by ŠKODA AUTO A. S. ŠKODA AUTO A. S. does not guarantee or accept any liability with respect to the correctness of information in this document. Copyright by ŠKODA AUTO A. S. ©

25 - 25 Nm

- pay attention to mounting instructions and order for tightening => [page 189](#)

### Catalytic converter with exhaust pipe - mounting instructions and order of tightening

Tighten nuts and screws in 4 stages:

Stage	Screws/nuts	Tightening torque
1.	-Arrows-	Tighten nuts by hand up to contact surface.
2.	-1-	25 Nm
3.	-2-	25 Nm
4.	-Arrows-	23 Nm

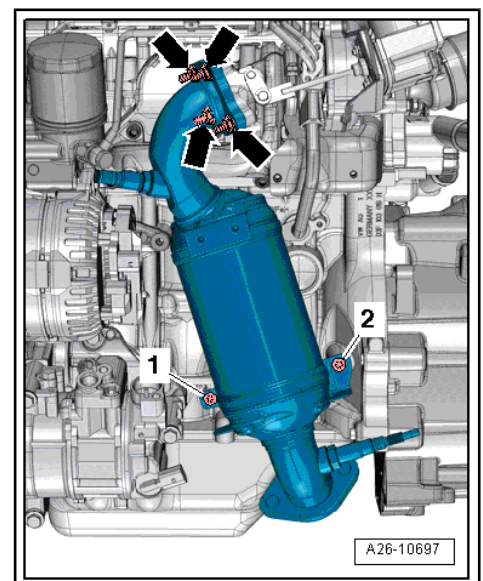



## 1.2 Middle and rear silencer for vehicles manufactured up to 06.10 - Summary of components

### 1 - Hanger

- replace if damaged

### 2 - 23 Nm

### 3 - 20 Nm

### 4 - Tunnel bridge

### 5 - Retaining strap

- replace if damaged

### 6 - Rear silencer

- for first equipment building unit with middle silencer; replace individually when carrying out repairs
- Align exhaust system free of stress  
⇒ [page 192](#)
- Separate the exhaust system ⇒ [page 191](#)

### 7 - Hanger

- replace if damaged

### 8 - The middle silencer

- for first equipment building unit with rear silencer; replace individually when carrying out repairs
- Align exhaust system free of stress  
⇒ [page 192](#)
- Separate the exhaust system ⇒ [page 191](#)

### 9 - Double clamp, 23 Nm

- Tighten screwed connections uniformly
- Fitting position ⇒ [page 191](#)

### 10 - 23 Nm

### 11 - Hanger

- replace if damaged

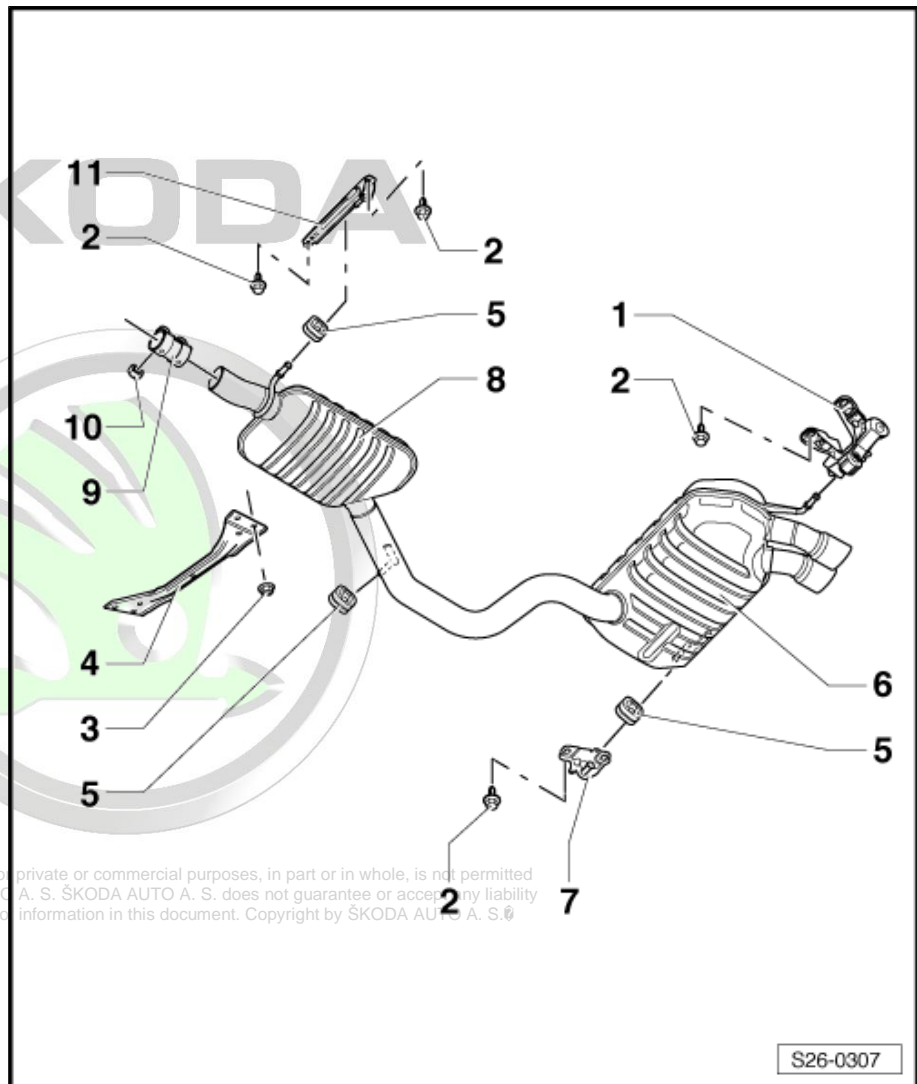

Copying for private or commercial purposes, in part or in whole, is not permitted without the prior written consent of ŠKODA AUTO A. S. ŠKODA AUTO A. S. does not guarantee or accept any liability with respect to the correctness of information in this document. Copyright by ŠKODA AUTO A. S. ©



### 1.3 Middle and rear silencer for vehicles manufactured as of 06.10 - Summary of components

1 - 23 Nm

2 - Hanger

- replace if damaged

3 - Retaining strap

- replace if damaged

4 - Hanger

- replace if damaged

5 - 23 Nm

6 - Rear silencer

- for first equipment building unit with middle silencer; replace individually when carrying out repairs
- Align exhaust system free of stress  
⇒ [page 192](#)
- Separate the exhaust system ⇒ [page 191](#)

7 - Retaining strap

- replace if damaged

8 - Retaining strap

- replace if damaged

9 - The middle silencer

- for first equipment building unit with rear silencer; replace individually when carrying out repairs
- Align exhaust system free of stress  
⇒ [page 192](#)
- Separate the exhaust system ⇒ [page 191](#)

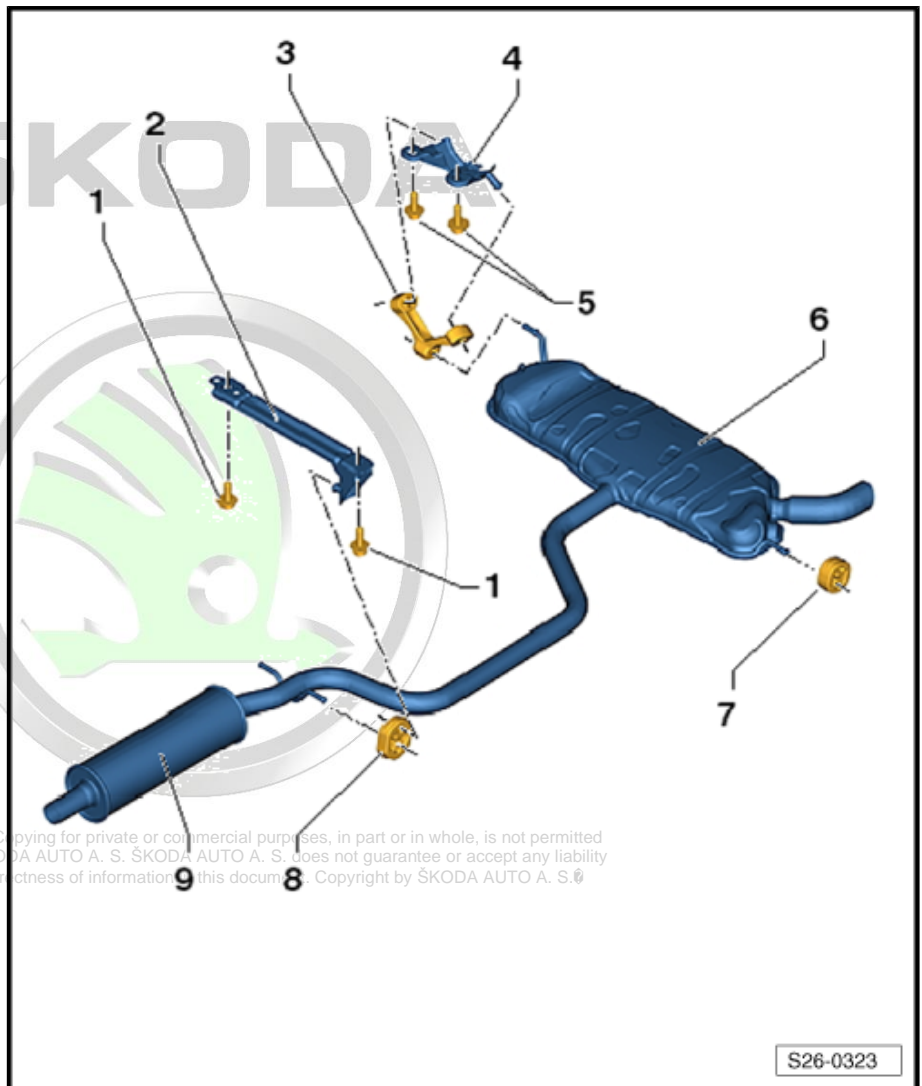

S26-0323

### 1.4 Replacing middle or rear silencer

#### Special tools and workshop equipment required

- ◆ Body saw e.g. -V.A.G 1523 A -
- ◆ Protective goggles

#### Note

- ◆ For individually replacing the front or rear part of the exhaust system, a separation point is provided in the connecting pipe.
- ◆ The separation point is marked by indentations on the circumference of the exhaust pipe.



**WARNING**

*In order to avoid injuries because of metal swarfs, wear safety goggles and safety clothing.*

- Separate exhaust pipe at right angles at the separation point -arrow 2- with body saw.
- When installing, position double clamp -4- at the side markings -arrow 1- and -arrow 3-.

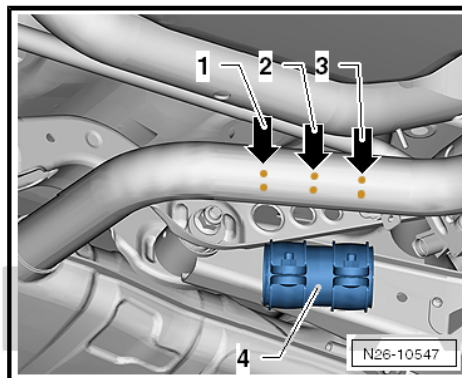

- Turn the double clamp in such a way that the ends of the screws -arrow- do not protrude beyond the bottom edge of the double clamp.
- Align the rear silencer horizontally and tighten the double clamp to 23 Nm.
- Align exhaust system in cold condition free of stress => [page 192](#) .

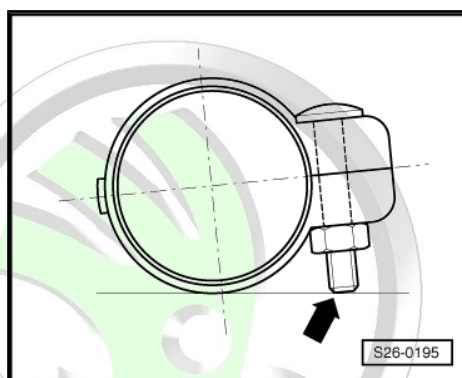

### 1.5 Aligning exhaust system free of stress

- The exhaust system is aligned when cold.
- Slacken the nuts at the double clamp -1- and align the intermediate pipe -2- (-arrow- points in direction of travel).
- a- = 5 mm

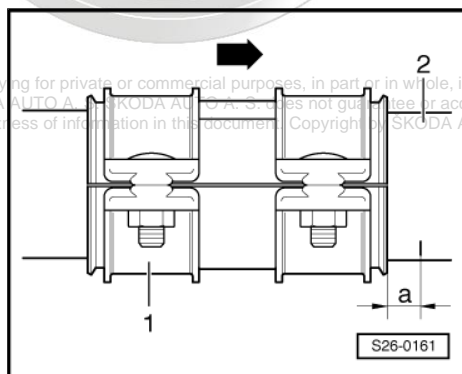

Protected by copyright. Copying for private or commercial purposes, in part or in whole, is not permitted unless authorised by ŠKODA AUTO A. S. ŠKODA AUTO A. S. does not guarantee, or accept any liability with respect to the correctness of information in this document. Copyright © ŠKODA AUTO A. S. 2010



The fixing screws must be located on the right. The screws must not protrude beyond the bottom edge of the double clamp -arrow-.

- Tighten the front nut by hand.

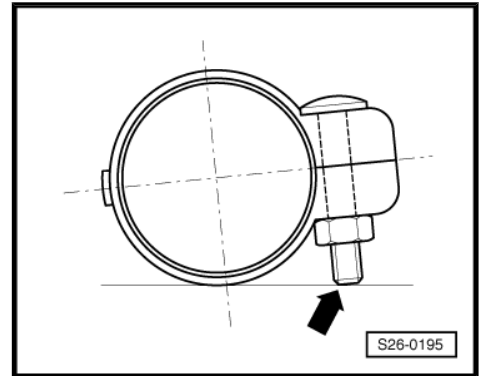

- Push the exhaust system so far forward until the dimension -a- of 7...9 mm is achieved between hanger/body and hanger/middle silencer.
- Tighten bolted connections of the double clamp evenly to 23 Nm.

**Align the exhaust tailpipes for vehicles manufactured up to 06.10.**

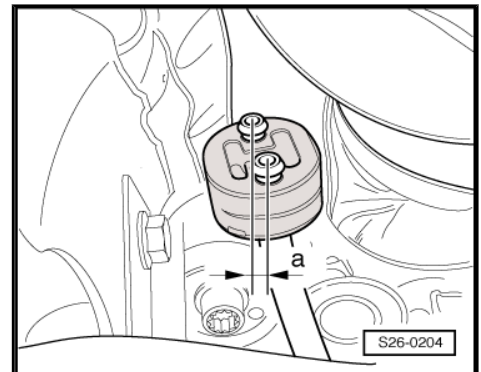

- Align rear muffler in such a way that there is
  - an equal distance -a- between bumper opening and exhaust tailpipe.
  - the distance -b- from the bumper opening to the tailpipes is equal.

For centering, if necessary the hangers of the exhaust system must be loosened.

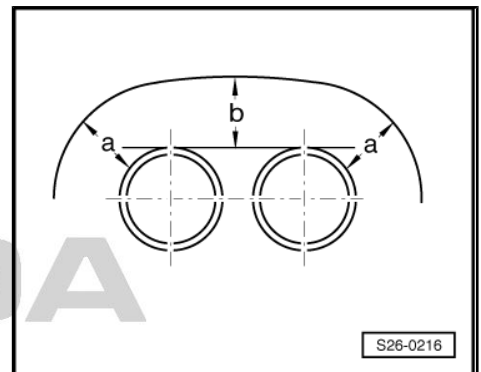

**Align the exhaust tailpipes for vehicles manufactured as of 06.10.**

- Align rear silencer in such a way that there is an equal distance -a- right and left between bumper opening and exhaust tailpipe.
- For centering the exhaust tailpipe, if necessary loosen the suspension of the rear silencer.

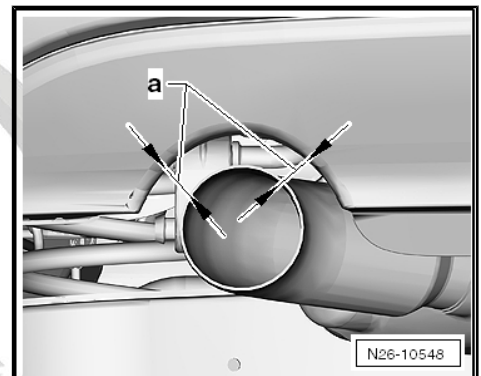

## 1.6 Inspecting the exhaust system for leak-tightness

- Start engine and run in idle.
- Seal off exhaust tailpipes for the duration of the leak check (e.g. with cloth or plug).

Protected by copyright. Copying for private or commercial purposes, in part or in whole, is not permitted. This document is authorised by SKODA AUTO A. S. SKODA AUTO A. S. does not guarantee or accept any liability with respect to the correctness of information in this document. Copyright by SKODA AUTO A. S. ©



- Inspect connection points of cylinder head/exhaust manifold, exhaust gas turbocharger/exhaust pipe etc. for tightness by listening and visual inspection.
- Eliminate any leak found.

# ŠKODA



## 28 – Ignition system

### 1 Ignition system

#### 1.1 Ignition system - Summary of components

1 - Cable guide

2 - 8 Nm

3 - Cap

4 - Connector

5 - Hall sender -G40-

6 - 10 Nm

7 - Ignition cable with spark plug connector

- ❑ Remove the spark plug connector from the spark plugs using the extractor -T10112 A- .

◆ D ignition transformer = ignition cable cyl. 1

◆ B ignition transformer = ignition cable cyl. 2

◆ C ignition transformer = ignition cable cyl. 3

◆ A ignition transformer = ignition cable cyl. 4

8 - Spark plug, 25 Nm



#### Note

- ◆ *When installing new spark plug, the spark plug connectors must be regreased with lubricating paste -G 052 141 A2- . In doing so, the sealing hose of the spark plug connector does not stick to the spark plug. The lubricating paste must spread over the spark plug when fitting on the spark plug connector*  
⇒ [page 196](#) .

- ◆ *The new spark plug cables are supplied greased.*

9 - Knock sensor 1 -G61-

- ❑ at rear cylinder block
- ❑ 20 Nm

10 - Connector

11 - 20 Nm

- ❑ the tightening torque influences the knock sensor function

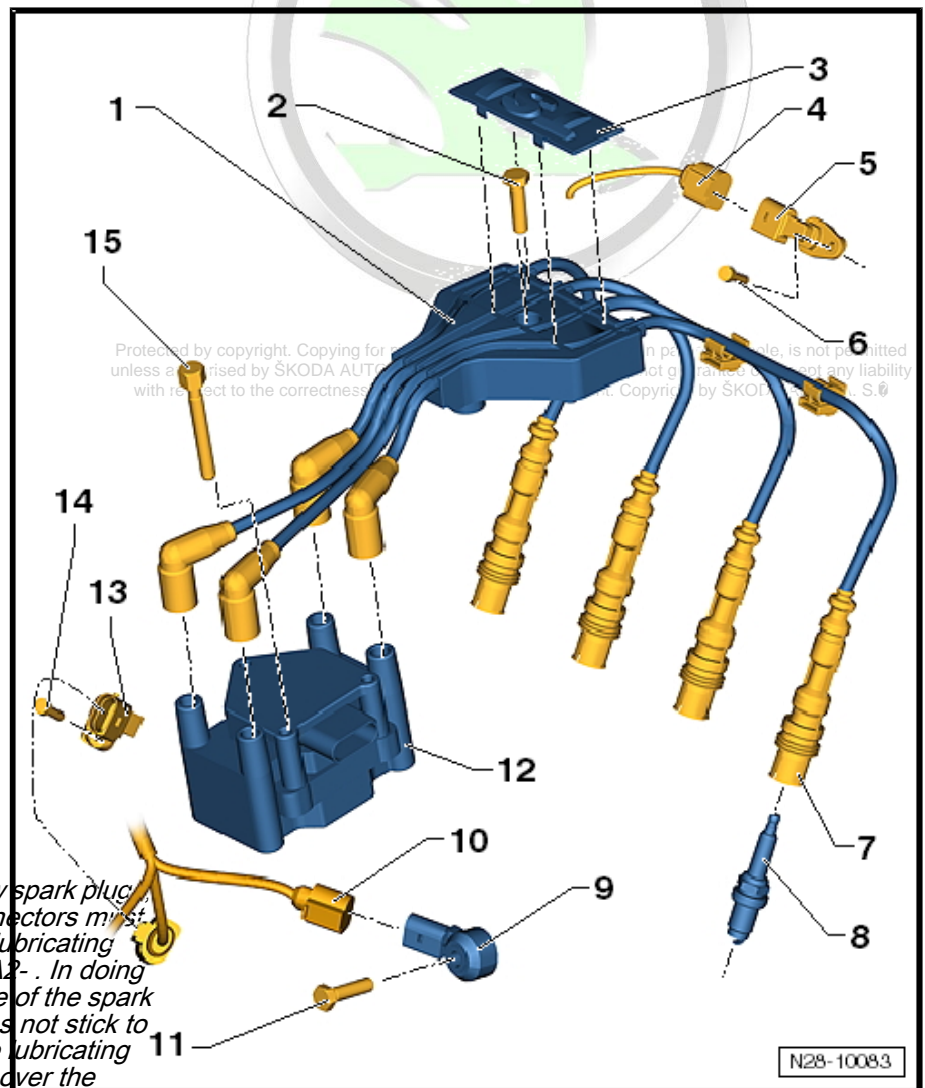



## 12 - Ignition transformer -N152-

- ◆ D ignition transformer = ignition cable cyl. 1
- ◆ B ignition transformer = ignition cable cyl. 2
- ◆ C ignition transformer = ignition cable cyl. 3
- ◆ A ignition transformer = ignition cable cyl. 4

## 13 - Engine speed sender -G28-

- removing and installing ⇒ [page 196](#)

14 - 5 Nm

15 - 7 Nm

## Grease spark plug connector



### Note

*The new spark plug cables are supplied greased.*

- Apply a thin bead of lubricating paste G 052 141 A2 all around the sealing hose of the spark plug connector -arrow-. The bead must be 1...2 mm thick.

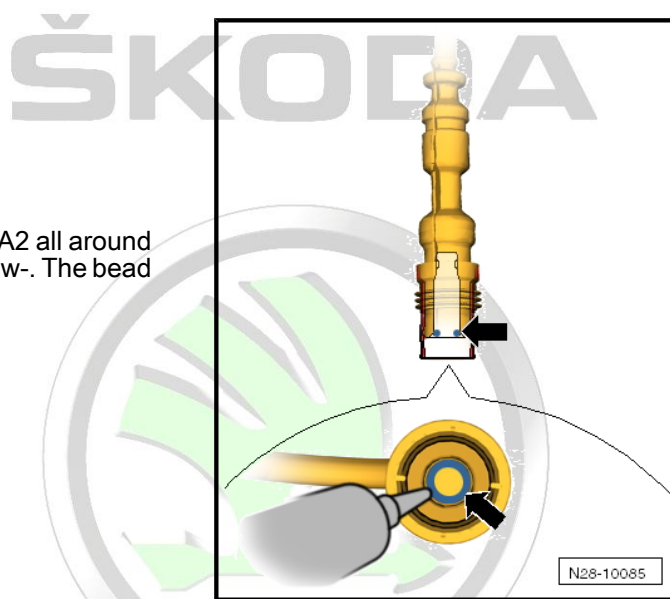

## 1.2 Removing and installing engine speed sender -G28-

### Special tools and workshop equipment required

- ◆ Socket insert -T10370-

### Removing

- Disconnect plug -arrow- from engine speed sender -G28- .
- Unscrew fixing screw of engine speed sender -G28- with socket insert -T10370- .
- Remove engine speed sender -G28- from cylinder block.

### Install

- Install engine speed sender -G28- and tighten the fixing screw to 5 Nm.

Further installation occurs in a similar way in reverse order to removal.

