

# ŠKODA

## Workshop Manual

Yeti 2010 ➤

Yeti 2011 ➤

**Electrical System**

Edition 11.2016



Protected by copyright. Copying for private or commercial purposes, in part or in whole, is not permitted unless authorised by ŠKODA AUTO A. S. ŠKODA AUTO A. S. does not guarantee or accept any liability with respect to the correctness of information in this document. Copyright by ŠKODA AUTO A. S. ©

## List of Workshop Manual Repair Groups

### Repair Group

00 - Technical data

27 - Starter, current supply, CCS

90 - Gauges, instruments

91 - Radio, telephone, navigation

92 - Windscreen wash/wipe system

94 - Lights, bulbs, switches - exterior

96 - Lights, bulbs, switches - interior

97 - Wiring

# ŠKODA



Technical information should always be available to the foremen and mechanics, because their careful and constant adherence to the instructions is essential to ensure vehicle road-worthiness and safety. In addition, the normal basic safety precautions for working on motor vehicles must, as a matter of course, be observed.

## Contents

<b>00 - Technical data</b>	<b>1</b>
<b>1 Safety instructions</b>	<b>1</b>
1.1 Safety precautions when working on vehicles with a start/stop system	1
1.2 Safety precautions during road tests in which testing and measuring equipment is used	1
<b>2 Repair instructions</b>	<b>2</b>
2.1 Contact corrosion	2
2.2 Cable routing and securing	2
<b>3 Battery</b>	<b>4</b>
3.1 Battery types	4
3.2 Basic topics	4
<b>27 - Starter, current supply, CCS</b>	<b>5</b>
<b>1 Battery</b>	<b>5</b>
1.1 Disconnecting and reconnecting battery	5
1.2 Checking the battery	7
1.3 Charging battery	7
1.4 Removing and installing the battery	7
1.5 Removing and installing earth lead with battery monitoring control unit J367	9
1.6 Removing and installing battery carrier	10
1.7 Battery parameterisation	10
<b>2 Starter</b>	<b>12</b>
2.1 Removing and installing the starter	12
<b>3 Generator</b>	<b>14</b>
3.1 Checking generator	14
3.2 Removing and installing alternator	14
3.3 Fixing the B+ wire to the AC generator	19
3.4 Checking the carbon brushes of the AC generator	19
3.5 Removing and installing the Bosch voltage regulator	20
3.6 Removing and installing the Valeo voltage regulator	20
3.7 Removing and installing poly V-belt pulley	21
<b>4 "Start-stop" system</b>	<b>27</b>
4.1 Safety precautions for vehicles with "start-stop" system	27
4.2 General description	27
4.3 Fault recognition and fault display	28
4.4 Battery recharging or starting by external source on vehicles with "start-stop system"	28
4.5 Replacing the battery on vehicles with "start-stop" system	28
4.6 Voltage stabilizer J532	29
4.7 Battery monitoring control unit J367	30
4.8 Button for "start-stop" system	30
<b>90 - Gauges, instruments</b>	<b>31</b>
<b>1 Dash panel insert</b>	<b>31</b>
1.1 General description	31
1.2 Adjust/replace dash panel insert	32
1.3 Removing and installing the dash panel insert	32
1.4 Warning lights in the dash panel insert	33
1.5 Service interval display	34
1.6 The self-diagnostic function of the dash panel insert	34
<b>2 Cruise control system (CCS)</b>	<b>36</b>
<b>91 - Radio, telephone, navigation</b>	<b>37</b>
<b>1 Radio</b>	<b>37</b>



1.1	General Instructions	37
1.2	Electronic anti-theft coding	37
1.3	Overview of radio system	38
1.4	Removing and installing a radio	40
1.5	Self-diagnostic function of radio system	42
<b>2</b>	<b>Navigation system Amundsen and Columbus</b>	<b>43</b>
2.1	General description	43
2.2	General Instructions	44
2.3	Electronic anti-theft coding	44
2.4	Overall view of the navigation system	45
2.5	Removing and installing the navigation system	47
2.6	Self-diagnosis of the navigation system	48
<b>3</b>	<b>Telephone system</b>	<b>49</b>
3.1	General points	49
3.2	Universal mobile phone pre-installation GSM II	50
3.3	Universal mobile phone pre-installation GSM III	51
3.4	Removing and installing the microphone for the telephone R38	51
3.5	Removing and installing the mount for the mobile phone	51
3.6	Removing and installing the control unit for the mobile phone operating electronics J412	52
<b>4</b>	<b>Aerial systems</b>	<b>54</b>
4.1	Overview of the aerial systems	54
4.2	Roof aerial for radio	56
4.3	Roof aerial for radio, telephone and navigation system	56
4.4	Removing and installing aerial module R108	57
4.5	Removing and installing the GPS aerial under the dash panel	58
4.6	Replacing aerial cables	58
<b>5</b>	<b>Multi-functional steering wheel</b>	<b>59</b>
5.1	General description	59
5.2	Multifunctional steering wheel up to MY 2013	60
5.3	Multifunctional steering wheel as of MY 2014	61
5.4	Diagnosis of the multi-functional steering wheel	63
<b>6</b>	<b>Sound system</b>	<b>64</b>
6.1	General description	64
6.2	Removing and installing the control unit for the digital sound package J525	64
6.3	Contact assignment of the 38-pin plug connection for amplifier	66
6.4	Removing and installing loudspeakers	67
<b>7</b>	<b>Loudspeaker system</b>	<b>68</b>
7.1	Removing and installing the front and rear bass speaker	68
7.2	Removing and installing the front midrange speaker	68
7.3	Removing and installing the rear midrange speaker	69
7.4	Removing and installing the front and rear treble speaker	69
<b>8</b>	<b>CD changer</b>	<b>70</b>
8.1	Removing and installing CD changer	70
8.2	Plug connection on the CD changer	70
<b>9</b>	<b>Connection for external audio sources R199</b>	<b>71</b>
9.1	General description	71
9.2	Removing and installing the connection for external audio sources R199	71
<b>10</b>	<b>Multimedia socket MEDIA-IN (MDI) with control unit for multimedia system J650</b>	<b>73</b>
10.1	General description	73
10.2	Removing and installing multimedia socket	73
10.3	Removing and installing the control unit for multimedia system J650	73
<b>11</b>	<b>SmartLink system</b>	<b>75</b>
11.1	General points	75



<b>12</b>	<b>SmartGate system</b>	<b>76</b>
12.1	General points	76
12.2	SmartGate system - check the correct function	77
12.3	Remove and install control unit for information electronics 2 J829 (SmartGate)	78
12.4	Set the parameters for the Wi-Fi connection	79
12.5	Update firmware	80
<b>13</b>	<b>Mobile services online, ERA Glonass system</b>	<b>82</b>
13.1	General information, ERA Glonass system	82
13.2	Installation location overview, ERA Glonass	82
13.3	Removing and installing control unit for emergency call module and communication unit J949	83
13.4	Removing and installing emergency call button E276	84
13.5	Removing and installing power speaker for emergency call module R335	84
13.6	Replacing battery for control unit for emergency call module and communication unit J949	85
13.7	Replacing and adapting control unit for emergency call module and communication unit J949, vehicles for Russia, Belarus and Kazakhstan	85
13.8	Checking that the components and communication of the ERA Glonass system are functioning	87
<b>92</b>	<b>Windscreen wash/wipe system</b>	<b>89</b>
<b>1</b>	<b>Windscreen washer system</b>	<b>89</b>
1.1	Check function	89
1.2	Remove and install reservoir, pumps and sensor for washer fluid level	89
1.3	Removing and installing the spray nozzles for windscreen washer system	90
1.4	Removing and installing the spray nozzle for rear window washer system	91
1.5	Repairing washer fluid lines	92
<b>2</b>	<b>Windscreen wiper system</b>	<b>93</b>
2.1	General description	93
2.2	Removing and installing the wiper arms with wiper blades and setting their final setting	93
2.3	Removing and installing wiper motor with linkage	95
2.4	Removing and installing the wiper motor from the wiper frame	95
2.5	Removing and installing Sensor for rain and light detection	97
2.6	Repairing the humidity, rain and light detection sensor	101
<b>3</b>	<b>Rear window wiper system</b>	<b>105</b>
3.1	Removing and installing the windscreen wiper arm and setting its final position	105
3.2	Removing and installing rear window wiper motor	105
<b>4</b>	<b>Headlamp cleaning system</b>	<b>107</b>
4.1	Removing and installing headlight cleaning system pump V11	107
4.2	Removing and installing the lift cylinder for spray nozzles of headlight	107
4.3	Bleed the headlamp cleaning system	107
<b>94</b>	<b>Lights, bulbs, switches - exterior</b>	<b>109</b>
<b>1</b>	<b>Headlights - halogen headlights</b>	<b>109</b>
1.1	Summary of components headlight - vehicles up to MY 2013	109
1.2	Summary of components headlight - vehicles as of MY 2014	111
1.3	Removing and installing headlight	111
1.4	Adjusting headlights	113
1.5	Replacing light bulbs in the headlight - vehicles up to MY 2013	113
1.6	Replacing light bulbs in the headlight - vehicles as of MY 2014	117
1.7	Change headlight for right-hand / left-hand traffic	122
1.8	Replace headlight fixing brackets	124
1.9	Removing and installing headlight range control motor	125
<b>2</b>	<b>Headlights with Xenon discharge lamps</b>	<b>128</b>
2.1	General description	128
2.2	Fault recognition and fault display	129



2.3	Summary of components headlight - vehicles up to MY 2013	129
2.4	Summary of components headlight - vehicles as of MY 2014	131
2.5	Removing and installing headlight	132
2.6	Adjusting headlights	132
2.7	Replacing light bulbs in the headlight - vehicles up to MY 2013	132
2.8	Replacing light bulbs in the headlight - vehicles as of MY 2014	134
2.9	Remove and install performance module for the headlight J667 left or J668 right	136
2.10	Removing and installing Control unit for daylight driving light and side light left J860 and J861 right	138
2.11	Removing and installing control unit for gas discharge lamp J343 left or J344 right	138
2.12	Removing and installing headlight range control motor	139
2.13	Change headlight for right-hand / left-hand traffic	141
2.14	Removing and installing the cornering light and headlight range control unit J745	141
2.15	Vehicle level sensor front left G78 and rear left G76	142
2.16	Replace headlight fixing brackets	142
<b>3</b>	<b>Fog light with corner function - as of MY 2014</b>	<b>143</b>
3.1	Removing and installing fog light	143
3.2	Replacing the light bulb for fog light "H8"	144
3.3	Adjusting the fog light	145
<b>4</b>	<b>Tail lights</b>	<b>146</b>
4.1	Removing and installing the tail light	146
4.2	Removing and installing lamp holder	146
4.3	Summary of components of light bulbs	147
<b>5</b>	<b>Number plate light</b>	<b>148</b>
5.1	Removing and installing number plate light	148
<b>6</b>	<b>High level brake light</b>	<b>149</b>
6.1	Removing and installing high level brake light	149
<b>7</b>	<b>Steering column switch</b>	<b>150</b>
7.1	Self-diagnosis, coding and fault indication	150
7.2	Steering column switch - installed up to 05.2010	150
7.3	Steering column switch - installed as of 06.2010	156
7.4	Setting middle position of the return ring with coil spring	159
<b>8</b>	<b>Steering lock with ignition starter switch and lock cylinder</b>	<b>161</b>
8.1	Removing and installing lock cylinder	161
8.2	Removing and installing steering lock - installed up to 05.2010	162
8.3	Removing and installing steering lock - installed as of 06.2010	163
8.4	Removing and installing the ignition/starter switch	163
8.5	Removing and installing ignition key anti-removal lock solenoid N376	164
8.6	Contact assignment on the ignition/starter switch and the ignition key anti-removal lock	165
<b>9</b>	<b>Keyless unlocking of the vehicle/the steering, keyless start/stop – interface for entry and start system</b>	<b>166</b>
9.1	General description	166
9.2	Fault recognition and fault display	166
9.3	Summary of components of the interface for entry and start system	166
9.4	Removing and installing control unit for entry and start authorisation J518	168
9.5	Aerials of the interface for entry and start system	169
9.6	Removing and installing start/stop button and immobiliser reader coil for emergency start	171
9.7	Steering lock with control unit for electronic steering column lock J764 (ESCL)	172
<b>10</b>	<b>Parking aid and park steering assistant</b>	<b>173</b>
10.1	General description	173
10.2	Fault recognition and fault display	173
10.3	Summary of components	174
10.4	Remove and install parking aid control unit J446 or parking aid and park steering assistant control unit J791	175



10.5	Remove and install the front parking aid warning buzzer H22	175
10.6	Removing and installing the rear parking aid warning buzzer H15	176
10.7	Removing and installing front parking aid sender	177
10.8	Removing and installing rear parking aid sender	177
10.9	Removing and installing the park steering assistant sender	178
10.10	Parking aid sender holder and park steering assistant - making holes, assignment, fitting position, gluing procedure	178
<b>11</b>	<b>Optical parking assistant (rear view camera)</b>	<b>181</b>
11.1	General description	181
11.2	Summary of components: Rear view camera system	181
11.3	Removing and installing rear view camera system	182
11.4	Removing and installing the rear view camera spray nozzle	183
<b>12</b>	<b>Door entry lighting in the exterior mirror</b>	<b>185</b>
12.1	Removing and installing door entry lighting and replacing light bulb	185
<b>13</b>	<b>Side turn signal in the exterior mirror</b>	<b>186</b>
13.1	Removing and installing the turn signal light in the exterior mirror	186
<b>96</b>	<b>Lights, bulbs, switches - interior</b>	<b>187</b>
<b>1</b>	<b>Lights and switches in the roof cover</b>	<b>187</b>
1.1	Removing and installing the front interior light	187
1.2	Replace light bulbs for front interior light	187
1.3	Removing and installing the sliding roof switch	188
1.4	Removing and installing the interior light for the tail end of the vehicle	188
<b>2</b>	<b>Lights and switches in the dash panel</b>	<b>190</b>
2.1	Removing and installing light switch	190
2.2	Removing and installing the headlight range control adjuster	190
2.3	Removing and installing switches in centre console	191
2.4	Removing and installing hazard warning lights button	191
2.5	Removing and installing the warning light for front passenger airbag switch-off function	192
2.6	Removing and installing glove box light	192
<b>3</b>	<b>Lights and switches in the centre console</b>	<b>194</b>
3.1	Removing and installing switch for inside actuation of the central locking	194
<b>4</b>	<b>Interior lights and switches</b>	<b>195</b>
4.1	Removing and installing interior monitoring deactivation switch E267 and deactivation button for vehicle inclination sender E360	195
<b>5</b>	<b>Lights and switches in the door</b>	<b>196</b>
5.1	Removing and installing the switch for the power window lifter	196
5.2	Removing and installing the mirror adjustment switch	196
5.3	Removing and installing the switch for the power windows on the front and rear passenger's side	197
5.4	Removing and installing door warning lamp	197
<b>6</b>	<b>Lights and switches in the luggage compartment</b>	<b>199</b>
6.1	Removing and installing luggage compartment light	199
6.2	Removing and installing luggage compartment light - removable lamp	199
6.3	Removing and installing the tailgate release switch	200
6.4	Removing and installing the tailgate release control motor	200
<b>7</b>	<b>Anti-theft warning system</b>	<b>201</b>
7.1	General points	201
7.2	Alarm horn H12	201
7.3	Removing and installing the contact switch for the bonnet F266	202
7.4	Removing and installing interior monitoring deactivation switch E267 and deactivation button for vehicle inclination sender E360	203
7.5	Removing and installing interior monitoring sensor G273 and vehicle inclination sender G384	203
<b>8</b>	<b>Horn</b>	<b>204</b>



8.1	Removing and installing high-tone horn and low-tone horn	204
<b>9</b>	<b>12V sockets</b>	<b>206</b>
9.1	Removing and installing the 12 V socket in the centre console	206
9.2	Removing and installing the luggage compartment 12 V power socket	207
<b>10</b>	<b>Immobiliser</b>	<b>208</b>
10.1	General points	208
10.2	Immobiliser control unit J362	208
10.3	Adapting and checking the ignition key	209
10.4	New identity when changing all the components	209
10.5	System test result (online connection)	210
<b>97 - Wiring</b>		<b>211</b>
<b>1</b>	<b>Fuse holder and relay carrier</b>	<b>211</b>
1.1	Removing and installing fuse holder in the dash panel	211
1.2	Removing and installing the relay carrier below the vehicle voltage control unit J519	212
1.3	Removing and installing the relay carrier above the vehicle voltage control unit J519	213
1.4	Removing and installing the E-box in the engine compartment (relay and fuse holder)	213
<b>2</b>	<b>Control units</b>	<b>217</b>
2.1	Onboard supply control unit J519	217
2.2	Data bus diagnostic interface Gateway J533	218
<b>3</b>	<b>Vehicle diagnosis, measurement and information systems</b>	<b>221</b>
<b>4</b>	<b>Wiring harness repair</b>	<b>222</b>
<b>5</b>	<b>Repairing socket housings and connectors</b>	<b>223</b>
<b>6</b>	<b>Repairing optical fibres</b>	<b>224</b>
<b>7</b>	<b>Contact surface cleaning set VAS 6410</b>	<b>225</b>

## 00 – Technical data

### 1 Safety instructions

(SRL001017; Edition 11.2016)

⇒ [“1.1 Safety precautions when working on vehicles with a start/stop system”, page 1](#)

⇒ [“1.2 Safety precautions during road tests in which testing and measuring equipment is used”, page 1](#)

#### 1.1 Safety precautions when working on vehicles with a start/stop system

When working on vehicles with start/stop system, please observe the following:



##### WARNING

*Risk of injury from automatic engine start.*

- ◆ *On vehicles with activated start-stop system (recognizable by a message in the dash panel insert) there is a risk that the engine can start automatically.*
- ◆ *It is therefore necessary to ensure that the start-stop system is deactivated when carrying out work on the vehicle (switch ignition off, if required switch ignition on again).*

#### 1.2 Safety precautions during road tests in which testing and measuring equipment is used

Note the following if testers and measuring instruments are used during road tests:



##### WARNING

*There is a risk of accident from insufficient securing of testers and measuring instruments.*

*There is a hazard from the release of the passenger airbag in the event of an accident.*

- *Drivers operating testing and measuring equipment while driving can lead to an accident.*
- *Increased risk of accident due to unsecured test and measuring devices.*

*Always secure the testing and measuring equipment with a belt on the rear seat and have a second person operate them there.*



## 2 Repair instructions

⇒ "2.1 Contact corrosion", page 2

⇒ "2.2 Cable routing and securing", page 2

### 2.1 Contact corrosion

The use of unsuitable connection elements (screws, nuts, washers, etc.) causes contact corrosion.

This is why only connection elements with a special surface coating are fitted.

Therefore, the rubber or plastic parts and the adhesives are made from electrically non-conductive materials.

In case of doubt regarding the re-use of certain parts, the use of new parts is recommended.



#### Caution

- ◆ *It is recommended to use only original connection material as well as spare parts which are tested and compatible with aluminium, see ⇒ Electronic Catalogue of Original Parts "ETKA".*
- ◆ *It is recommended to use only Škoda accessories.*
- ◆ *Any damage resulting from contact corrosion is not covered by the terms of the warranty.*

### 2.2 Cable routing and securing



#### Caution

**Risk of damage to cables, risk of fire and failure of onboard electrical system!**

- ◆ *To rule out mix ups and ensure the original fitting position, mark the lines before disassembly. This includes lines for fuel, hydraulics, underpressure, activated charcoal filter, or electric cables. Make photos or sketches where necessary.*
- ◆ *To prevent damage to lines, sufficient clearance from all moving or hot components must be ensured in the engine compartment due to its cramped construction.*
- ◆ *All plug connections must be locked using catches, if necessary with special securing clips, to prevent them disconnecting unintentionally. When connecting, the catches must engage audibly; for plug connections with catch, lock the plug connection by pushing in the catch. If necessary, check it is locked correctly by pulling gently on the plug connection.*

#### Example of a connector catch with special securing clip -1-

Primary voltage supply in the relay and fuse carrier under the dash panel:

Protected by copyright. Copying for private or commercial purposes, in part or in whole, is not permitted without the prior written consent of ŠKODA AUTO A. S. ŠKODA AUTO A. S. does not guarantee or accept any liability with respect to the correctness of information in this document. Copyright by ŠKODA AUTO A. S. ©

 Note

- ◆ After connecting the plug -2- to terminal 30+ on the relay and fuse carrier -3-, secure the plug connection by pushing the securing clip -1- in -direction of arrow- up to the stop!
- ◆ Check it is locked correctly by pulling gently on the plug connection.

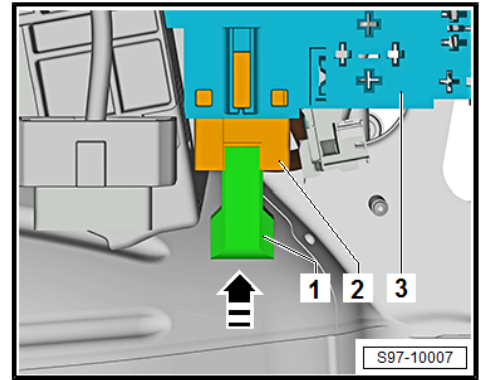

# ŠKODA



Protected by copyright. Copying for private or commercial purposes, in part or in whole, is not permitted unless authorised by ŠKODA AUTO A. S. ŠKODA AUTO A. S. does not guarantee or accept any liability with respect to the correctness of information in this document. Copyright by ŠKODA AUTO A. S. ©



## 3 Battery

⇒ [“3.1 Battery types”, page 4](#)

⇒ [“3.2 Basic topics”, page 4](#)

### 3.1 Battery types



#### WARNING

*When working on the battery wear proper protection and observe safety precautions (see “Electrical System - General notes” ⇒ [Electrical System - General notes; Rep. gr. 27 Section “27”](#)). If a note cannot be accessed, open the Workshop Manual “Electrical System - General Notes” manually in “ELSA”.*

Batteries with a magic eye and plugs covered in adhesive tape are factory-installed in all vehicles (except vehicles with start-stop system).

In vehicles with start/stop system, (depending on types of engines see ⇒ [Electronic Catalogue of Original Parts “ETKA”](#)), a fleece battery (AGM) or a battery with magic eye with EFB technology (Enhanced Flooded Battery) is installed.

The AGM battery is also installed in vehicles with auxiliary heating and additional heating.

Description of the function, test and maintenance of the previous batteries see “Electrical System – General notes” ⇒ [Electrical System – General notes; Rep. gr. 27](#). If a note cannot be accessed, open the Workshop Manual “Electrical System - General Notes” manually in “ELSA”.

Copying for private or commercial purposes, in part or in whole, is not permitted unless authorised by ŠKODA AUTO A. S. ŠKODA AUTO A. S. does not guarantee or accept any liability for the correctness of information in this document. Copyright by ŠKODA AUTO A. S. ©

### 3.2 Basic topics



#### WARNING

*When working on the battery wear proper protection and observe safety precautions (see “Electrical System - General notes” ⇒ [Electrical System - General notes; Rep. gr. 27](#)).*

## 27 – Starter, current supply, CCS

### 1 Battery

- ⇒ [“1.1 Disconnecting and reconnecting battery”, page 5](#)
- ⇒ [“1.2 Checking the battery”, page 7](#)
- ⇒ [“1.3 Charging battery”, page 7](#)
- ⇒ [“1.4 Removing and installing the battery”, page 7](#)
- ⇒ [“1.5 Removing and installing earth lead with battery monitoring control unit J367”, page 9](#)
- ⇒ [“1.6 Removing and installing battery carrier”, page 10](#)
- ⇒ [“1.7 Battery parameterisation”, page 10](#)

#### 1.1 Disconnecting and reconnecting battery

- ⇒ [“1.1.1 Disconnect battery”, page 5](#)
- ⇒ [“1.1.2 Reconnecting battery”, page 6](#)

##### 1.1.1 Disconnect battery

Protected by copyright. Copying for private or commercial purposes, in part or in whole, is not permitted without the express written consent of ŠKODA AUTO A. S. ŠKODA AUTO A. S. does not guarantee or accept any liability for the completeness or correctness of information in this document. Copyright by ŠKODA AUTO A. S.

##### Note

Query the code of the radio or navigation system before disconnecting the battery. This does not apply for radio and navigation systems installed at the works see [“1.2 Electronic anti-theft coding”, page 37](#).

- Switch off all electrical components and take out the ignition key.
- Depending upon vehicle equipment - remove the battery cover -1-, to do so press the release button -arrow-, or lift off the polyester cover of the battery.

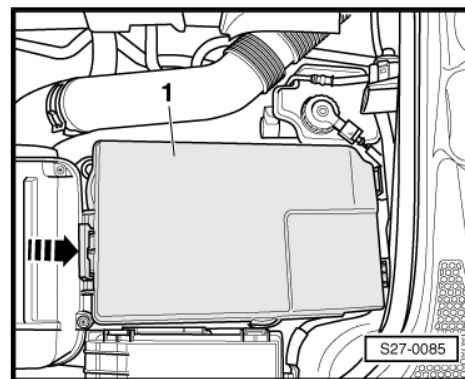

- Slacken nut and only disconnect battery earth strap -1-.

##### Note

If both terminals are disconnected, only then disconnect the pole terminal (-) -1- and subsequently the pole terminal (+) -2-.

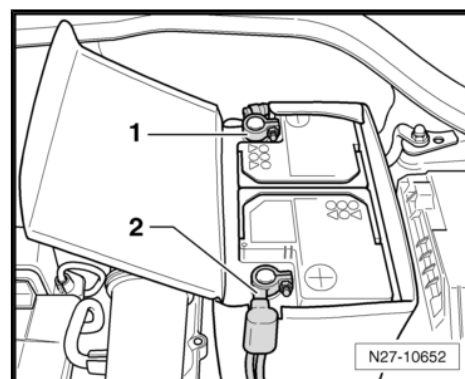



## 1.1.2 Reconnecting battery



### WARNING

*Please observe the following additional instructions after working on the airbag system or on the belt tighteners or the safety belts:*

- ◆ *Switch on the ignition before connecting the battery.*
- ◆ *Nobody should be in the vehicle when the battery is being connected.*
- ◆ *If the vehicle is equipped with the interface for entry and start system (Kessy), the ignition should only be switched on after connecting the battery using the ⇒ Vehicle diagnostic tester outside the vehicle cockpit (the valid ignition key must be inside the vehicle) for safety reasons. This procedure is part of the tests in the targeted fault finding.*



### Note

- ◆ *Neither grease nor oil the battery terminals.*
  - ◆ *The battery pole terminals must only be fitted by hand without using any force in order to avoid damaging the battery housing.*
  - ◆ *Install the battery pole terminals in such a way that the battery poles with the terminals are on the same level or protrude.*
  - ◆ *If both terminals are disconnected, only then disconnect the battery positive pole terminal (+).*
  - ◆ *After connecting the battery and switching on the ignition, the warning light for the stability program TCS/ESP and the warning light for the power-assisted steering remain lit. The warning lights go out automatically after driving a few metres forward. Thereby the steering angle sender - G85- is activated again.*
- Switch off all electrical components and take out the ignition key.

### Vehicles with battery monitoring control unit - J367- (with start-stop system)

- Disconnect the plug -3- from the control unit -2- before connecting to the battery.
- Fit pole terminal (-) with control unit onto the “-” pole of the battery, see fig., and tighten the fixing nut -1-.
- Fit the plug -3- again onto the control unit.

### Vehicles without battery monitoring control unit - J367-

Protected by copyright. Copying for private or commercial purposes, in part or in whole, is not permitted unless authorised by ŠKODA AUTO A. S. ŠKODA AUTO A. S. does not guarantee or accept any liability with respect to the correctness of information in this document. Copyright by ŠKODA AUTO A. S. ©

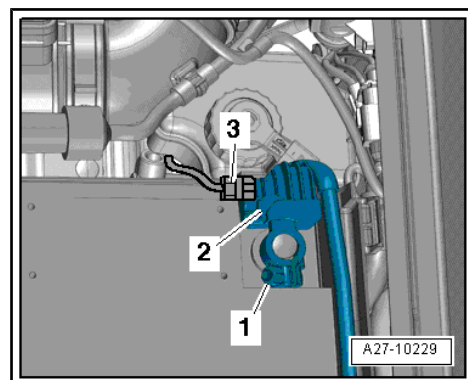



- Fit battery clamp of the earth cable to the battery negative terminal and tighten the nut -arrow-.

**Continued for all vehicles:**

When the battery is reconnected, perform the following operations depending on the vehicle equipment:

- ◆ Set clock.
- ◆ Check the power windows => Maintenance ; Booklet Yeti .
- ◆ Radio/navigation with anti-theft coding (not valid for radio systems/navigation systems assembled at the factory, see => **“1.2 Electronic anti-theft coding”, page 37** ) => operating manual of the radio system/navigation system .
- ◆ Connect the => Vehicle diagnostic tester, interrogate the event memory and delete any event entries.

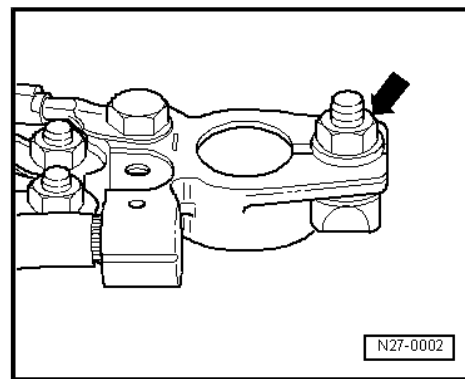

**Tightening torques**

Battery-earth strap to battery terminal	6 Nm
Positive cable to battery terminal	6 Nm

**1.2 Checking the battery**

All the notes and comments to the work procedure for checking the battery can be found in the Workshop Manual “Electrical System – General notes” => Electrical System – General notes; Rep. gr. 27 .

**1.3 Charging battery**

All other notes and comments to this chapter can be found in the Workshop Manual “Electrical System – General notes” => Electrical System – General notes.; Rep. gr. 27

**1.4 Removing and installing the battery**



**WARNING**

*When working on the battery wear proper protection and observe safety precautions (see “Electrical System - General notes” => Electrical System - General notes; Rep. gr. 27 ).*

**Removing**

- Switch off all electrical components and take out the ignition key.
- Disconnect the earth cable and then the positive terminal of the battery  
 => **“1.1 Disconnecting and reconnecting battery”, page 5** .



- Screw out the fixing screws of the upper cover for air suction -1- (2 Nm) and fold away to the side. Protect the air filter with the cover to prevent any dirt from penetrating.

Battery in polyester housing - after disconnecting the terminals -arrows- pull the polyester housing -2- out of the battery towards the top.

- Unscrew bolt -4-.
- Remove the retaining clamp -3- and take out the battery.

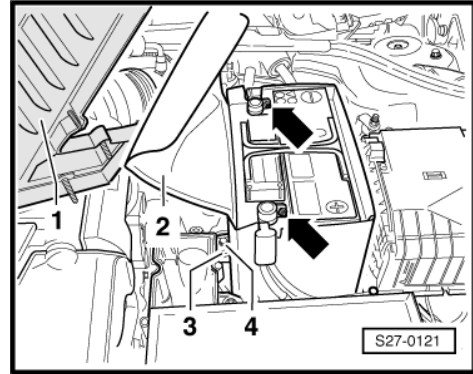

Battery in polyester housing - pull the front of the battery housing upwards -arrow-.

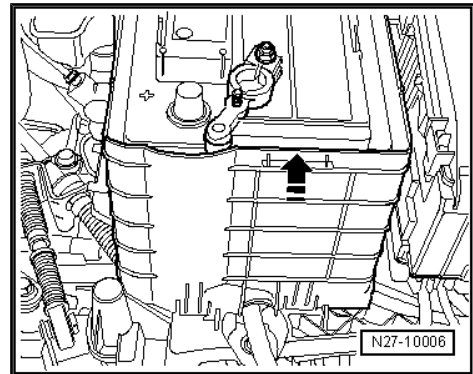

ŠKODA

- Unscrew bolt -1-.
- Remove the retaining clamp -2- and take out the battery.

**Install**

Installation is performed in the reverse order, pay attention to the following points:

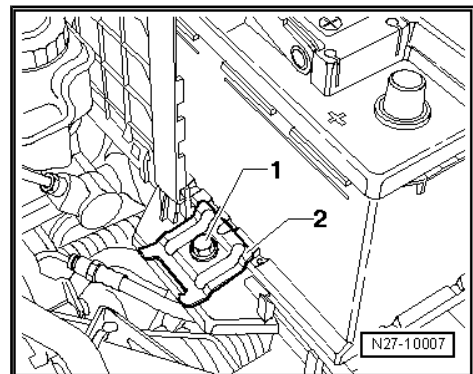
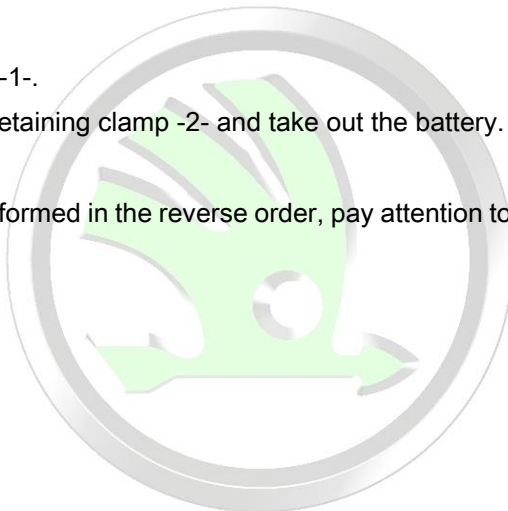

Protected by copyright. Copying for private or commercial purposes, in part or in whole, is not permitted unless authorised by ŠKODA AUTO A. S. ŠKODA AUTO A. S. does not guarantee or accept any liability with respect to the correctness of information in this document. Copyright by ŠKODA AUTO A. S. ©



- The battery is properly installed when the middle recess of the front battery foot strip is aligned at the bottom with the bore in the battery tray -arrows-.
- Observe the instructions after reconnecting the battery  
 ⇒ "1.1 Disconnecting and reconnecting battery", page 5 .

**Caution**

*There are certain dangers if the battery is incorrectly mounted or mounted loosely:*

- ◆ *A shortened working life due to damage from shaking (risk of explosion).*
- ◆ *Damage to the grid plates of the battery.*
- ◆ *Damage to the battery housing from the mounting bracket (possibility of acid leaking out leading to high subsequent costs).*
- ◆ *Inadequate crash safety.*

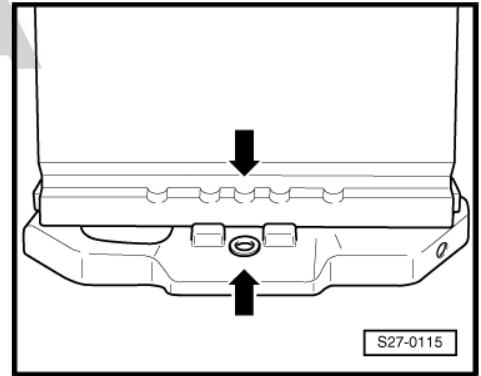

#### Tightening torques

Battery-earth strap to battery terminal	6 Nm
Positive cable to battery terminal	6 Nm
Mounting bracket for battery	22 Nm

## 1.5 Removing and installing earth lead with battery monitoring control unit - J367-

### Removing

- Switch off all electrical components and take out the ignition key.
- Undo nuts -1- and remove the pole terminal with the control unit -3- from the battery-cable terminal.
- Unplug connector -2-.

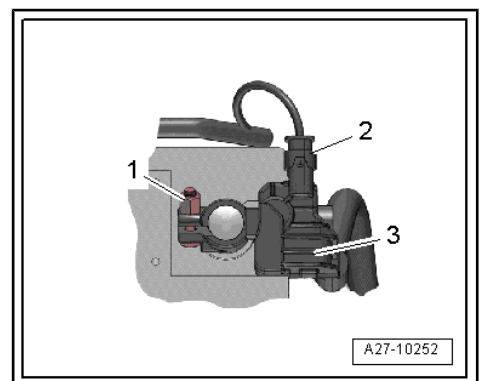



- Unscrew the nuts -2- and remove the earth cable -1- with battery monitoring control unit - J367- .

**Install**

Installation is performed in the reverse order, pay attention to the following points:

- Pay attention to the work sequence when connecting the battery ⇒ [“1.1 Disconnecting and reconnecting battery”, page 5](#) .
- Adapt the battery monitoring control unit - J367- ⇒ [“1.7 Battery parameterisation”, page 10](#) .

**Tightening torques**

Battery-earth strap to battery terminal	6 Nm
Nut, Pos. -2-	15 Nm

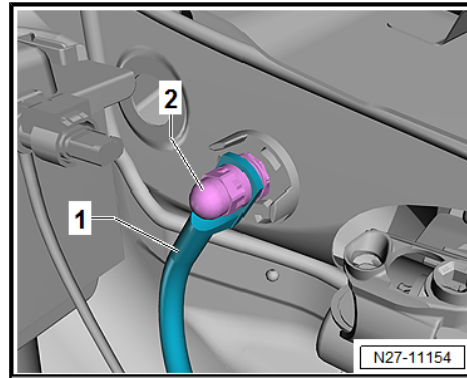

**1.6 Removing and installing battery carrier**

**Removing**

- Remove air filter housing ⇒ Engine; Rep. gr. 23 diesel engines or ⇒ Engine; Rep. gr. 24 petrol engines.
- Remove the battery ⇒ [“1.4 Removing and installing the battery”, page 7](#) .
- Unscrew the screws -arrows- and remove the battery tray.

**Install**

Installation is performed in the reverse order, pay attention to the following points:

**Tightening torques**

Screws -arrows-	9 Nm
-----------------	------

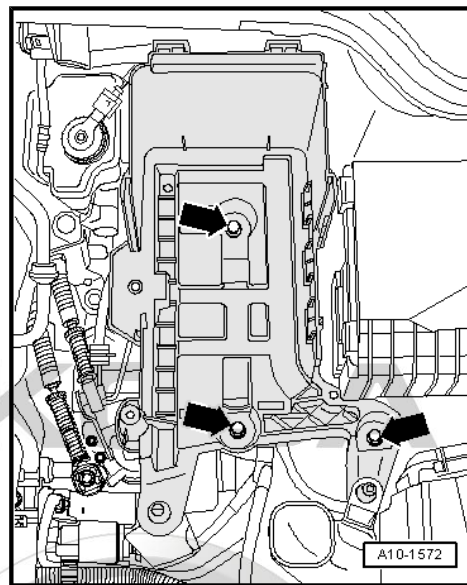

**1.7 Battery parameterisation**

It is performed on vehicles with a start-stop system when replacing the battery with a new one of another type or with higher capacity.

After a new start battery is installed and the battery has been parameterised, the technical data of the new battery are sent to the battery monitoring control unit - J367- .

- ⇒ Vehicle diagnostic tester connect and select the operating mode “Targeted fault-finding”.
- Select the “Selected Functions/Components” and subsequently the following menu points using the button “Skip”:

- ◆ Body
- ◆ Electrical System



- ◆ Diagnostic capable systems
- ◆ Checking the battery
- ◆ Battery monitoring function
- ◆ Adaption battery parameterisation

# ŠKODA



Protected by copyright. Copying for private or commercial purposes, in part or in whole, is not permitted unless authorised by ŠKODA AUTO A. S. ŠKODA AUTO A. S. does not guarantee or accept any liability with respect to the correctness of information in this document. Copyright by ŠKODA AUTO A. S. ©

## 2 Starter

⇒ "2.1 Removing and installing the starter", page 12

### 2.1 Removing and installing the starter

#### Removing

- Disconnect battery earth strap  
⇒ "1.1 Disconnecting and reconnecting battery", page 5 .
- Remove air filter housing ⇒ Engine; Rep. gr. 23 diesel engines or ⇒ Engine; Rep. gr. 24 petrol engines.
- Move the protective cover -arrow-.

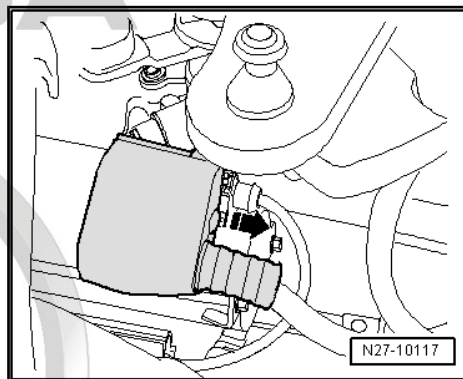

- Unscrew nut -3- and disconnect positive cable.
- Unlock the plug connection -2- and disconnect.
- Depending on equipment - release nut -1- and loosen battery earth strap.

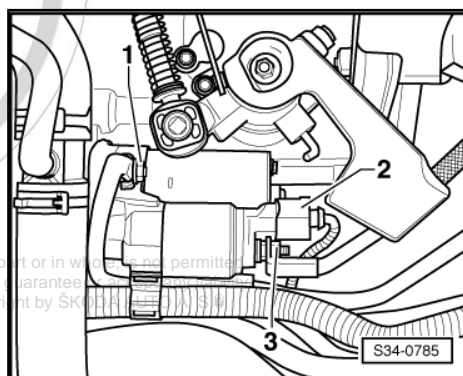

Protected by copyright. Copying for private or commercial purposes, in part or in whole, is not permitted without the prior written consent of ŠKODA AUTO A. S. ŠKODA AUTO A. S. does not guarantee the accuracy of the information in this document. Copyright by ŠKODA AUTO A. S.

- Then screw out top fixing screw for starter -arrow-.

Vehicles fitted with a manual gearbox:

- Remove the sound dampening system ⇒ Body Work; Rep. gr. 50 .

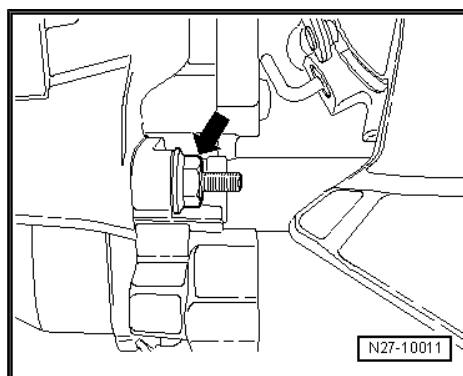



- Unscrew nut -1- and lay aside line holder -2- together with the line.

All vehicles:

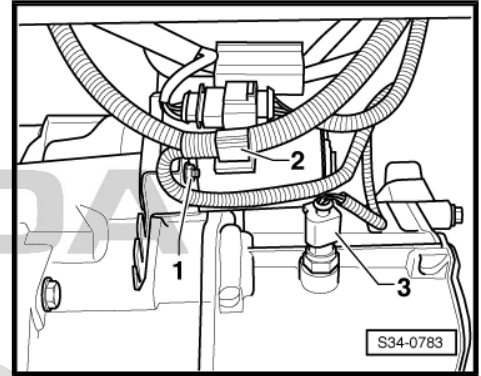

- Screw out bottom fixing screw -arrow- and remove the starter.

### Install

Installation is performed in the reverse order, pay attention to the following points:

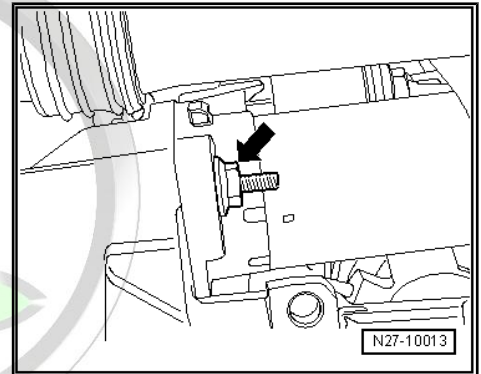

**Caution**

**Risk of short-circuit and fire!**

*The line to terminal B+ on the starter must be laid and attached so that it does not come into contact with rotating or moving parts of the assembly (e.g. with the shift mechanism, with rotating parts of the assembly etc.)!*

*In an incorrect cable/cable attachment to terminal B+ can cause cable damage, a short-circuit and a vehicle fire.*

Protected by copyright. Copying for private or commercial purposes, in part or in whole, is not permitted unless authorised by SKODA AUTO A. S. SKODA AUTO A. S. does not guarantee or accept any liability with respect to the correctness of information in this document. Copyright by SKODA AUTO A. S. ©

**Note**

Use new self-locking nuts -1- and -3- for attaching the earth strap and the positive cable, see ⇒ *Electronic Catalogue of Original Parts* .

- Pay attention to the work sequence when connecting the battery ⇒ [“1.1 Disconnecting and reconnecting battery”, page 5](#) .

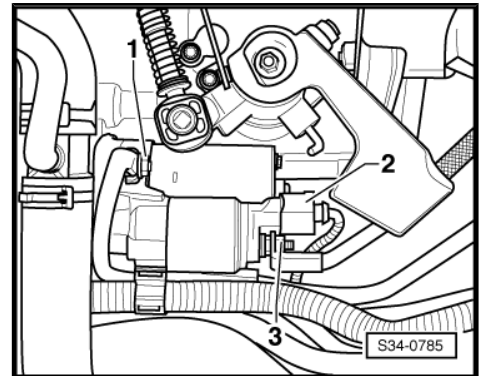

### Tightening torques

Fixing nut for battery positive cable to starter (starter with copper screw)	16 Nm
Fixing nut for battery positive cable to starter (starter with steel screw)	20 Nm
Fixing nuts for battery earth strap	20 Nm
Securing nuts of the cable holder	23 Nm
Fixing screws for M12 starter	80 Nm
Fixing screws for M10 starter	40 Nm



## 3 Generator

⇒ [“3.1 Checking generator”, page 14](#)

⇒ [“3.2 Removing and installing alternator”, page 14](#)

⇒ [“3.3 Fixing the B+ wire to the AC generator”, page 19](#)

⇒ [“3.4 Checking the carbon brushes of the AC generator”, page 19](#)

⇒ [“3.5 Removing and installing the Bosch voltage regulator”, page 20](#)

⇒ [“3.6 Removing and installing the Valeo voltage regulator”, page 20](#)

⇒ [“3.7 Removing and installing poly V-belt pulley”, page 21](#)

### 3.1 Checking generator

The AC generator can be inspected with the ⇒ Vehicle diagnostic tester in the function “Targeted fault finding” point – body / electrical system / 27-starter, voltage supply / electrical components / AC generator - C- .

### 3.2 Removing and installing alternator

⇒ [“3.2.1 Removing and installing alternator - vehicles with TDI engines with common rail injection”, page 14](#)

⇒ [“3.2.2 Removing and installing alternator - vehicles with 1.2/1.4 TSI, 1.6 MPI engines”, page 16](#)

⇒ [“3.2.3 Removing and installing alternator - vehicles with 1.8 TSI engine”, page 17](#)

#### 3.2.1 Removing and installing alternator - vehicles with TDI engines with common rail injection

##### Removing

- Disconnect battery earth strap  
⇒ [“1.1 Disconnecting and reconnecting battery”, page 5](#) .
- Remove the poly-V belt ⇒ engine; Rep. gr. 13 .
- Remove engine cover.
- Remove the fuel filter ⇒ Engine; Rep. gr. 20 and lay it to the side (do not detach hoses).
- Remove the sound dampening system ⇒ Body Work; Rep. gr. 50 .
- Remove charge air hose and charge air pipe ⇒ Engine; Rep. gr. 21 .
- Remove fan shroud ⇒ Engine; Rep. gr. 19 .
- Remove AC compressor (do not open the refrigerant circuit) and secure to the side so that the intake hoses are not excessively strained ⇒ Heating, Air Conditioning; Rep. gr. 87 .



- Remove the screen cap from the fixing nut of the B+ cable -1- and unscrew the nut.
- Disconnect plug connection -2-.
- Unscrew the fixing nut for line holder -3- and lay the line to the side.

# ŠKODA

## Vehicles with AC generator attached from front

- Release screws -arrows-.

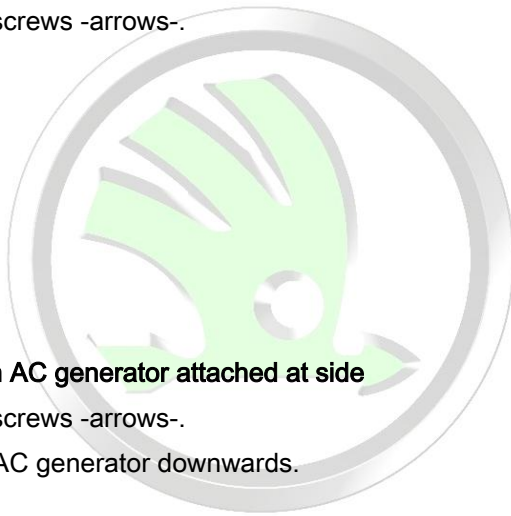

## Vehicles with AC generator attached at side

- Release screws -arrows-.
- Remove AC generator downwards.

### Install

Installation is performed in the reverse order, pay attention to the following points:



### Caution

**Follow the mounting sequence for the poly-V belt → Engine; Rep. gr. 13**

**Fix the B+ wire correctly to the AC generator ⇒ "3.3 Fixing the B+ wire to the AC generator", page 19 .**

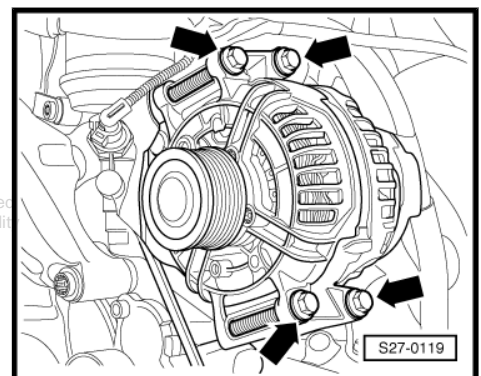
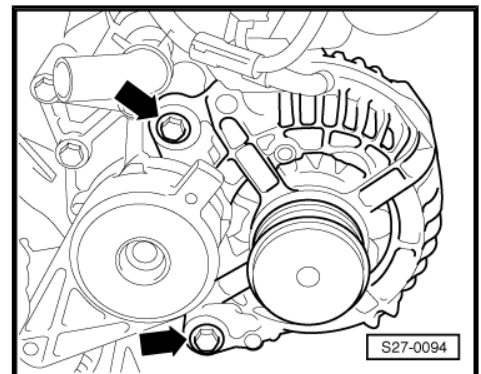
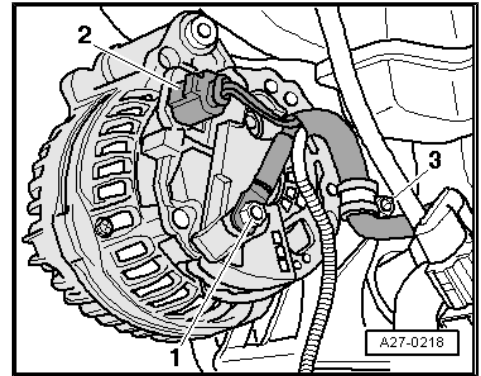

## Vehicles with AC generator attached from front

- For easier mounting move the threaded bushes -A- approx. 3 mm -arrows-.

### Continued for all vehicles

- Observe the tightening torque for fastening the B+ wire see ⇒ "3.3 Fixing the B+ wire to the AC generator", page 19 .
- Pay attention to the work sequence when connecting the battery ⇒ "1.1 Disconnecting and reconnecting battery", page 5 .

### Tightening torques

Fixing screws of AC generator	23 Nm
Fixing nuts for cable on the AC generator	3.2 Nm

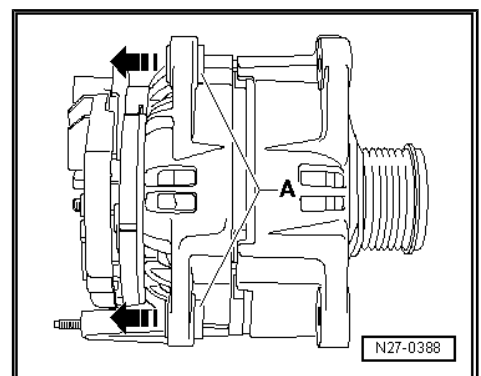

### 3.2.2 Removing and installing alternator - vehicles with 1.2/1.4 TSI, 1.6 MPI engines

#### Removing

- Disconnect battery earth strap  
⇒ [“1.1 Disconnecting and reconnecting battery”, page 5](#) .
- Remove the poly-V belt ⇒ engine; Rep. gr. 13 .
- Remove AC compressor (do not open the refrigerant circuit) and secure to the side so that the intake hoses are not excessively strained ⇒ Heating, Air Conditioning; Rep. gr. 87 .

#### Vehicles with air conditioning and CBZB, CAXA engines

- Remove the cover -1- and unscrew the idler roller -2-.



#### Note

On vehicles without air conditioning, there is no idler roller in front of the alternator.

#### Vehicles with CYVB, CZCA, CZDA, CWVA engines

- Remove V-ribbed belt tensioning device ⇒ Engine; Rep. gr. 13 .

#### Continued for all engines

- Remove the screen cap from the fixing nut of the B+ cable -1- and unscrew the nut.
- Disconnect plug connection -2-.
- Unscrew the fixing nut for line holder -3- and lay the line to the side.

- Release screws -arrows-.

- Remove AC generator downwards.

#### Install

Installation is performed in the reverse order, pay attention to the following points:



#### Caution

Follow the mounting sequence for the poly-V belt ⇒ Engine; Rep. gr. 13

Fix the B+ wire correctly to the AC generator  
⇒ [“3.3 Fixing the B+ wire to the AC generator”, page 19](#) .

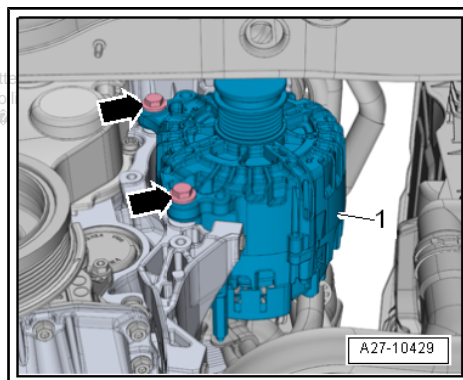
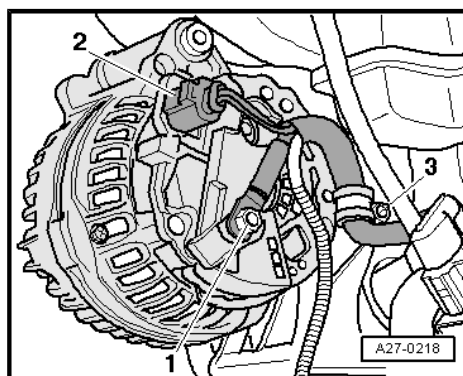
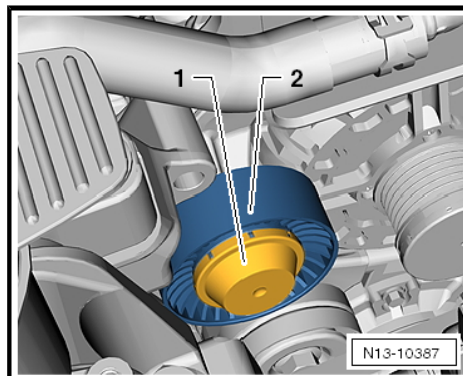



- For easier mounting move the threaded bushes -A- approx. 3 mm -arrows-.
- Observe the tightening torque for fastening the B+ wire see => ["3.3 Fixing the B+ wire to the AC generator", page 19](#) .
- Pay attention to the work sequence when connecting the battery => ["1.1 Disconnecting and reconnecting battery", page 5](#) .

**Tightening torques**

Fixing screws of AC generator	23 Nm
Fixing nuts for cable on the AC generator	3.2 Nm

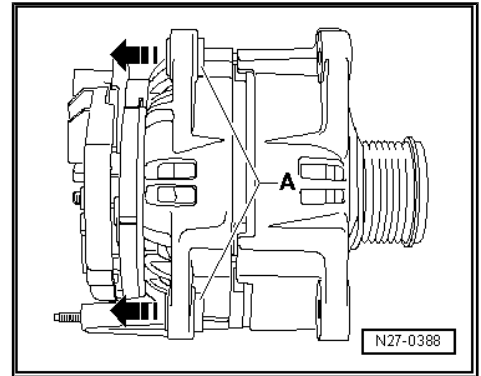

**3.2.3 Removing and installing alternator - vehicles with 1.8 TSI engine**

**Removing**

- Disconnect battery earth strap => ["1.1.1 Disconnect battery", page 5](#) .
- Remove the poly-V belt => engine; Rep. gr. 13 .
- Disconnect plug connection -2-.
- Unscrew -1- oil pressure sender (spanner SW 24).
- Remove four fixing screws -arrows- for alternator.
- Swivel alternator slightly to the left, so that the rear side is accessible.

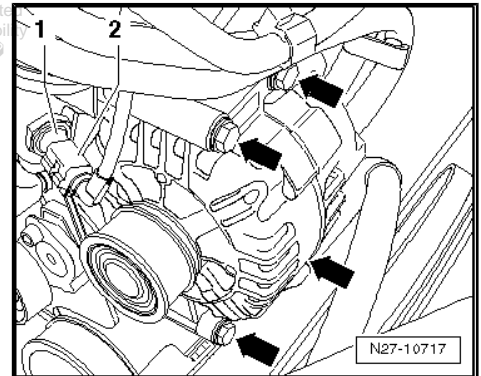

- Disconnect plug connection -1-.

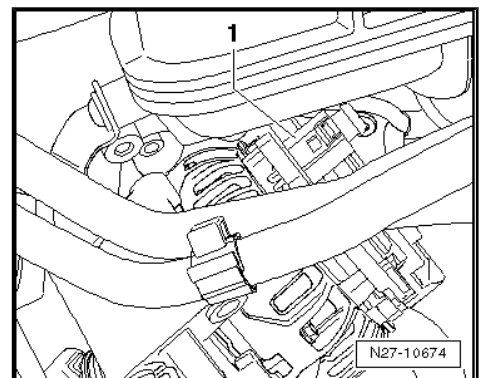

- Remove the screen cap -1- from the fixing nut of the B+ cable.

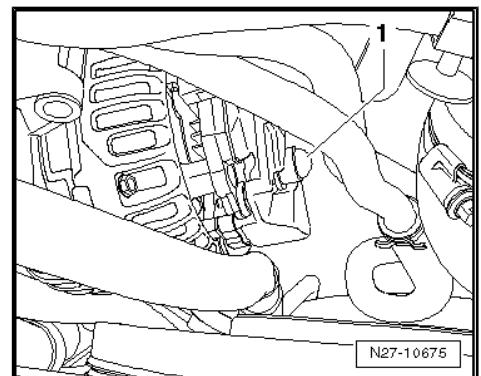



- Unscrew the fixing nut -2- and detach the B+ cable -1- from the alternator.

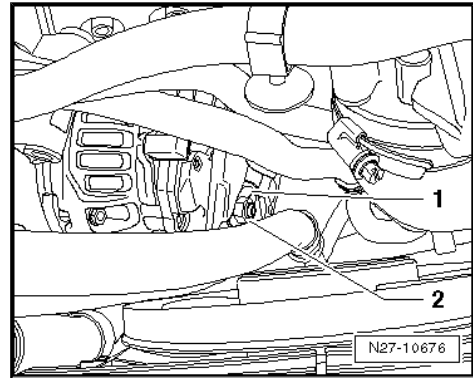

- Unscrew the fixing screws -arrows- and put the pipe and the hose -1- at the top to ensure there is enough space to remove the alternator.



**Note**

*The pipe and hose lines can be left connected.*

- Remove AC generator upwards.

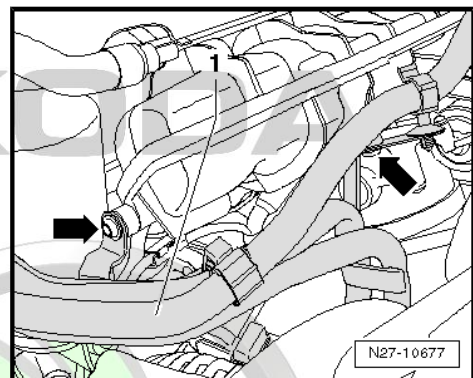

**Install**

Installation is performed in the reverse order, pay attention to the following points:



**Caution**

*Follow the mounting sequence for the V-ribbed belt ⇒ Engine; Rep. gr. 13*

*Fix the B+ wire correctly to the AC generator ⇒ "3.3 Fixing the B+ wire to the AC generator", page 19 .*

- Observe the tightening torque for fastening the B+ wire see ⇒ "3.3 Fixing the B+ wire to the AC generator", page 19 .
- Pay attention to the work sequence when connecting the battery ⇒ "1.1 Disconnecting and reconnecting battery", page 5 .

**Tightening torques**

Fixing screws of AC generator	23 Nm
Fixing nuts for cable on the AC generator	3.2 Nm



### 3.3 Fixing the B+ wire to the AC generator



#### Caution

**Risk of sparks, short-circuit and fire!**

**The screw connection for the B+ cable at the generator is identified with B1+!**

**If the B+ cable is not tightened to the specified tightening torque, this may result in the following risks:**

- ◆ The battery will not charge fully.
- ◆ Complete failure of vehicle electronics
- ◆ Spark formation may cause a fire
- ◆ Damage resulting from overvoltage on electronic components and control units

**The cable to terminal B+ must be laid and attached so that it does not come into contact with rotating or moving parts of the assembly (e.g. with the shift mechanism, with rotating parts of the assembly etc.)!**

**In an incorrect cable/cable attachment to terminal B+ can cause cable damage, a short-circuit and a vehicle fire.**



#### Note

Always use a new self-locking nut for attaching the B+ cable -arrow-, see ⇒ *Electronic Catalogue of Original Parts* .

#### Tightening torques

Self-locking nut of B+ line (-arrow-)	20 Nm
---------------------------------------	-------

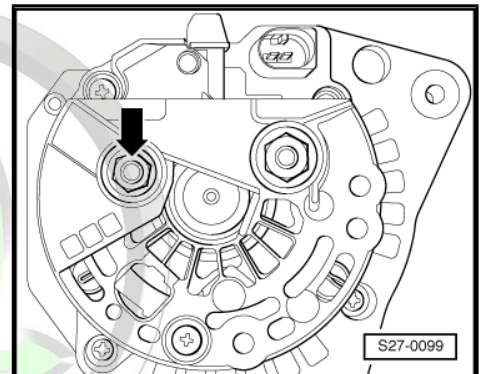

### 3.4 Checking the carbon brushes of the AC generator

Length of carbon brushes when new = 12 mm

Wear limit = 5 mm

Tolerance of carbon brushes to each other = +1 mm

Protected by copyright. Copying for private or commercial purposes in any form, in whole, is not permitted unless authorised by ŠKODA AUTO A. S. ŠKODA AUTO A. S. does not give any guarantee or accept liability with respect to the correctness of information in this document. Copyright © 2011 by ŠKODA AUTO A. S.

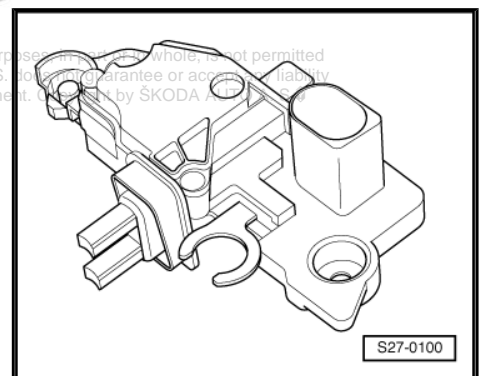



### 3.7 Removing and installing poly V-belt pulley

⇒ [“3.7.1 Removing and installing the poly-V belt pulley on the AC generator without freewheel”, page 21](#)

⇒ [“3.7.2 Removing and installing the poly-V belt pulley with free wheel, manufacturer: Bosch”, page 21](#)

⇒ [“3.7.3 Removing and installing the poly-V belt pulley with free wheel, manufacturer: Valeo”, page 23](#)

⇒ [“3.7.4 Removing and installing the decoupler pulley with free wheel”, page 24](#)

#### 3.7.1 Removing and installing the poly-V belt pulley on the AC generator without free-wheel

Special tools and workshop equipment required

- ◆ Socket insert - T30032 (3310)-
- Remove poly-V belt and/or generator  
 ⇒ [“3.2 Removing and installing alternator”, page 14](#) .
- Remove the poly-V belt pulley using the socket insert - T30032 (3310)- .

Removal - turn the alternator shaft to the right.

Installation - turn the alternator shaft to the left.

Tightening torques

Fixing nuts of V-ribbed belt	65 Nm
------------------------------	-------

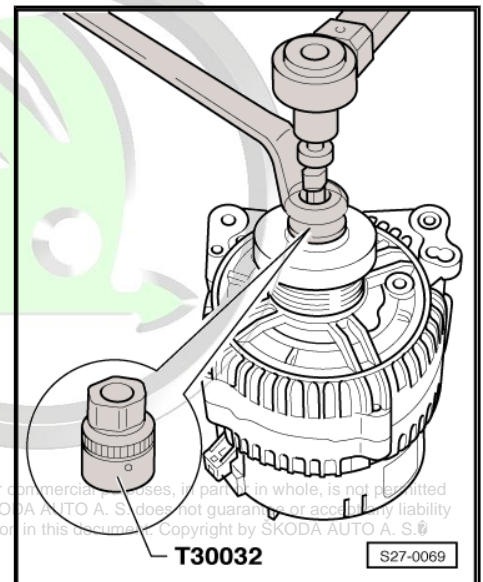

Protected by copyright. Copying for private or commercial purposes, in part or in whole, is not permitted unless authorised by ŠKODA AUTO A. S. ŠKODA AUTO A. S. does not guarantee or accept any liability with respect to the correctness of information in this document. Copyright by ŠKODA AUTO A. S. ©

#### 3.7.2 Removing and installing the poly-V belt pulley with free wheel, manufacturer: Bosch

Special tools and workshop equipment required

- ◆ Multipoint adapter - MP 1-309 (3400)-

Removing

- Remove AC generator - C-  
 ⇒ [“3.2 Removing and installing alternator”, page 14](#) .
- Clamp the AC generator - C- in a vice at the attachment points.
- Lever cap off the poly V-belt pulley.



- Insert polygon-head adapter - MP 1-309 (3400)- with ring spanner (width across flats 17) into the poly V-belt pulley.
- Insert polygon-head socket insert M10 -1- into the alternator shaft.
- Hold alternator shaft and detach poly V-belt pulley with ring spanner by rotating to the left.
- Hold poly V-belt pulley by hand.
- Turn alternator shaft until the poly V-belt pulley can be removed.

**Install**

Installation is performed in the reverse order, while paying attention to the following:

- Screw poly V-belt pulley onto the alternator shaft by hand as far as possible.

The torque wrench - V.A.G 1332- must be modified as follows for assembly of the poly V-belt:

- Release socket drive -1- and pull off grip -2-.
- Turn the handle piece -2- by 180° and fit socket insert -1- again.
- Set turning direction of torque wrench - V.A.G 1332- to anti-clockwise at socket insert.

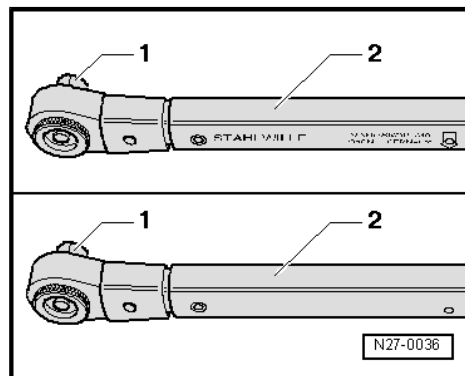
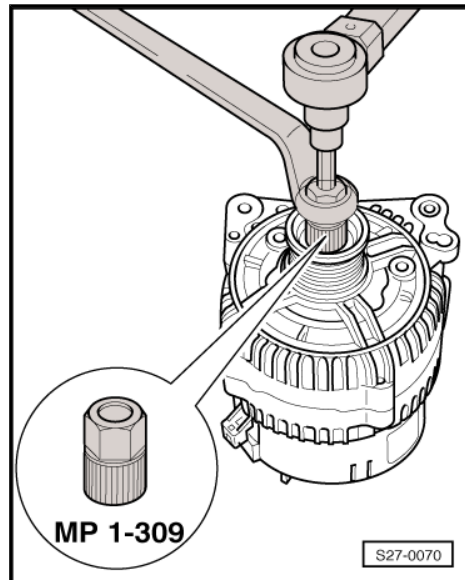

- Insert polygon-head socket insert M10 into the alternator shaft.
- Counterhold polygon-head adapter - MP 1-309 (3400)- with ring spanner (width across flats 17).
- Tighten poly V-belt pulley by rotating the alternator shaft to the left with torque wrench - V.A.G 1332- .

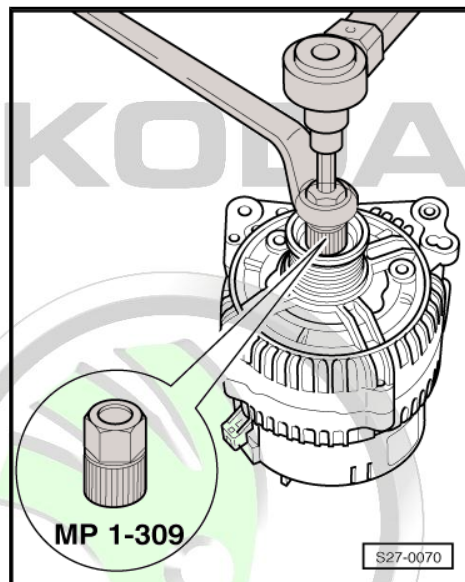

**Tightening torques**

Poly V-belt pulley to alternator shaft	80 Nm
--	-------

### 3.7.3 Removing and installing the poly-V belt pulley with free wheel, manufacturer: Valeo

#### Special tools and workshop equipment required

- ◆ Multipoint adapter - MP 1-309 (3400)-

#### Removing

- Remove AC generator - C-  
 ⇒ "3.2 Removing and installing alternator", page 14 .
- Clamp the AC generator - C- in a vice at the attachment points.
- Lever cap off the poly V-belt pulley.
- Insert polygon-head adapter - MP 1-309 (3400)- with ring spanner (width across flats 17) into the poly V-belt pulley.
- Insert Torx screwdriver socket into the alternator shaft.
- Hold alternator shaft and detach poly V-belt pulley with ring spanner by rotating to the left.
- Hold poly V-belt pulley by hand.
- Turn alternator shaft until the poly V-belt pulley can be removed.

#### Install

Installation is performed in the reverse order, while paying attention to the following:

- Screw poly V-belt pulley onto the alternator shaft by hand as far as possible.

The torque wrench - V.A.G 1332- must be modified as follows for assembly of the poly V-belt:

- Release socket drive -1- and pull off grip -2-.
- Turn the handle piece -2- by 180° and fit socket insert -1- again.
- Set turning direction of torque wrench - V.A.G 1332- to anti-clockwise at socket insert.

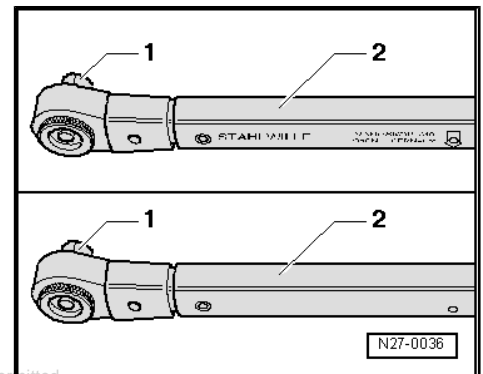
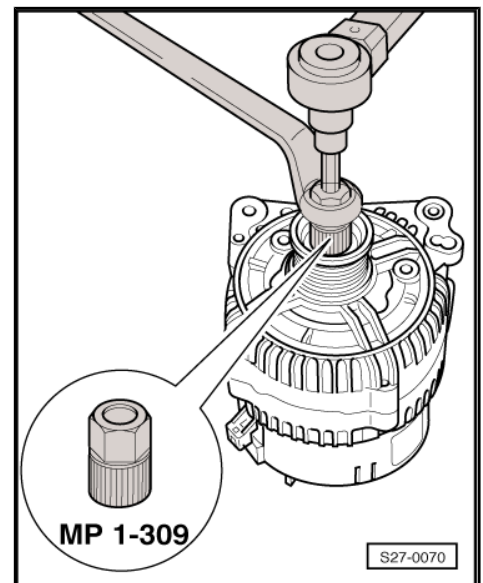

Protected by copyright. Copying for private or commercial purposes, in part or in whole, is not permitted unless authorised by ŠKODA AUTO A. S. ŠKODA AUTO A. S. does not guarantee or accept any liability with respect to the correctness of information in this document. Copyright by ŠKODA AUTO A. S. ©



- Insert Torx screwdriver socket into the alternator shaft.
- Counterhold polygon-head adapter - MP 1-309 (3400)- with ring spanner (width across flats 17).
- Tighten poly V-belt pulley by rotating the alternator shaft to the left with torque wrench - V.A.G 1332- .

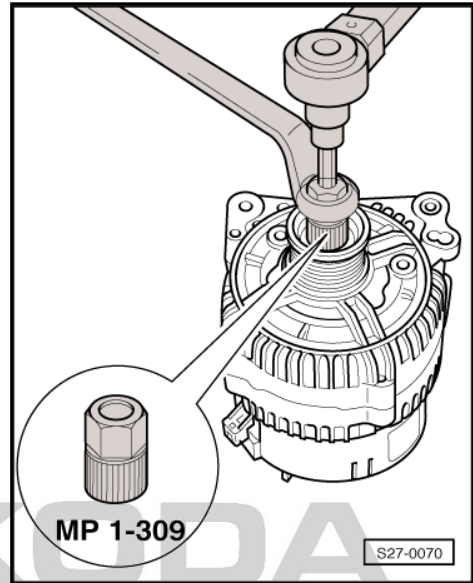

**Tightening torques**

Poly V-belt pulley to alternator shaft	80 Nm
--	-------

**3.7.4 Removing and installing the decoupler pulley with free wheel**

**General description**

Depending on equipment, different decoupler pulleys with free-wheel are installed.

Before removing, you must check which special tool to use to remove the installed decoupler pulley with freewheel.

**Differentiating the decoupler pulleys with free wheel**

-A- Small decoupler pulley with freewheel – as special tool, use the polygon-head adapter - T10474-

-A- Large decoupler pulley with freewheel – as special tool, use the polygon-head adapter - MP 1-309 (3400)-

**Note**

- ◆ *The length of the poly V-belt is different, depending on the installed decoupler pulley with freewheel.*
- ◆ *The diameter of the decoupler pulley with freewheel is different for vehicles with and without air conditioning system.*
- ◆ *Check which decoupler pulley with freewheel is installed and ensure that a poly V-belt of the right length is installed. Correct assignment of the V-ribbed belt ⇒ Electronic Catalogue of Original Parts "ETKA".*

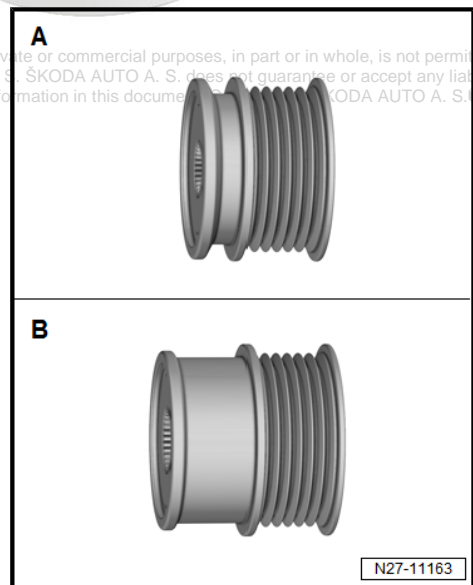

**Special tools and workshop equipment required**

- ◆ Multipoint adapter - T10474-



◆ Multipoint adapter - MP1-309 (3400)-

**Removing**

- Remove AC generator - C-  
 ⇒ "3.2 Removing and installing alternator", page 14 .
- Clamp the AC generator - C- in a vice at the attachment points.
- Remove protective cap (where there is one) from decoupler pulley with freewheel.
- Insert polygon-head adapter - T10474- or polygon-head adapter - MP 1-309 (3400)- Pos. -1- into the poly V-belt pulley and fit a ring spanner.
- Insert a suitable tool -2- into the alternator shaft.
- Turn alternator shaft clockwise to loosen it, counterholding with the ring spanner.
- Hold decoupler pulley with freewheel stationary with your hand and turn alternator shaft until decoupler pulley with freewheel can be removed.

**Install**

Installation is performed in a similar way in the reverse order. Pay attention to the following points:

The torque wrench - V.A.G 1332- must be modified for assembly of the decoupler pulley with freewheel as follows:

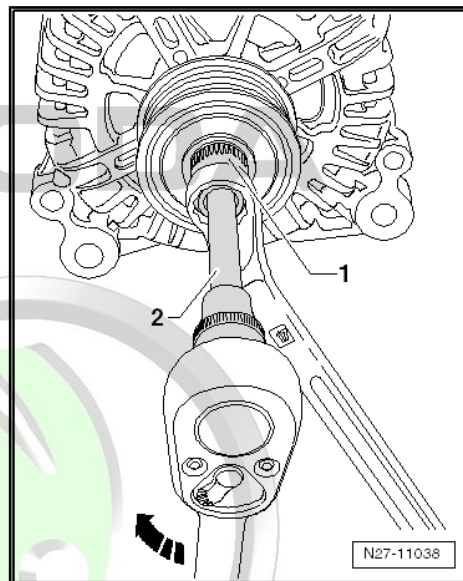

- Release socket drive -1- and pull off grip -2-.
- Turn torque wrench grip -2- 180° and reinsert socket drive.
- Set turning direction of torque wrench to anti-clockwise at socket drive.
- First screw poly V-belt pulley with freewheel onto alternator shaft by hand as far as possible.
- Insert polygon-head adapter - T10474- -1- into the decoupler pulley with freewheel and fit a ring spanner.

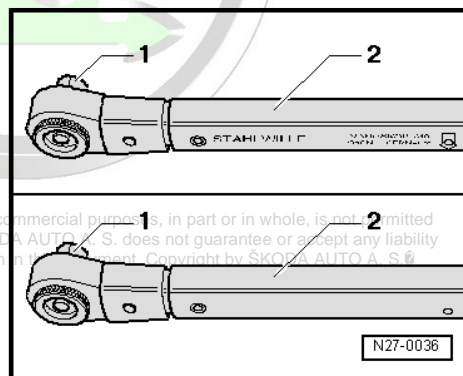

Protected by copyright. Copying for private or commercial purposes, in part or in whole, is not permitted unless authorised by ŠKODA AUTO A. S. ŠKODA AUTO A. S. does not guarantee or accept any liability for information in this manual. Copyright by ŠKODA AUTO A. S.



- Insert a suitable tool -2- into the alternator shaft.
- Turn alternator shaft anti-clockwise using the torque wrench - V.A.G 1332- -3- to tighten the decoupler pulley with freewheel.

**Tightening torques**

Decoupler pulley with free wheel to alternator shaft	80 Nm
--	-------

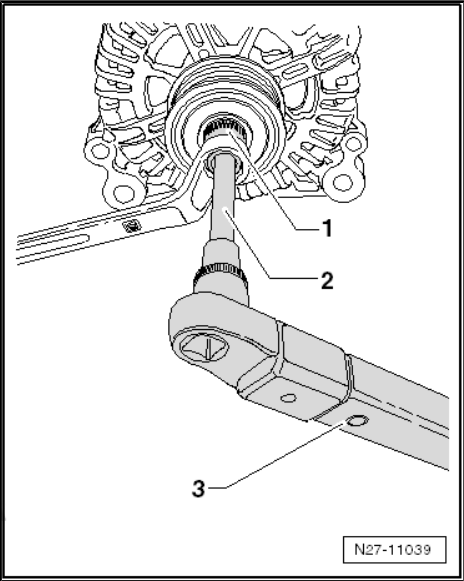

ŠKODA



Protected by copyright. Copying for private or commercial purposes, in part or in whole, is not permitted unless authorised by ŠKODA AUTO A. S. ŠKODA AUTO A. S. does not guarantee or accept any liability with respect to the correctness of information in this document. Copyright by ŠKODA AUTO A. S. ©

## 4 "Start-stop" system

⇒ ["4.1 Safety precautions for vehicles with start-stop system", page 27](#)

⇒ ["4.2 General description", page 27](#)

⇒ ["4.3 Fault recognition and fault display", page 28](#)

⇒ ["4.4 Battery recharging or starting by external source on vehicles with start-stop system", page 28](#)

⇒ ["4.5 Replacing the battery on vehicles with start-stop system", page 28](#)

⇒ ["4.6 Voltage stabilizer J532", page 29](#)

⇒ ["4.7 Battery monitoring control unit J367", page 30](#)

⇒ ["4.8 Button for start-stop system", page 30](#)

### 4.1 Safety precautions for vehicles with "start-stop" system



#### WARNING

*Risk of injury from automatic engine start.*

- ◆ *On vehicles with activated start-stop system (recognizable by a message in the dash panel insert) there is a risk that the engine can start automatically.*
- ◆ *It is therefore necessary to ensure that the start-stop system is deactivated when carrying out work on the vehicle (switch ignition off, if required switch ignition on again).*

### 4.2 General description

The start-stop system is designed to reduce fuel consumption and thus contributes to the reduction of pollutant emissions.

For this purpose the engine automatically switches off during standstill phases of the vehicle and restarts automatically or when operating the clutch pedal.

The system is always automatically activated when the ignition is switched on and can be deactivated with the "start-stop" button in the centre console.

Detailed description of the function as well as conditions for the operation of the start-stop system see:

- ◆ ⇒ Self-study programme No. 86 ; Start-stop system in Škoda vehicles
- ◆ ⇒ Owner's manual Yeti

Connection diagram of the start-stop system ⇒ Current flow diagrams, Electrical fault finding and Fitting locations.

**Note**

- ◆ *The components adapted for the start-stop system are not specifically designated and differ only slightly from the usual components (e.g. starter, generator).*
- ◆ *When carrying out repairs, pay attention to the correct designation of the spare parts see ⇒ *Electronic Catalogue of Original Parts* .*

### 4.3 Fault recognition and fault display

The start-stop system is implemented in the software of the engine control unit - J623- as a function.

The engine control unit is equipped with self-diagnosis, which facilitates the fault finding.

For fault finding use the ⇒ Vehicle diagnostic tester in the function "Targeted fault finding".

### 4.4 Battery recharging or starting by external source on vehicles with "start-stop system"

**When recharging or jump start on vehicles with start/stop system, observe the following:**

Do not disconnect the earth strap of the battery when recharging.

First of all connect to the positive terminals using the charge or jump leads; then connect to the body mass (do not connect to the negative terminal of the battery).

**Note**

- ◆ *The direct charging (starting aid) of the battery at the negative terminal results in the bypass of the battery monitoring control unit - J367- (then the current flow is not monitored by this control unit).*
- ◆ *The values regarding the battery state, which are stored in the data bus diagnostic interface - J 533- (Gateway), would then no longer correspond to the values of the charged battery.*
- ◆ *This can lead to the failure of the start-stop system.*
- ◆ *Test and charging procedure for the battery "Electrical System - General notes" ⇒ *Electrical System - General notes; Rep. gr. 27* .*

### 4.5 Replacing the battery on vehicles with "start-stop" system

Instead of the usual lead-acid batteries, a fleece battery (Absorbed Glass Mat) or a battery with magic eye with EFB technology (Enhanced Flooded Battery) must be used as a starter battery because of its higher cycle durability during cold start (depending on types of engines see ⇒ *Electronic Catalogue of Original Parts* ).

When replacing the battery, only install a fleece battery again or a battery with EFB technology with the same capacity (see ⇒ *Electronic catalogue of original parts* ).

When replacing the battery with a new one, another type of battery or a battery of a higher capacity you must set the battery parameters, see ⇒ ["1.7 Battery parameterisation", page 10](#) .

 **Note**

*Description of the function, test and maintenance of the previous batteries see "Electrical System – General notes" ⇒ Electrical System – General notes; Rep. gr. 27 .*

## 4.6 Voltage stabilizer - J532-

Its task is to stabilise the high voltage drop of the on-board power supply, resulting from the start-stop operation, to 12 volts.

If it becomes apparent that the electrical consumers (such as radio/navigation, telephone, dash panel insert) must be reset at each engine start, while operating the start-stop system, this indicates that the voltage stabilizer is defective.

If the above mentioned electrical consumers fail at the same time, first of all check the fuse of the voltage stabilizer see ⇒ Current flow diagrams, Electrical fault finding and Fitting locations.

A direct entry relating to a malfunction of the voltage stabilizer via ⇒ Vehicle diagnostic tester is not made at present.

The voltage stabiliser - J532- is located in the following positions:

- ◆ Vehicles without SoundSystem equipment – under the left front seat
- ◆ Vehicles with SoundSystem equipment – under the right front seat

### Removing

- Switch off the ignition and all electrical components.
- Push the left front seat or, in vehicles with SoundSystem equipment, the right front seat, as far backward as possible and to the highest point.
- Lightly raise the edges of the cover in the direction of arrow -A- and remove cover in direction of arrow -B-.

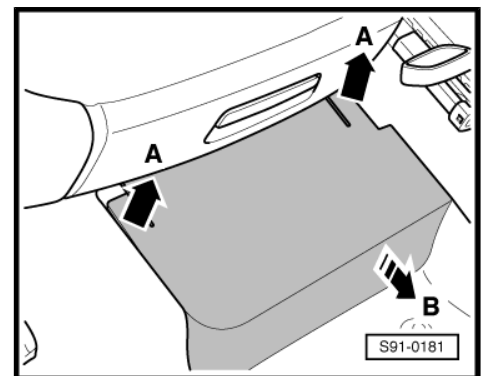



- Unscrew the fixing screws -arrows-.
- Disconnect plug and remove the unit.

### Install

Installation is carried out in the reverse order.

### Tightening torques

Fixing screws of the anti-roll bar	3 Nm
------------------------------------	------

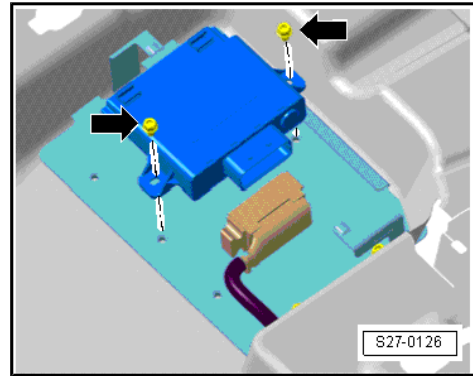

## 4.7 Battery monitoring control unit - J367-

The control unit is located directly at the negative connection terminal of the battery earth strap.

It transmits information on whether the battery has enough electric power for the operation of the start-stop system.

It is connected to the data bus diagnostic interface - J533- (Gateway) via the LIN data bus.

In the event of a failure, an entry is made in the event memory. The start-stop system is switched off.



### Note

After replacing, adapt (code) the new battery monitoring control unit - J367- with ⇒ Vehicle diagnostic tester.

# ŠKODA

## 4.8 Button for “start-stop” system

Removing and installing the button for the start-stop system  
 ⇒ [“2.3 Removing and installing switches in centre console”, page 191](#).



Protected by copyright. Copying for private or commercial purposes, in part or in whole, is not permitted unless authorised by ŠKODA AUTO A. S. ŠKODA AUTO A. S. does not guarantee or accept any liability with respect to the correctness of information in this document. Copyright by ŠKODA AUTO A. S.



## 90 – Gauges, instruments

### 1 Dash panel insert

⇒ [“1.1 General description”, page 31](#)

⇒ [“1.2 Adjust/replace dash panel insert”, page 32](#)

⇒ [“1.3 Removing and installing the dash panel insert”, page 32](#)

⇒ [“1.4 Warning lights in the dash panel insert”, page 33](#)

⇒ [“1.5 Service interval display”, page 34](#)

⇒ [“1.6 The self-diagnostic function of the dash panel insert”, page 34](#)

#### 1.1 General description



##### Note

*When handling a fault it is absolutely essential to know the functions, the setting and the operation of the dash panel insert ⇒ Owner's manual Yeti .*

The dash panel insert is available in two versions:

##### Low line

- ◆ Analogue indicators
- ◆ Display - segmental (white, 240 segments, ABN technology)
- ◆ Warning lights

##### High line

Difference regarding the low line version:

- ◆ Display - dot display (white, 166 x 110 points, TFT technology)
- ◆ The warning lights are identical to the low line version, however some are replaced with the pictogram and/or text display in the Maxidot display
- Oil pressure
- Oil level
- Brake pads
- Door open
- Opening the tailgate

Detailed description of the function of the dash panel insert, the setting and the operation:

- ◆ ⇒ Owner's manual Yeti
- ◆ ⇒ Self-study programme No. 72 ; Škoda Yeti, introduction of the vehicle

Contact assignment of plug connection on the dash panel insert  
⇒ Current flow diagrams, Electrical fault finding and Fitting locations.

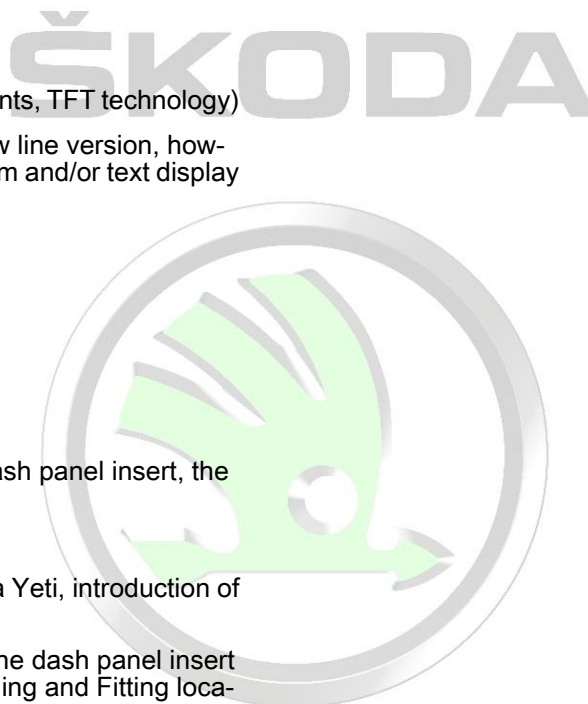



## 1.2 Adjust/replace dash panel insert



### Note

Before replacing the dash panel insert the code of the radio system/navigation, which must be newly adjusted after replacing the dash panel insert, must be determined see ⇒ ["1.2 Electronic anti-theft coding", page 37](#).

⇒ Vehicle diagnostic tester connect on-line (network connection).

If the dash panel insert is replaced, the ⇒ Vehicle diagnostic tester must be connected before the removal of the original dash panel insert and must be confirmed in the guided functions "replace dash panel insert". Thereby the required values must be read into the diagnostic unit from the original dash panel insert. If the original dash panel insert is not available or does not communicate with the diagnostic unit, then proceed according to the information in the ⇒ Vehicle diagnostic tester

After fitting the new dash panel insert, adapt all ignition keys and set the language for the applicable country.

## 1.3 Removing and installing the dash panel insert

Protected by copyright. Copying for private or commercial purposes, in part or in whole, is not permitted unless authorised by ŠKODA AUTO A. S. ŠKODA AUTO A. S. does not guarantee or accept any liability with respect to the correctness of information in this document. Copyright by ŠKODA AUTO A. S. ©



### Note

- ◆ After reading in the information stored in the control unit, the work sequence "adjust/replace dash panel insert" must be carried out before replacing the dash panel insert ⇒ ["1.2 Adjust/replace dash panel insert", page 32](#).
- ◆ The dash panel insert must not be disassembled. In the event of a fault, the dash panel insert must be replaced completely.

### Removing

- Switch off all electrical components and take out the ignition key.
- Pull out the steering wheel -1- towards you and lock it in its lowest position.
- Release the cover -2- and remove it towards you.
- Release screws -arrows-.
- Release the dash panel insert -3- by pulling the round indicators towards you and remove.

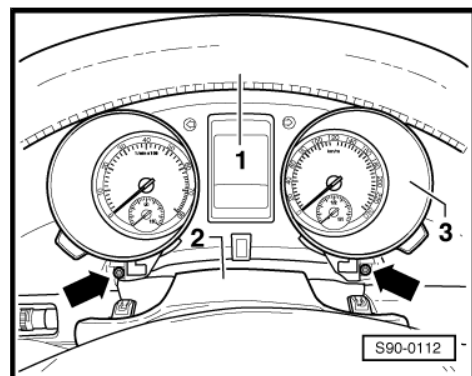

- Press the catch -1- and disconnect the plug connection by tilting out the clamp -arrow-.
- Take out the dash panel insert.

**Install**

Installation is carried out in the reverse order.

**Tightening torques**

Fixing screws for dash panel insert	1.5 Nm
-------------------------------------	--------

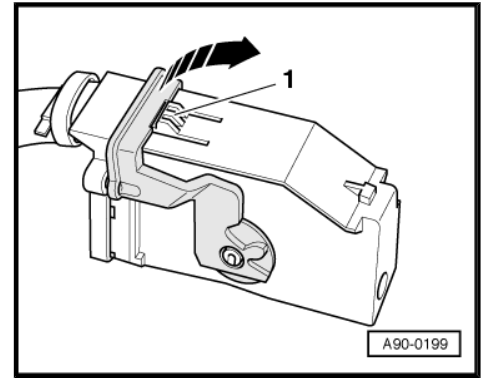

**1.4 Warning lights in the dash panel insert**

 **Note**

- ◆ Detailed description of the function of warning lights => Owner's manual Yeti.
- ◆ The arrangement and number of active warning lights depends on the equipment level and type of dash panel insert.

**1 - Glow Plug System**

- Diesel

**2 - Engine electronics monitor**

- Petrol

**3 - Diesel particle filter**

- Diesel

**4 - Generator**

**5 - Engine oil**

**6 - Low beam**

- inactive on vehicles as of CW 22.2013

**7 - Handbrake**

**8 - Rear fog light**

**9 - Light failure**

**10 - Turn signal**

**11 - Turn signal**

**12 - Put on seat belt**

**13 - Antilock braking system (ABS)**

**14 - Tailgate**

**15 - test:**

- Traction (ASR)
- Stability (ESC)

**16 - Brake system**

**17 - Brake lining thickness**

- not activated

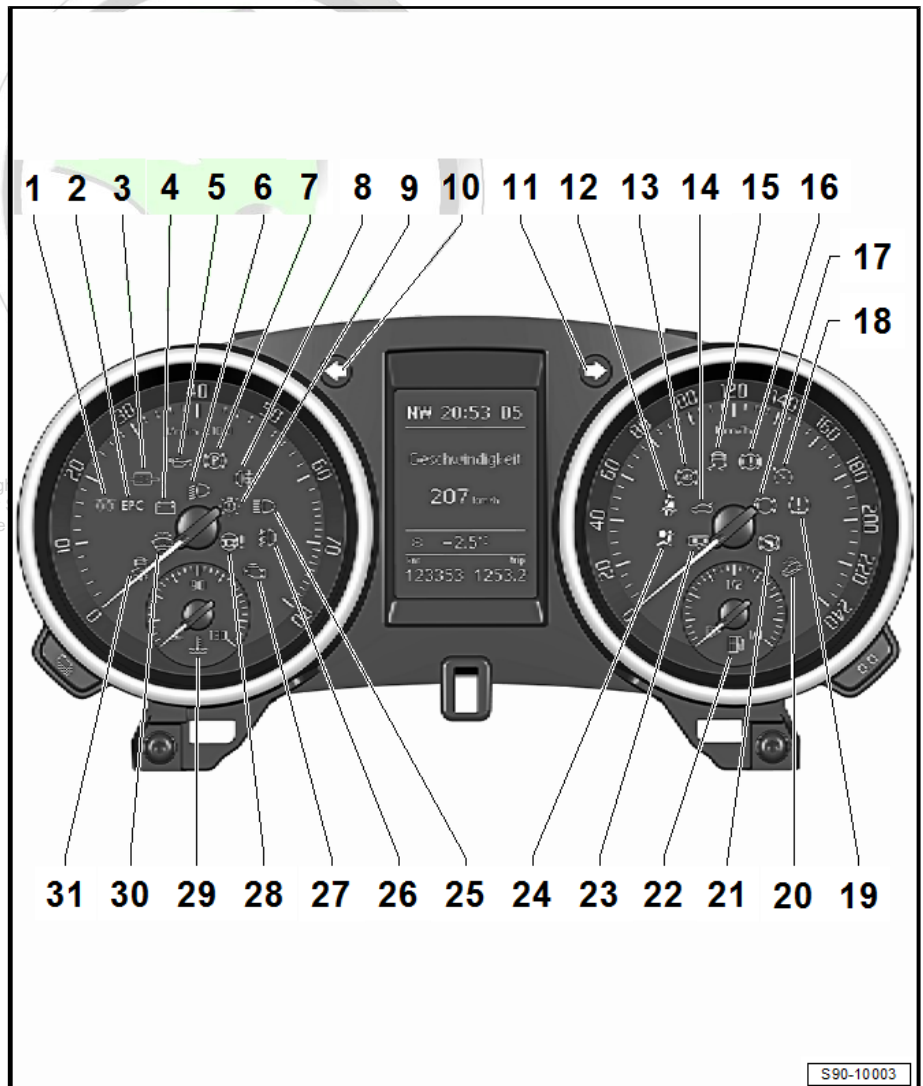



- 18 - Cruise control system
- 19 - Tyre pressure
- 20 - OFF ROAD mode
- 21 - Selector lever lock
- 22 - Fuel reserve
- 23 - Open door
- 24 - Airbag system
- 25 - Main beam
- 26 - Fog lights
- 27 - Exhaust gas control system
- 28 - Power-assisted steering
- 29 - Coolant temperature, coolant amount
- 30 - Washer fluid level
- 31 - Switch off control for traction (ASR)



#### Note

- ◆ *The dash panel insert must not be disassembled.*
- ◆ *All warning lights are designed as LEDs. The dash panel insert must be replaced if a warning/indicator light breaks down.*
- ◆ *The assignment of the warning lights depends upon the vehicle equipment, the country and the engine versions.*

## 1.5 Service interval display

### Operation

The electronic control of the service interval display consists of

- ◆ a time counter
- ◆ two distance counters

The electronic control analyses the contents of the counters so that the customer is informed either

- ◆ after a defined period of time has elapsed

or

- ◆ after a defined distance has been reached

by the service interval display that a service is required (depending on what occurs first).

Reset service interval display ⇒ Maintenance ; Booklet Yeti .

## 1.6 The self-diagnostic function of the dash panel insert

### Initiating self-diagnosis of the dash panel insert

The dash panel insert is controlled by a microprocessor and features a comprehensive self-diagnosis. If faults occur in the system components, fault codes are stored in the event memory of the dash panel insert.



Carry out "self-diagnosis" with the ⇒ Vehicle diagnostic tester in the function "Targeted fault finding".



Protected by copyright. Copying for private or commercial purposes, in part or in whole, is not permitted unless authorised by ŠKODA AUTO A. S. ŠKODA AUTO A. S. does not guarantee or accept any liability with respect to the correctness of information in this document. Copyright by ŠKODA AUTO A. S.®



## 2 Cruise control system (CCS)

The engine control unit controls the function of the CCS on vehicles which have a cruise control.

Apart from the CCS control switch in the left steering-column switch there are no additional components of the CCS.

### Fault recognition and fault display

Faults from the Cruise control system are transmitted via the engine control unit.

For fault finding use:

- ◆ ⇒ Vehicle diagnostic tester in the function "Targeted fault finding".
- ◆ ⇒ Current flow diagrams, Electrical fault finding and Fitting locations.

# ŠKODA



Protected by copyright. Copying for private or commercial purposes, in part or in whole, is not permitted unless authorised by ŠKODA AUTO A. S. ŠKODA AUTO A. S. does not guarantee or accept any liability with respect to the correctness of information in this document. Copyright by ŠKODA AUTO A. S. ©



## 91 – Radio, telephone, navigation

### 1 Radio

- ⇒ [“1.1 General Instructions”, page 37](#)
- ⇒ [“1.2 Electronic anti-theft coding”, page 37](#)
- ⇒ [“1.3 Overview of radio system”, page 38](#)
- ⇒ [“1.4 Removing and installing a radio”, page 40](#)
- ⇒ [“1.5 Self-diagnostic function of radio system”, page 42](#)

#### 1.1 General Instructions



##### Note

- ◆ *When retrofitting equipment, carrying out repair work or fault finding ⇒ Current flow diagrams, Electrical fault finding and Fitting locations, ⇒ installation instructions for the radio and ⇒ Vehicle diagnostic tester in the function “targeted fault finding”.*
- ◆ *Detailed assembly information, e.g. detaching and attaching trim panels ⇒ Body Work; Rep. gr. 70 .*

Other information:

- ◆ ⇒ Operating instruction of the radio
- ◆ ⇒ Self-study programme No. 72 ; Škoda Yeti, introduction of the vehicle

#### 1.2 Electronic anti-theft coding

- ⇒ [“1.2.1 Electronic anti-theft coding for Blues, Swing \(up to 21.2015\) and Bolero \(up to CW 44.2014\) radios”, page 37](#)
- ⇒ [“1.2.2 Electronic anti-theft coding for the Swing \(as of CW 22.2015\) and Bolero \(as of CW 45.2014\) infotainment unit”, page 38](#)

##### 1.2.1 Electronic anti-theft coding for Blues, Swing (up to 21.2015) and Bolero (up to CW 44.2014) radios

The radio system is equipped with Convenience electronic anti-theft lock, which operates in combination with the dash panel insert.

The radio systems are protected with an anti-theft code.

For radio systems mounted at the factory the safety code is only entered in the respective vehicle when it is initial setup. The safety code does no longer have to be re-entered when subsequently disconnecting and re-connecting the battery or when removing and re-installing the radio system in the same vehicle. If the radio system is installed in another vehicle or the dash panel insert is replaced, the safety code must be entered again.

The radio systems in the vehicles are locked at the factory before delivery to the dealers.

Before the vehicle is handed over to the customer, the anti-theft code of the radio must be deactivated by entering a safety code.



The safety code can be read via the online connection with ⇒ Vehicle diagnostic tester (network connection).

The user must have valid authorisation for the use of a programme to determine the radio coding.

Additional information ⇒ Operating Instruction of the radio .



#### Note

- ◆ *If an incorrect safety code is entered, it can be corrected immediately at the next attempt. If an incorrect safety code is entered once again, the radio is blocked for 1 hour.*
- ◆ *After one hour has elapsed, during which the radio as well as the ignition must remain switched on (the time which has elapsed since the lock was activated is shown in the display of the radio), the procedure for deactivating the electronic anti-theft coding can be repeated (always two attempts, then locked for one hour).*

### 1.2.2 Electronic anti-theft coding for the Swing (as of CW 22.2015) and Bolero (as of CW 45.2014) infotainment unit

The Swing/Bolero infotainment unit (hereafter, the Infotainment unit) is equipped with electronic comfort anti-theft coding, which operates in combination with the dash panel insert.

The Infotainment unit must be paired with an appropriate vehicle using the ⇒ Vehicle diagnostic tester. The security code is no longer entered.

The Infotainment unit, which is assembled at the factory, is paired only when it is used for the first time with the corresponding vehicle. If the battery is disconnected and then reconnected or if the Infotainment unit is removed from a vehicle and then re-installed in the same vehicle, pairing with the corresponding vehicle is no longer valid.

If the dash panel insert is replaced, the Infotainment unit must be paired with the relevant vehicle once again.

The user must have valid authorisation to use a programme to pair the Infotainment unit.

Additional information ⇒ Swing/Bolero Infotainment operating manual .

### 1.3 Overview of radio system

The number and the design of the components depend on the vehicle equipment.



Protected by copyright. Copying for private or commercial purposes, in part or in whole, is not permitted unless authorised by ŠKODA AUTO A. S. ŠKODA AUTO A. S. does not guarantee or accept any liability with respect to the correctness of information in this document. Copyright by ŠKODA AUTO A. S. ©

### 1 - Front bass speaker

- Removing and installing  
⇒ [“7.1 Removing and installing the front and rear bass speaker”](#), page 68

### 2 - Front treble speaker

- in the front door trim panel
- Removing and installing  
⇒ [“7.4 Removing and installing the front and rear treble speaker”](#), page 69

### 3 - Multi-functional steering wheel

- Description and body work  
⇒ [“5 Multi-functional steering wheel”](#), page 59

### 4 - Radio

- installed in the dash panel
- Removing and installing  
⇒ [“1.4 Removing and installing a radio”](#), page 40

### 5 - Multimedia socket MEDIA-IN / AUX, USB

- with control unit for multimedia system - J650- (no longer in use as of CW 45.2014)
- in the centre console under the heating/air conditioning control
- Removing and installing multimedia socket  
⇒ [“10 Multimedia socket MEDIA-IN \(MDI\) with control unit for multimedia system J650”](#), page 73
- Removing and installing connection for external audio sources and USB connection  
⇒ [“9 Connection for external audio sources R199”](#), page 71

### 6 - Connection for external audio sources

- in the centre console in the storage compartment under the armrest of the driver
- Removing and installing ⇒ [“9 Connection for external audio sources R199”](#), page 71

### 7 - Rear treble speaker

- in the rear door trim panel
- Removing and installing ⇒ [“7.4 Removing and installing the front and rear treble speaker”](#), page 69

### 8 - Rear bass speaker

- Removing and installing ⇒ [“7.1 Removing and installing the front and rear bass speaker”](#), page 68

### 9 - CD changer

- is located in the left luggage compartment
- Removing and installing ⇒ [“8 CD changer”](#), page 70
- Contact assignment on the CD changer ⇒ [“8.2 Plug connection on the CD changer”](#), page 70

### 10 - Rear window aerial

- Removing and installing ⇒ [“4 Aerial systems”](#), page 54

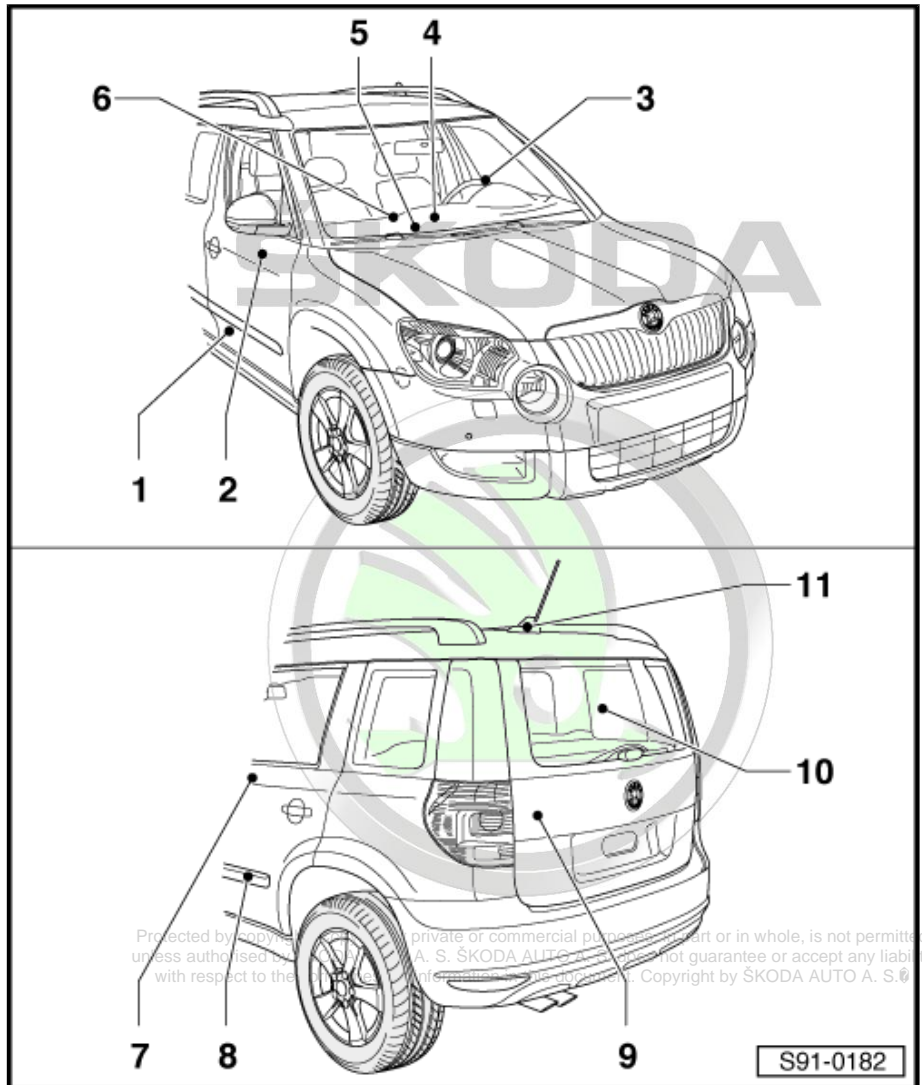

Protected by copyright. Any reproduction, private or commercial purposes, in part or in whole, is not permitted unless authorised by SKODA AUTO A. S. SKODA AUTO A. S. does not guarantee or accept any liability with respect to the information contained in this document. Copyright by SKODA AUTO A. S. ©

S91-0182



## 11 - Roof aerial

- Removing and installing ⇒ [“4 Aerial systems”, page 54](#)

## 1.4 Removing and installing a radio

⇒ [“1.4.1 Radio Blues”, page 40](#)

⇒ [“1.4.2 Radio Swing, Bolero”, page 41](#)

### 1.4.1 Radio “Blues”

#### Removing

- Switch off radio, the ignition and all electrical components.
- Release radio cover frame and heating control using disassembly wedge - 3409- .
- Unclip the caps -1-.
- Unscrew screws -2-.
- Pull the radio out of the dash panel.

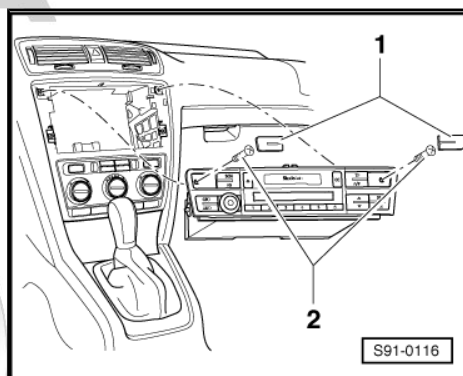

- Compress plug catch -arrows-.

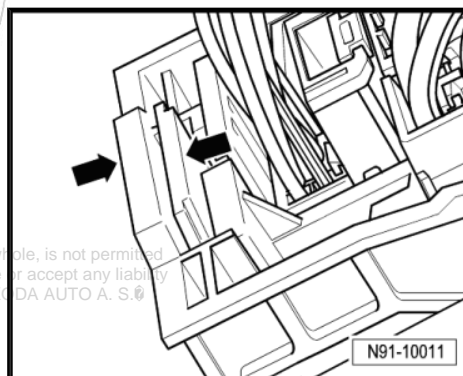

Protected by copyright. Copying for private or commercial purposes, in part or in whole, is not permitted unless authorised by ŠKODA AUTO A. S. ŠKODA AUTO A. S. does not guarantee or accept any liability with respect to the correctness of information in this document. Copyright by ŠKODA AUTO A. S. ©

- Open catch clamp -arrow- and disconnect plug.

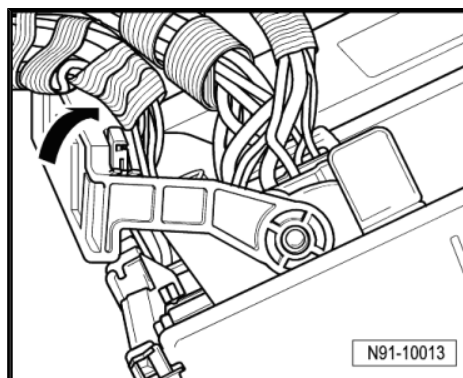



- Release plug of antenna socket -arrow- and disconnect.

### Install

Installation is performed in the reverse order, pay attention to the following points:

#### Note

*When pushing the radio in, do not in any circumstances press on the display or operating buttons. The radio may be damaged.*

If the radio has been replaced:

- Adapt radio by entering the safety code  
 => ["1.2 Electronic anti-theft coding", page 37](#) and code => Vehicle diagnostic tester.

### Tightening torques

Fixing screws for radio	1.5 Nm
-------------------------	--------

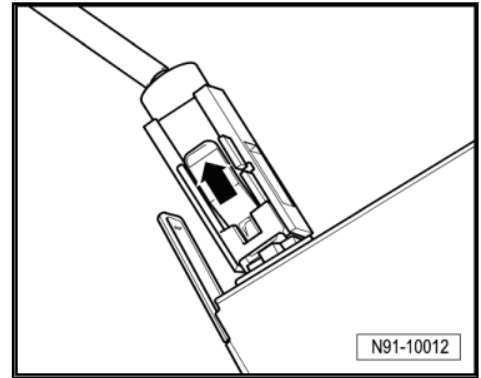

## 1.4.2 Radio "Swing", "Bolero"

### Removing

- Remove all data media/audio media (SD card, CD) from the radio => Radio operating instructions .

#### Note

*The Bolero radio has a 6 disc CD changer (up to CW 44.2014). After removing the last CD, the CD drive is automatically switched off to protect it against damage due to possible vibrations outside the vehicle cockpit.*

- Switch off radio, the ignition and all electrical components.
- Release radio cover frame and heating/air conditioning system control using disassembly wedge - 3409- .
- Then carefully slacken the upper cover of the radio -3-.
- Unscrew the fixing screws -2- and pull the -1- radio out of the dash panel.

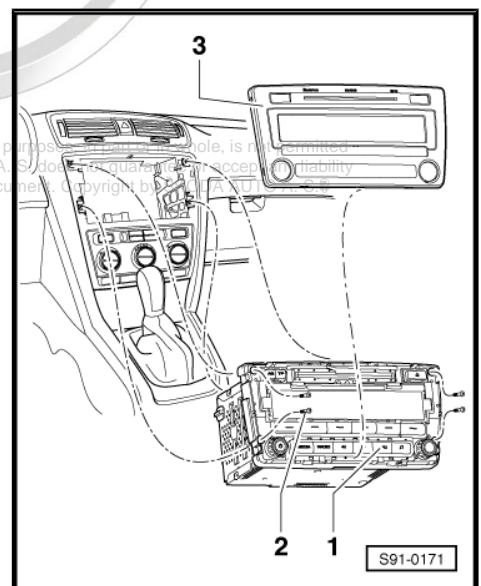

Protected by copyright. Copying for private or commercial purposes, in whole or in part, is not permitted unless authorised by ŠKODA AUTO A. S. ŠKODA AUTO A. S. does not guarantee the acceptability with respect to the correctness of information in this document. Copyright by ŠKODA AUTO A. S.



- Compress plug catch -arrows-.

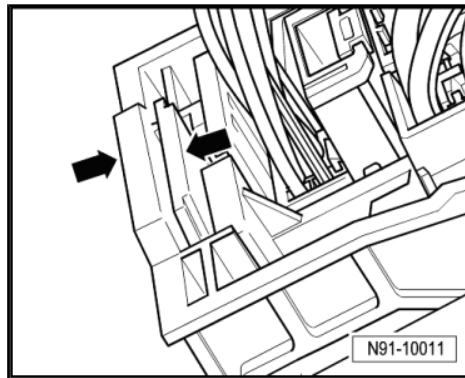

- Open catch clamp -arrow- and disconnect plug.

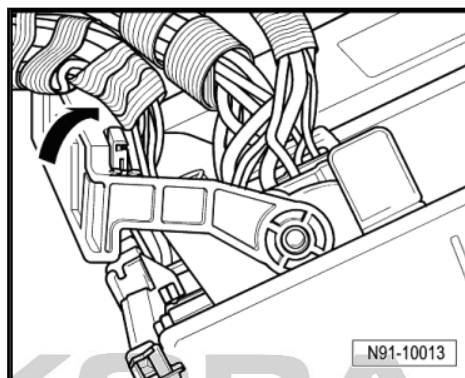

- Release plug of antenna socket -arrows- and disconnect.

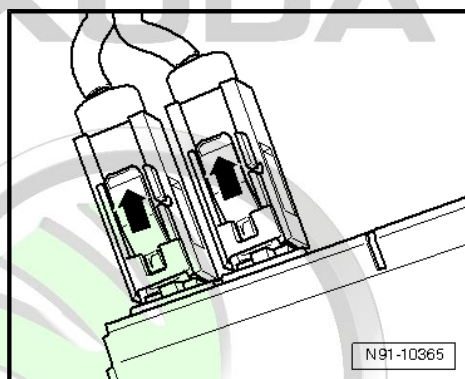

**Install**

Installation is performed in the reverse order, pay attention to the following points:



**Note**

*When pushing the radio in, do not in any circumstances press on the display or operating buttons. The radio may be damaged.*

If the radio has been replaced:

- Adapt ⇒ [“1.2 Electronic anti-theft coding”, page 37](#) and code ⇒ Vehicle diagnostic tester the radio.

**Tightening torques**

Fixing screws for radio	1.5 Nm
-------------------------	--------

**1.5 Self-diagnostic function of radio system**

Carry out “self-diagnosis” with the ⇒ Vehicle diagnostic tester in the function “Targeted fault finding”.

Copying for private or commercial purposes, in part or in whole, is not permitted unless authorised by ŠKODA AUTO A. S. ŠKODA AUTO A. S. does not guarantee or accept any liability with respect to the correctness of information in this document. Copyright by ŠKODA AUTO A. S. ©

## 2 Navigation system Amundsen and Columbus

⇒ [“2.1 General description”, page 43](#)

⇒ [“2.2 General Instructions”, page 44](#)

⇒ [“2.3 Electronic anti-theft coding”, page 44](#)

⇒ [“2.4 Overall view of the navigation system”, page 45](#)

⇒ [“2.5 Removing and installing the navigation system”, page 47](#)

⇒ [“2.6 Self-diagnosis of the navigation system”, page 48](#)

### 2.1 General description

As of CW 45.2014, only the Amundsen system is installed.

The double DIN housing of the system contains

- ◆ an RDS radio
- ◆ Control unit for traffic information for the reception of traffic information
- ◆ Colour display
- ◆ a navigation system with GPS satellite receiver
- ◆ As of CW 22.2011, a Bluetooth module is integrated in the Amundsen+ navigation system, which fulfils the function of the GSM II mobile phone pre-installation (the control unit for the mobile phone operating electronics - J412- that is located under the right seat is no longer fitted). The control unit for the mobile phone operating electronics - J412- is still under the right seat for the GSM III mobile phone pre-installation for vehicles up to CW 44.2014. After this date, the control unit for the mobile phone operating electronics - J412- is no longer installed and the mobile phone pre-installation is integrated into the navigation system.
- ◆ Up to CW 44.2014 - CD (Amundsen)/ DVD (Columbus) drive for navigation system, can play CDs/DVDs
- ◆ as of CW 45.2014 - 2x SD card slots

Other information:

- ◆ ⇒ Operating instruction of the navigation system
- ◆ ⇒ Self-study programme No. 72 ; Škoda Yeti, introduction of the vehicle
- ◆ ⇒ Self-study programme No. 61 ; Radio navigation system in Skoda vehicles



## 2.2 General Instructions



### Note

- ◆ *When handling a fault it is absolutely essential to know the functions and the operation of the navigation system.*
- ◆ *When retrofitting equipment, carrying out repair work or fault finding ⇒ Current flow diagrams, Electrical fault finding and Fitting locations, use ⇒ installation instructions for the navigation system and ⇒ Vehicle diagnostic tester in the function "targeted fault finding".*
- ◆ *Detailed assembly information, e.g. detaching and attaching trim panels ⇒ Body Work; Rep. gr. 70 .*
- ◆ *Additional information ⇒ Operating instruction of the navigation system .*

# ŠKODA

## 2.3 Electronic anti-theft coding

⇒ ["2.3.1 Electronic anti-theft coding - radio navigation system up to CW 44.2014", page 44](#)

⇒ ["2.3.2 Electronic anti-theft coding - Amundsen infotainment unit as of CW 45.2014", page 45](#)

### 2.3.1 Electronic anti-theft coding - radio navigation system up to CW 44.2014

The navigation system is equipped with Convenience electronic anti-theft lock, which operates in combination with the dash panel insert.

The navigation systems are protected against theft with a safety code.

For navigation systems mounted at the factory, the safety code is only entered in the respective vehicle when it is first put into service. The safety code does no longer have to be re-entered when subsequently disconnecting and re-connecting the battery or when removing and re-installing the unit in the same vehicle. If the navigation system is installed in another vehicle or the dash panel insert is replaced, the safety code must be entered again.

The navigation systems in the vehicles are locked at the factory before delivery to the dealers.

Before the vehicle is handed over to the customer, the anti-theft code of the navigation system must be deactivated by entering a safety code.

The safety code can be read via the online connection with ⇒ Vehicle diagnostic tester (network connection).

The user must have a valid authorisation for the use of a programme to determine the coding of the navigation system.

Additional information ⇒ Operating instruction of the navigation system .

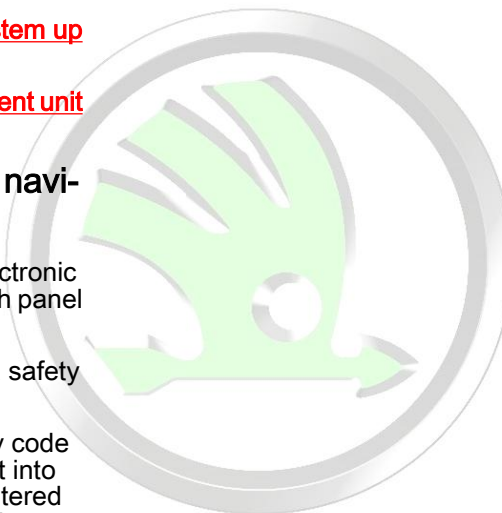

Copying for private or commercial purposes, in part or in whole, is not permitted. ŠKODA AUTO A. S. ŠKODA AUTO A. S. does not guarantee or accept any liability for the correctness of information in this document. Copyright by ŠKODA AUTO A. S.



#### Note

- ◆ *If an incorrect safety code is entered, it can be corrected immediately at the next attempt. If an incorrect safety code is entered once again, the navigation system is blocked for 1 hour.*
- ◆ *After one hour has elapsed, during which the navigation system as well as the ignition must remain switched on (the time which has elapsed since the lock was activated is shown in the display of the navigation system), the procedure for deactivating the electronic anti-theft coding can be repeated (always two attempts, then locked for one hour).*

### 2.3.2 Electronic anti-theft coding - Amundsen infotainment unit as of CW 45.2014

The Amundsen infotainment unit (hereafter, the Infotainment unit) is equipped with electronic comfort anti-theft coding, which operates in combination with the dash panel insert.

The Infotainment unit must be paired with an appropriate vehicle using the ⇒ Vehicle diagnostic tester. The security code is no longer entered.

The Infotainment unit, which is assembled at the factory, is paired only when it is used for the first time with the corresponding vehicle. If the battery is disconnected and then reconnected or if the Infotainment unit is removed from a vehicle and then re-installed in the same vehicle, pairing with the corresponding vehicle is no longer valid.

If the dash panel insert is replaced, the Infotainment unit must be paired with the relevant vehicle once again.

The user must have valid authorisation to use a programme to pair the Infotainment unit.

Additional information ⇒ Amundsen Infotainment operating manual .

### 2.4 Overall view of the navigation system

The number and the design of the components depend on the vehicle equipment and on the model year.





**1 - Front bass speaker**

- Removing and installing  
⇒ [“7.1 Removing and installing the front and rear bass speaker”](#), page 68

**2 - Front treble speaker**

- in the front door trim panel
- Removing and installing  
⇒ [“7.4 Removing and installing the front and rear treble speaker”](#), page 69

**3 - GPS aerial**

- from CW 22.2015 to CW 36.2015, installed in vehicles with navigation system without heated windscreen
- from CW 37.2015, part of the roof aerial (Pos. 12)
- Removing and installing  
⇒ [“4.5 Removing and installing the GPS aerial under the dash panel”](#), page 58

**4 - Multi-functional steering wheel**

- Description and body work  
⇒ [“5 Multi-functional steering wheel”](#), page 59

**5 - Navigation system**

- installed in the dash panel
- Removing and installing ⇒ [“2.5 Removing and installing the navigation system”](#), page 47

**6 - Multimedia socket MEDIA-IN / AUX, USB**

- with control unit for multimedia system - J650- (no longer in use as of CW 45.2014)
- in the centre console under the heating/air conditioning control
- Removing and installing multimedia socket  
⇒ [“10 Multimedia socket MEDIA-IN \(MDI\) with control unit for multimedia system J650”](#), page 73
- Removing and installing connection for external audio sources and USB connection  
⇒ [“9 Connection for external audio sources R199”](#), page 71

**7 - Connection for external audio sources**

- in the centre console in the storage compartment under the armrest of the driver
- Removing and installing ⇒ [“9 Connection for external audio sources R199”](#), page 71

**8 - Rear treble speaker**

- in the rear door trim panel
- Removing and installing ⇒ [“7.4 Removing and installing the front and rear treble speaker”](#), page 69

**9 - Rear bass speaker**

- Removing and installing ⇒ [“7.1 Removing and installing the front and rear bass speaker”](#), page 68

**10 - CD changer**

- is located in the left luggage compartment

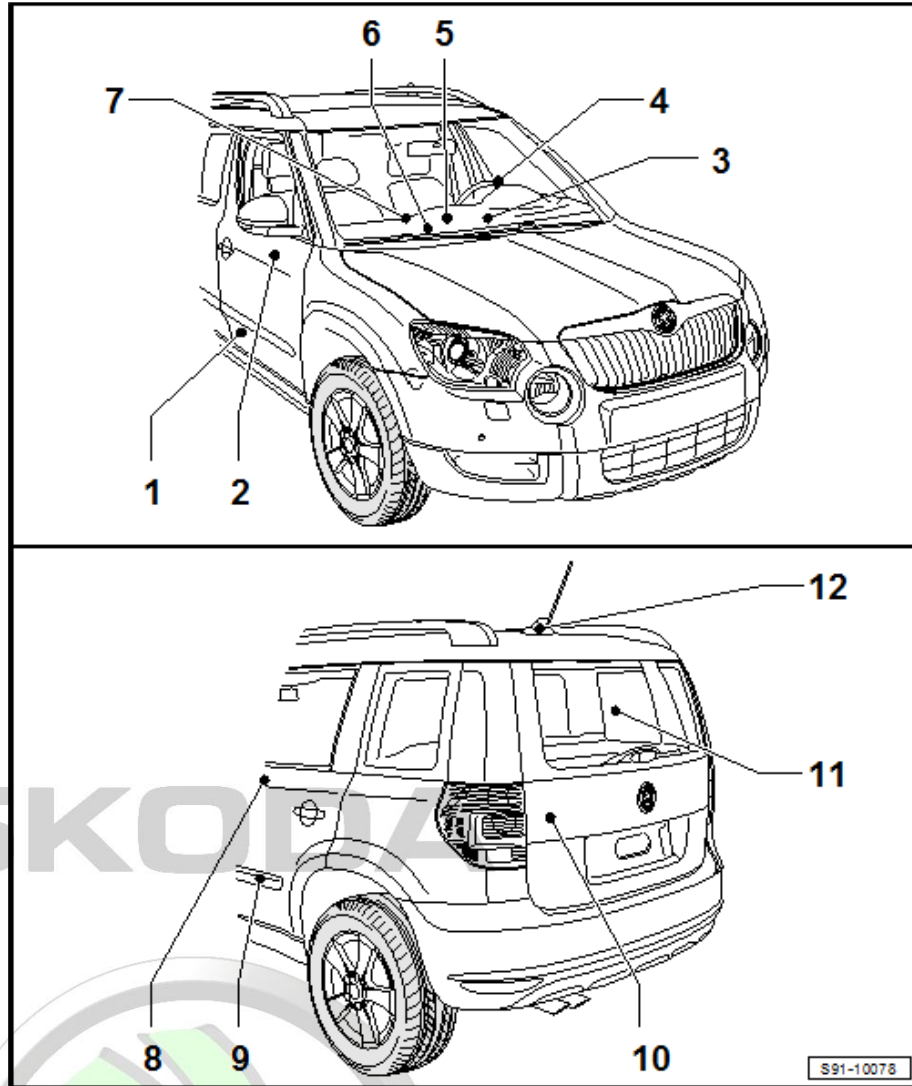

- ❑ Removing and installing ⇒ [“8 CD changer”, page 70](#)
- ❑ Contact assignment on the CD changer ⇒ [“8.2 Plug connection on the CD changer”, page 70](#)

### 11 - Rear window aerial

- ❑ Removing and installing ⇒ Body Work; Rep. gr. 64

### 12 - Roof aerial

- ❑ Removing and installing ⇒ [“4 Aerial systems”, page 54](#)

## 2.5 Removing and installing the navigation system

### Removing

- Remove all data media/audio media (SD card, CD) from the navigation system ⇒ Navigation system operating instructions .
- Switch off the navigation system, the ignition and all electrical consumers.
- Slacken the frame out of the pegs -3- using the disassembly wedge - 3409- .
- Unscrew the fixing screws -2- and pull the -1- navigation system out of the dash panel.

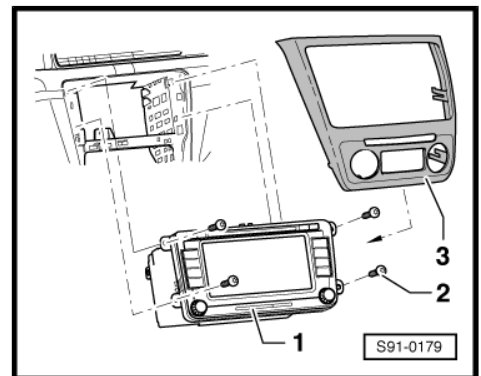

- Compress plug catch -arrows-.

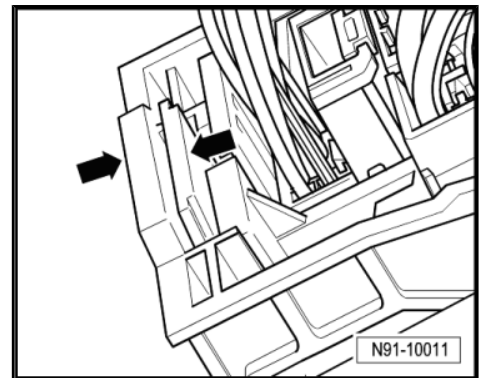

- Open catch clamp -arrow- and disconnect plug.

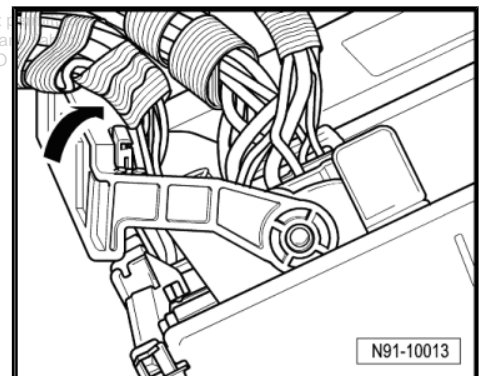



- Release plug of antenna socket -arrows- and disconnect.
- Unlock and remove other connectors.

### Install

Installation is performed in the reverse order, pay attention to the following points:



#### Note

*When pushing the navigation system in, do not in any circumstances press on the display or operating buttons. The navigation system may be damaged.*

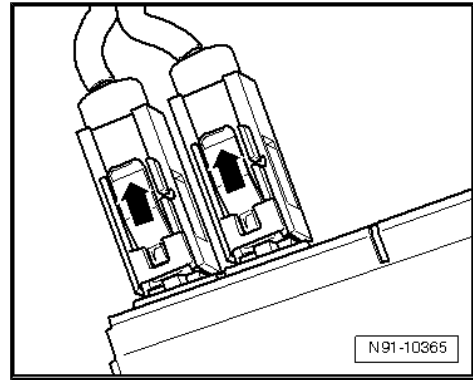

If the navigation system was replaced:

- Adapt the navigation system  
⇒ ["2.3 Electronic anti-theft coding", page 44](#) and code with  
⇒ Vehicle diagnostic tester.

### Tightening torques

Fixing screws for navigation system	1.5 Nm
-------------------------------------	--------

## 2.6 Self-diagnosis of the navigation system

Carry out "self-diagnosis" with the ⇒ Vehicle diagnostic tester in the function "Targeted fault finding".



Protected by copyright. Copying for private or commercial purposes, in part or in whole, is not permitted unless authorised by ŠKODA AUTO A. S. ŠKODA AUTO A. S. does not guarantee or accept any liability with respect to the correctness of information in this document. Copyright by ŠKODA AUTO A. S. ©

## 3 Telephone system

⇒ [“3.1 General points”, page 49](#)

⇒ [“3.2 Universal mobile phone pre-installation GSM II”, page 50](#)

⇒ [“3.3 Universal mobile phone pre-installation GSM III”, page 51](#)

⇒ [“3.4 Removing and installing the microphone for the telephone R38”, page 51](#)

⇒ [“3.5 Removing and installing the mount for the mobile phone”, page 51](#)

⇒ [“3.6 Removing and installing the control unit for the mobile phone operating electronics J412”, page 52](#)

### 3.1 General points

The mobile phone pre-installation is supplied in two versions:

- ◆ Universal mobile phone pre-installation GSM II
- ◆ Universal mobile phone pre-installation GSM III

The mobile phone pre-installation is only delivered together with the radio/navigation.

Additional information and description of function:

- ◆ ⇒ Owner's manual Yeti
- ◆ ⇒ Self-study programme No. 72 ; Škoda Yeti, introduction of the vehicle
- ◆ ⇒ Self-study programme No. 81 ; Bluetooth in Škoda vehicles



#### Note

*When handling a fault it is absolutely essential to know the functions and the operation of the telephone system.*

#### Fault finding

The mobile phone pre-installations are fitted with self-diagnosis.

For fault finding use the ⇒ Vehicle diagnostic tester in the function “Targeted fault finding”.

ŠKODA

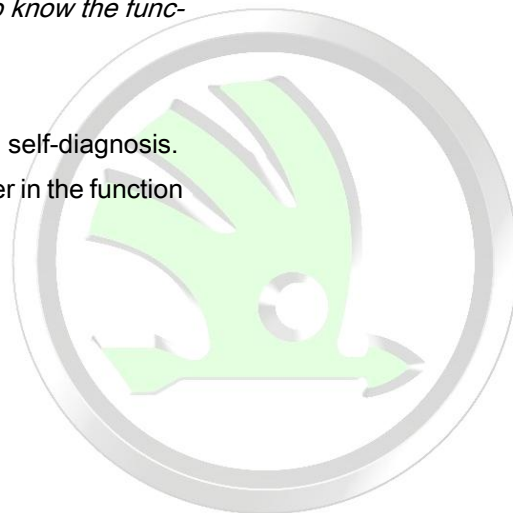



### 3.2 Universal mobile phone pre-installation GSM II



**Note**

- ◆ A Bluetooth module is integrated into the Amundsen+ unit as of CW 22.2011 and into the Amundsen and Bolero units as of CW 45.2014, which fulfils the function of the mobile phone pre-installation. In vehicles with these units, the control unit for the mobile phone operating electronics - J412- (Pos. 10) is not installed separately.
- ◆ As of CW 22.2015, a Bluetooth module can be integrated into the Swing infotainment unit (depending on equipment), which fulfils the function of the mobile phone pre-installation.
- ◆ The wiring harness of the microphone Pos. -4-, gateway control unit Pos. -2- and of the mobile phone holder (if present) Pos. -11- leads directly into the navigation system/radio, see ⇒ Current flow diagrams, Electrical fault finding and Fitting locations.

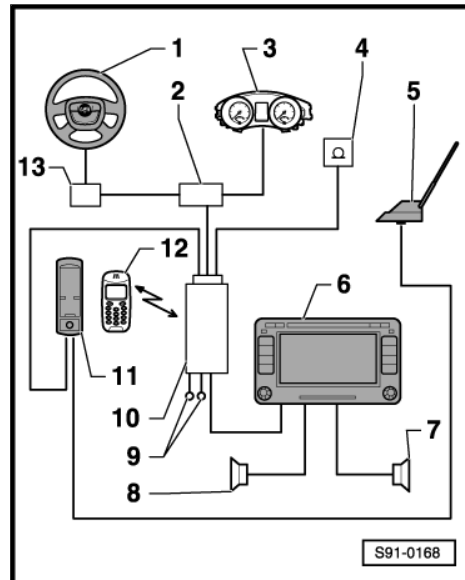

- 1 - Multi-function steering wheel - optional
- 2 - Data bus diagnostic interface Gateway - J533-
- 3 - Control unit in dash panel insert - J285-
- 4 - Microphone for the telephone - R38- - in the front interior light
- 5 - Roof aerial
- 6 - Radio/Navigation/Infotainment unit
- 7 - Loudspeaker arrangement - right side
- 8 - Loudspeaker arrangement - left side
- 9 - Voltage supply of the control unit for the mobile phone operating electronics - J412-
- 10 - Control unit for the mobile phone operating electronics - J412-
- 11 - Phone holder with adapter - optional - for recharging and for amplifying the aerial signal
- 12 - Mobile phone data transmission between phone and transmission/receiver unit via Bluetooth communication or mobile phone holder.
- 13 - Steering column electronics control unit - J527-

Protected by copyright. Copying for private or commercial purposes, in part or in whole, is not permitted. ŠKODA AUTO A. S. does not guarantee or accept any liability with respect to the correctness of information in this document. Copyright by ŠKODA AUTO A. S. ©



### 3.3 Universal mobile phone pre-installation GSM III

- 1 - Control unit in dash panel insert - J285-
- 2 - Multi-functional steering wheel
- 3 - Steering column electronics control unit - J527-
- 4 - Roof aerial
- 5 - Data bus diagnostic interface Gateway - J533-
- 6 - Voltage supply of the control unit for the mobile phone operating electronics - J412-
- 7 - Control unit for the mobile phone operating electronics - J412- (as of CW 45.2014, not installed separately and functions provided by infotainment unit, Pos. -13-)
- 8 - Notebook, Laptop (is not a component part of the preinstallation)
- 9 - Headset unit - enables private phone calls in the vehicle (is not a component part of the preinstallation)
- 10 - Mobile phone
- 11 - Microphone for the telephone - R38- - in the front interior light
- 12 - Loudspeaker arrangement - left side
- 13 - Radio/navigation
- 14 - Loudspeaker arrangement - right side

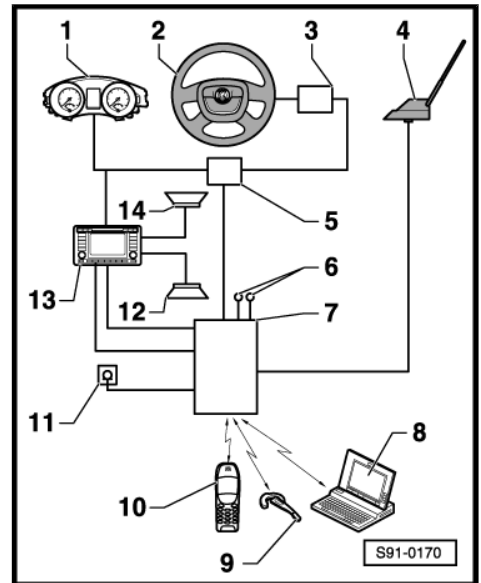

### 3.4 Removing and installing the microphone for the telephone - R38-

#### Removing

- Remove front interior light  
 => ["1.1 Removing and installing the front interior light", page 187](#) .
- Slacken the microphone out of the retaining lugs -arrows- and remove.
- Disconnect plug.

#### Install

Installation is carried out in the reverse order.

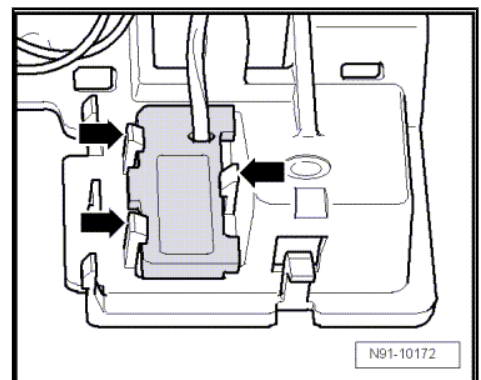

### 3.5 Removing and installing the mount for the mobile phone

#### Removing

- Switch off the ignition and all electrical components.
- Remove the centre vent from the dash panel => Heating, Air Conditioning; Rep. gr. 80 .
- Take the mobile phone and the adapter out of the mount.



- Use a small screwdriver to release the upper cover -5- of the phone holder from the catches.
- Disconnect plug of aerial cable -2- and plug -1-.
- Put hand through the dash panel opening and hold the base with nuts behind the phone holder.
- Unscrew fixing screws -4-.
- Remove the phone holder -3- and the base with nuts.

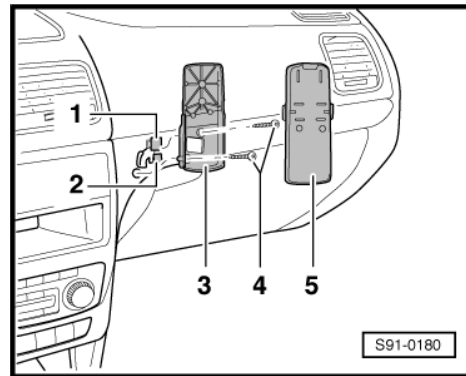

**Install**

Installation is carried out in the reverse order.

**Tightening torques**

Fixing screws for mount for mobile phone	1.5 Nm
--	--------

### 3.6 Removing and installing the control unit for the mobile phone operating electronics - J412-

The control unit for the mobile phone operating electronics - J412- is located below the right front seat.



**Note**

*A Bluetooth module is integrated into the Amundsen+ unit as of CW 22.2011 and into the Amundsen and Bolero units as of CW 45.2014, which fulfils the function of mobile phone pre-installation. In vehicles with these units, the control unit for the mobile phone operating electronics - J412- is not installed separately.*

**Removing**

- Switch off all electrical components and take out the ignition key.
- Push the right front seat completely towards the rear and the highest point.
- Lightly raise the edges of the cover in the direction of arrow -A- and remove cover in direction of arrow -B-.

GSM II up to CW 21.2010

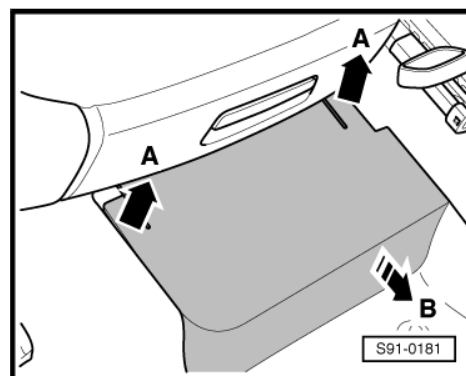
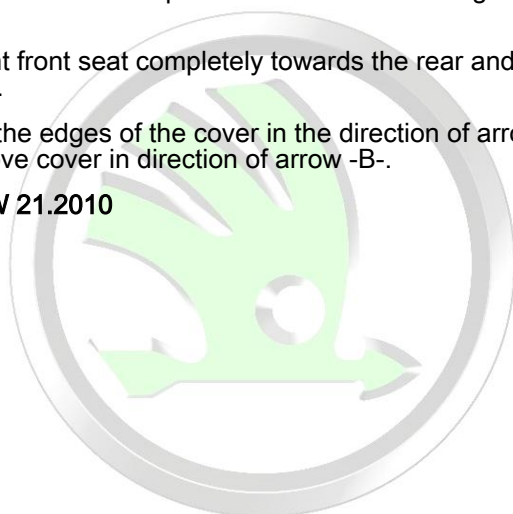

Protected by copyright. Copying for private or commercial purposes, in part or in whole, is not permitted unless authorised by ŠKODA AUTO A. S. ŠKODA AUTO A. S. does not guarantee or accept any liability with respect to the correctness of information in this document. Copyright by ŠKODA AUTO A. S. ©



- Unscrew bolt -4-.
- Slightly tilt out the holder for control unit -5- in direction of arrow -A- and remove control unit -3- in direction of arrow -B-.
- Unlock by tilting out the clamp -2- and disconnect the plug connection -1-.

**GSM II as of CW 22.2010 and GSM III**

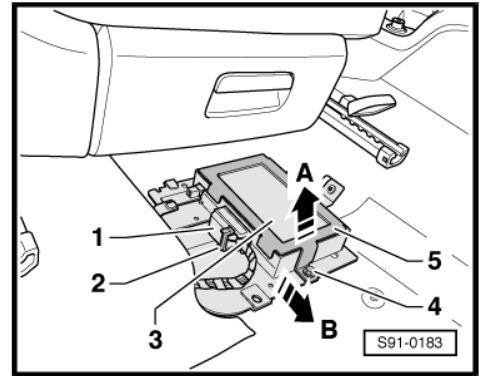

- Release screws -arrows-.

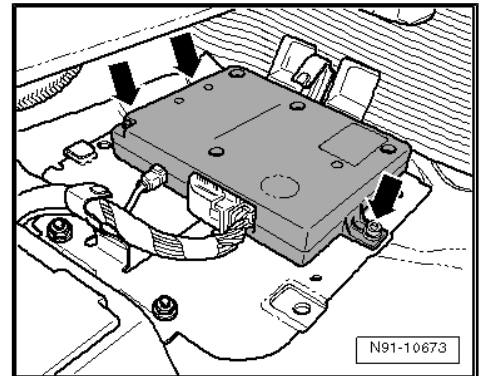

- Press the catch -A- and disconnect the plug connection by tilting out the clamp arrow -B-.
- Unlock the plug of the aerial cable -arrows- and detach.

**Install**

Installation is performed in the reverse order, pay attention to the following points:

- When replacing, code the new control unit after the installation => Vehicle diagnostic tester.

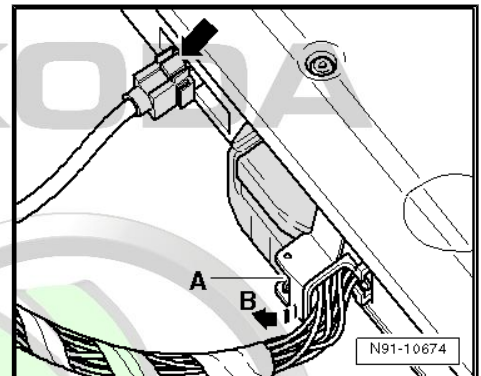

**Tightening torques**

Fixing screw for GSM II up to CW 21.2010	6 Nm
Fixing screw for GSM II from CW 22.2010	3 Nm

Protected by copyright. Copying for private or commercial purposes, in part or in whole, is not permitted unless authorised by ŠKODA AUTO A. S. ŠKODA AUTO A. S. does not guarantee or accept any liability with respect to the correctness of information in this document. Copyright by ŠKODA AUTO A. S. ©



## 4 Aerial systems

⇒ [“4.1 Overview of the aerial systems”, page 54](#)

⇒ [“4.2 Roof aerial for radio”, page 56](#)

⇒ [“4.3 Roof aerial for radio, telephone and navigation system”, page 56](#)

⇒ [“4.4 Removing and installing aerial module R108”, page 57](#)

⇒ [“4.5 Removing and installing the GPS aerial under the dash panel”, page 58](#)

⇒ [“4.6 Replacing aerial cables”, page 58](#)

### 4.1 Overview of the aerial systems



#### Note

◆ *The number of components of the aerial system depends on the vehicle equipment.*

◆ *Further description ⇒ Self-study programme No. 72: Škoda Yeti, introduction of the vehicle*

#### 1 - Control unit for the mobile phone operating electronics - J412-

- ❑ A Bluetooth module is integrated into the Amundsen+ unit as of CW 22.2011 and into the Amundsen and Bolero units as of CW 45.2014, which fulfils the function of GSM II mobile phone pre-installation. In vehicles with these units, the control unit for the mobile phone operating electronics - J412- is not installed separately. The control unit for the mobile phone operating electronics - J412- Pos. -1- is still installed separately for the GSM III mobile phone pre-installation up to CW 44.2014.

- ❑ Removing and installing ⇒ [“3.6 Removing and installing the control unit for the mobile phone operating electronics J412”, page 52](#)

#### 2 - Mount for mobile phone

- ❑ Removing and installing ⇒ [“3.5 Removing and installing the mount for the mobile phone”, page 51](#)

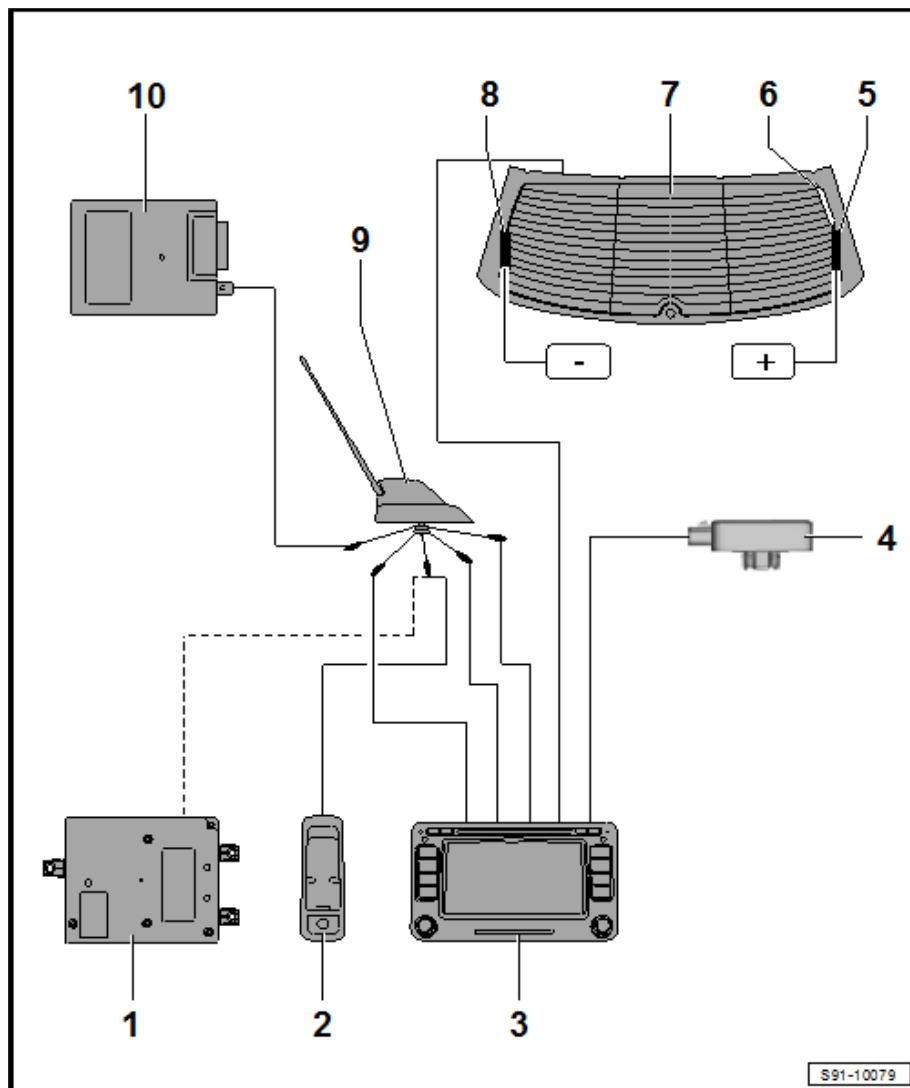

### 3 - Radio/navigation system

#### 4 - GPS aerial

- from CW 22.2015 to CW 36.2015, installed in vehicles with navigation system without heated windscreen
- from CW 37.2015, part of the roof aerial (Pos. 9)
- Removing and installing  
⇒ ["4.5 Removing and installing the GPS aerial under the dash panel", page 58](#)

#### 5 - Frequency filter for the frequency modulation (FM) in the positive cable - R179-

- installed in the wiring harness
- only on vehicles with rear window aerial

#### 6 - Aerial module - R108- (amplifier)

- Removing and installing ⇒ ["4.4 Removing and installing aerial module R108 ", page 57](#)

#### 7 - Rear window aerial -R130-

- for radios with two tuners (two antenna sockets)

#### 8 - Frequency filter for the frequency modulation (FM) in the negative cable - R178-

- installed in the wiring harness
- only on vehicles with rear window aerial

#### 9 - Roof aerial

- different in shape depending on the model year and equipment

#### 10 - Auxiliary heating radio controlled receiver - R64-

- removing and installing ⇒ Heating, Air Conditioning; Rep. gr. 82



## 4.2 Roof aerial for radio

### 1 - Aerial rod

- screwable
- as of CW 45.2010 shorter

### 2 - Aerial base with integrated amplifier

- To remove and install:  
unhook headliner ⇒  
Body Work; Rep. gr. 70

### 3 - Connection for the antenna cable going to the radio

### 4 - Hexagon nut with serrated washer

- 6 Nm
- hexagonal nut is connected to serrated washer by a plastic ring
- apply contact grease on the inside of roof in the area of the serrated washer

### 5 - Roof

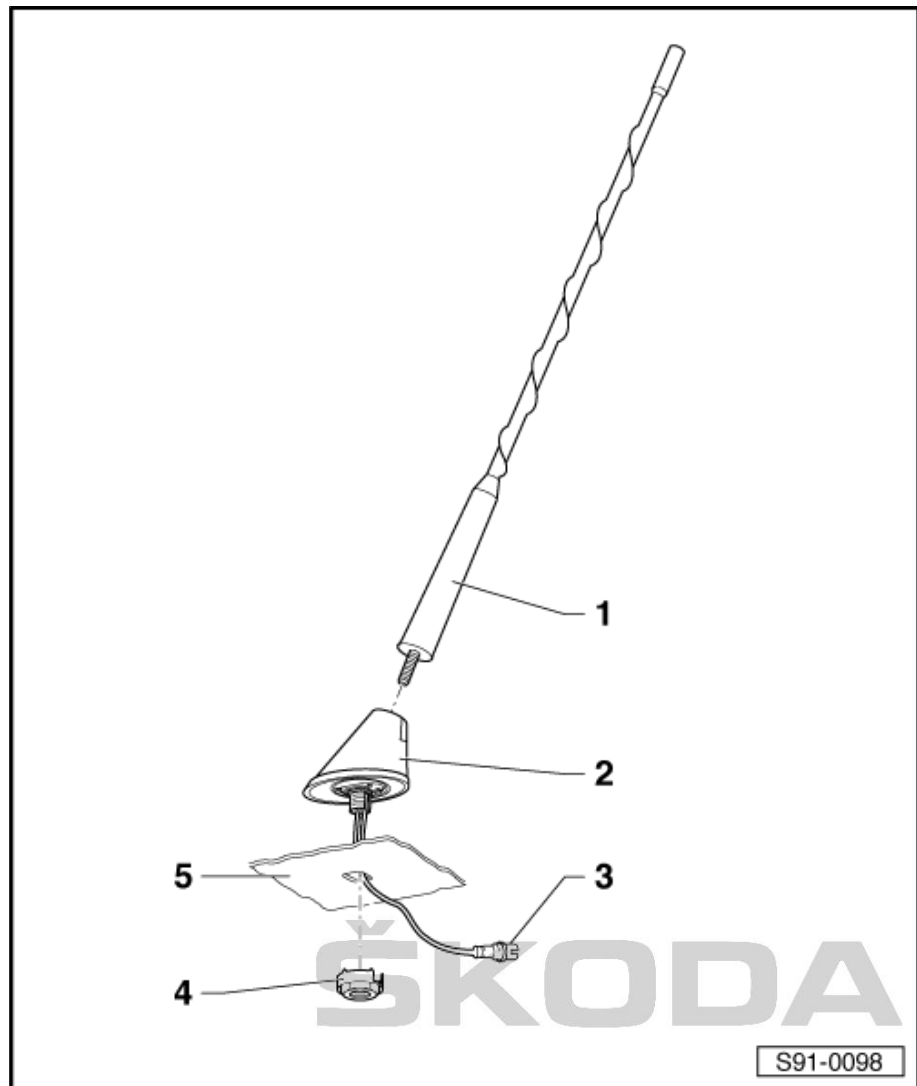

## 4.3 Roof aerial for radio, telephone and navigation system



### Note

*The number of connections of the aerial base depends on the vehicle equipment.*





**1 - Aerial rod**

- screwable
- as of CW 45.2010 shorter

**2 - Aerial base with integrated amplifier**

- To remove and install:  
unhook headliner =>  
Body Work; Rep. gr. 70

**3 - Hexagon nut with serrated washer**

- 6 Nm
- hexagonal nut is connected to serrated washer by a plastic ring
- apply contact grease on the inside of roof in the area of the serrated washer

**4 - Aerial cable to telephone**

- Lilac plug

**5 - Aerial cable to radio**

- White plug

**6 - Aerial cable to Telestart (operation of the auxiliary heating)**

- Beige plug

**7 - Aerial cable to navigation**

- Blue plug

**8 - Aerial cable to radio**

- black plug
- Reception of digital programme

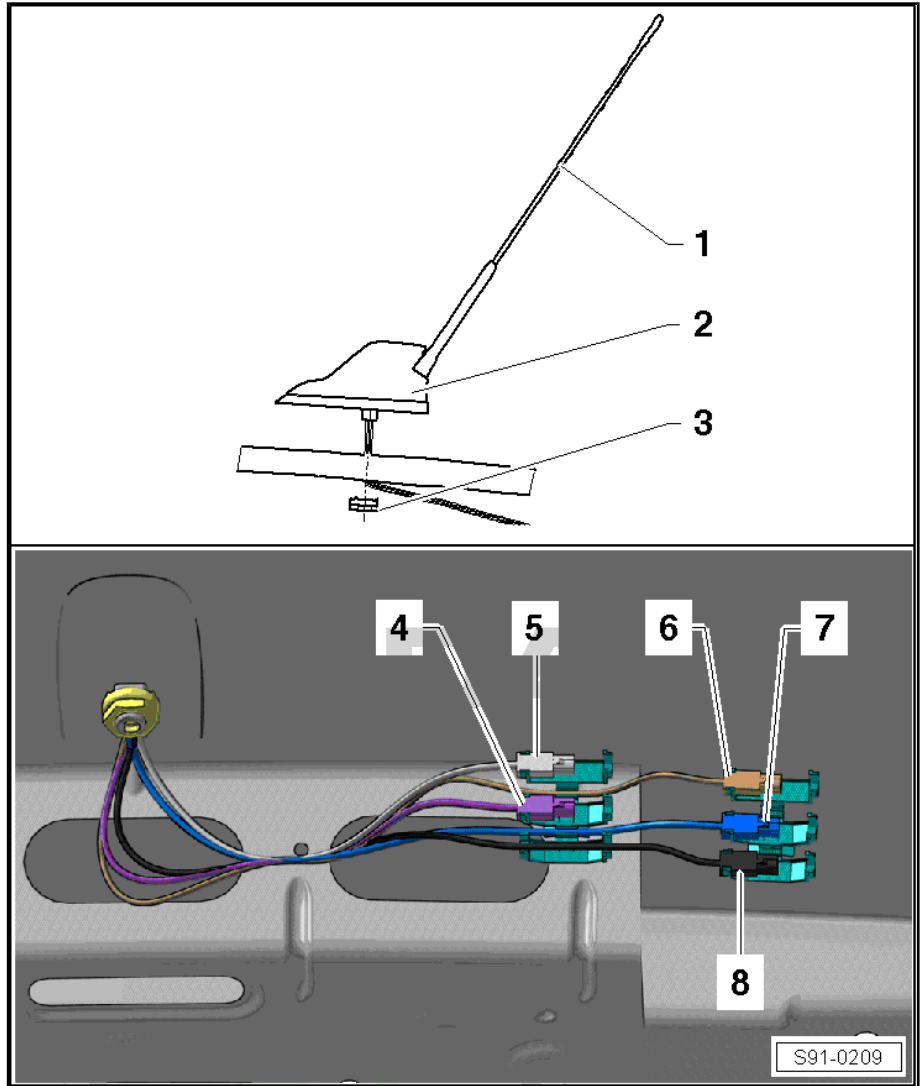

## 4.4 Removing and installing aerial module - R108-

### Removing

- Remove the top tailgate trim panel => Body Work; Rep. gr. 70 .
- Carefully disconnect plug of aerial cable -1- and plug -3- from aerial module -2-.
- Unscrew screw -4- but not fully.
- Slightly tilt out the aerial module -2- in the direction of arrow -A-, move in the direction of arrow -B- and unhook from bracket of tailgate.

### Install

Installation is carried out in the reverse order.

### Tightening torques

Screw, Pos. -4-	1.5 Nm
-----------------	--------

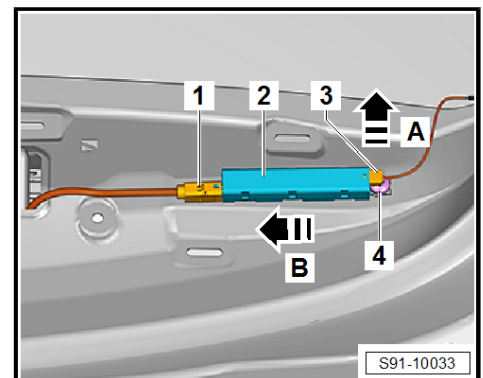



## 4.5 Removing and installing the GPS aerial under the dash panel

### Removing

- Removing the dash panel ⇒ Body Work; Rep. gr. 70 .
- Unscrew and remove screw/right-hand drive nut -2- and remove bracket -3- with aerial -1-.

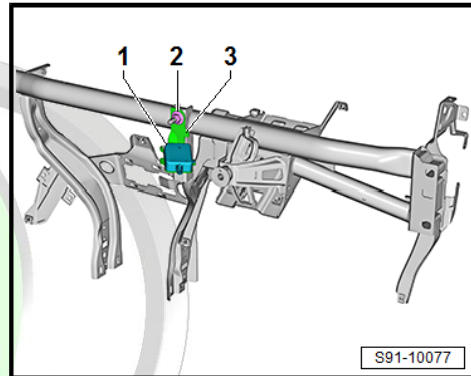

- When pressing the aerial off the support, press the retaining tabs -arrows-.
- Unlock and remove the aerial connection.

### Install

Installation is performed in the reverse order, pay attention to the following points:

- The aerial nose, see fig., locks the correct position.
- Press the aerial into the assembly opening until it audibly locks into place.

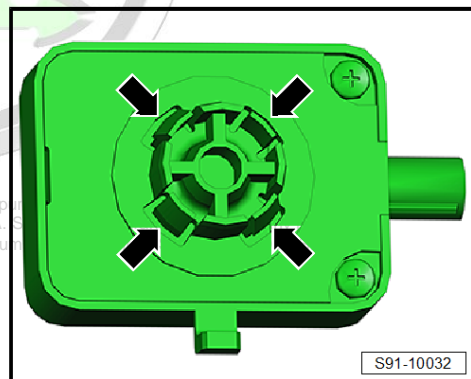

### Tightening torques

Screw/nut, Pos. -2-	10 Nm
---------------------	-------

## 4.6 Replacing aerial cables



### Note

- ◆ *Aerial cables must not be repaired, but replaced with a new original part see ⇒ Electronic Catalogue of Original Parts ; Accessories; Part group 35.*
  - ◆ *Do not crimp aerial cable or bend excessively! The minimum bending radius must not be less than 50 mm.*
  - Cut off aerial connection from the defective cable.
- The remainder of the defective cable remains in the vehicle.
- Lay new aerial cable close to the original cable and attach.
  - Perform a functional test.

## 5 Multi-functional steering wheel

⇒ [“5.1 General description”, page 59](#)

⇒ [“5.2 Multifunctional steering wheel up to MY 2013”, page 60](#)

⇒ [“5.3 Multifunctional steering wheel as of MY 2014”, page 61](#)

⇒ [“5.4 Diagnosis of the multi-functional steering wheel”, page 63](#)

### 5.1 General description



#### Note

- ◆ *When handling a fault it is absolutely essential to know the function and operation of the multi-functional steering wheel. Additional information and description of function ⇒ Owner's manual Yeti .*
- ◆ *Additional information and description of function ⇒ Owner's manual Yeti .*

#### General description

The multi-functional steering wheel contains (depending upon equipment) the following components:

- ◆ Switch unit left ( -E440- ) and right ( -E441- ) on the steering wheel front for audio and mobile phone operation.
- ◆ Key module on the left ( -E439- - shifting down) and right ( -E438- - shifting up) on the rear of the steering wheel for the gearbox operation in the Tiptronic mode (gearbox DSG).
- ◆ Wiring harness.
- ◆ Multi-functional steering wheel control unit - J453- , integrated in the left front switch unit.

The multi-functional steering wheel control unit communicates with the steering column electronics control unit. Here the data commands are once again controlled for further communication.

#### Versions of the multi-functional steering wheel:

- 1 - Four-spoke steering wheel
  - for audio
  - for audio und telephone
- 2 - Three-spoke steering wheel
  - for audio
  - for audio und telephone
- 3 - Three-spoke steering wheel
  - for audio, telephone and gearbox operation in the Tiptronic mode (gearbox DSG)

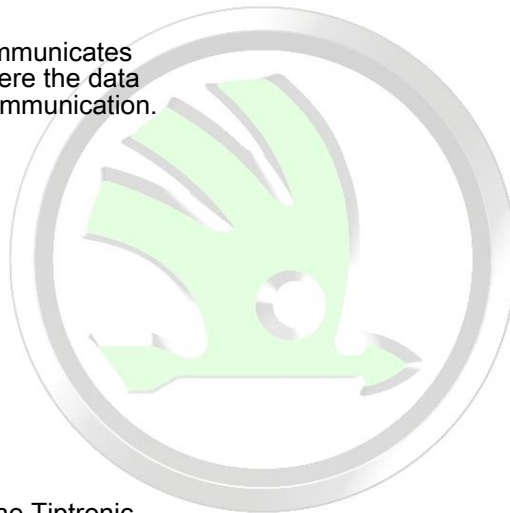

Protected by copyright. Copying for private or commercial purposes, in part or in whole, is not permitted unless authorised by ŠKODA AUTO A. S. ŠKODA AUTO A. S. does not guarantee or accept any liability with respect to the correctness of information in this document. Copyright by ŠKODA AUTO A. S. ©



## 5.2 Multifunctional steering wheel up to MY 2013

⇒ [“5.2.1 Removing and installing switch units for operating the audio and phone”, page 60](#)

⇒ [“5.2.2 Removing and installing switch units for gearbox operation in Tiptronic mode \(gearbox DSG\)”, page 60](#)

### 5.2.1 Removing and installing switch units for operating the audio and phone

The mounting sequence is identical for both key modules.

#### Removing

- Remove the airbag unit in the steering wheel ⇒ Body Work; Rep. gr. 69 .
- Clear away wiring harness -arrows- and disconnect plug connection -1- from the switch unit.

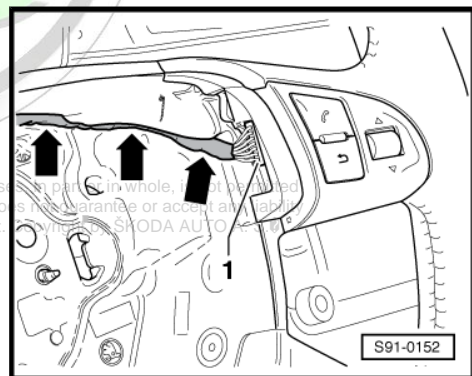

Protected by copyright. Copying for private or commercial purposes in whole or in part is prohibited unless authorised by ŠKODA AUTO A. S. ŠKODA AUTO A. S. does not guarantee or accept any liability with respect to the correctness of information in this document. ŠKODA AUTO A. S.

- Swivel out the switch unit -2- -arrow- until the locking bolts -1- become loose, push it slightly and pull it out.

#### Install

Installation is performed in the reverse order, pay attention to the following points:



#### Note

- ◆ *Before the airbag is installed, it must be checked if all the wiring is properly pressed back into the guiding grooves in the steering wheel foam. Wiring which protrudes can be damaged by the backside parts of the airbag.*
- ◆ *Pay attention to the work sequence when connecting the battery ⇒ [“1.1 Disconnecting and reconnecting battery”, page 5](#) .*
- If the left switch unit has been replaced by an integrated control unit, coding must be performed with ⇒ Vehicle diagnostic tester.

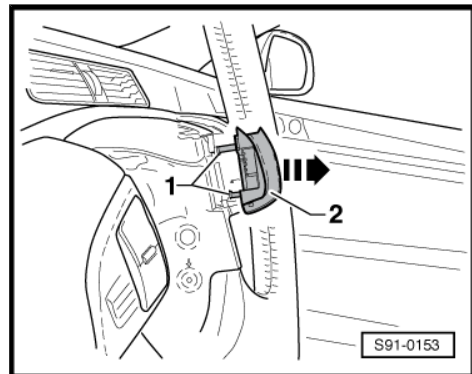

### 5.2.2 Removing and installing switch units for gearbox operation in Tiptronic mode (gearbox DSG)

The mounting sequence is identical for both key modules.

#### Removing

- Remove the airbag unit in the steering wheel ⇒ Body Work; Rep. gr. 69 .



- Disconnect plug connection -2-.
- Unscrew screw -1-, then swivel out and carefully remove the switch unit for gearbox operation -3- -arrow-.

### Install

Installation is performed in the reverse order, pay attention to the following points:

### Note

- ◆ Before the airbag is installed, it must be checked if all the wiring is properly pressed back into the guiding grooves in the steering wheel foam. Wiring which protrudes can be damaged by the backside parts of the airbag.
- ◆ Pay attention to the work sequence when connecting the battery ⇒ ["1.1 Disconnecting and reconnecting battery", page 5](#).

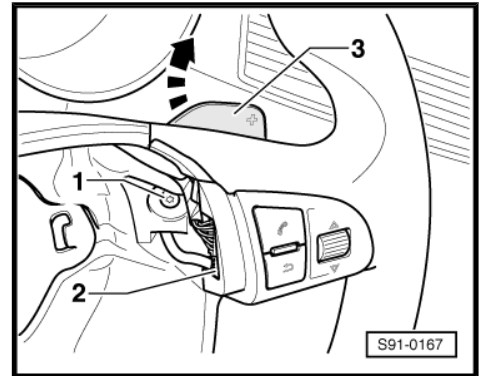

### Tightening torques

Screw, Pos. -1-	1.5 Nm
-----------------	--------

## 5.3 Multifunctional steering wheel as of MY 2014

⇒ ["5.3.1 Removing and installing switch units for operating the audio and phone", page 61](#)

⇒ ["5.3.2 Removing and installing switch units for gearbox operation in Tiptronic mode \(gearbox 02E, 0AM – DSG\)", page 62](#)

### 5.3.1 Removing and installing switch units for operating the audio and phone

The installation work for both switch units is identical.

#### Removing

- Remove the airbag unit in the steering wheel ⇒ Body Work; Rep. gr. 69 .
- Prise out the plate with switch units -2- evenly and carefully out of the steering wheel -1- using the disassembly wedge -arrows-.
- Disconnect plug.

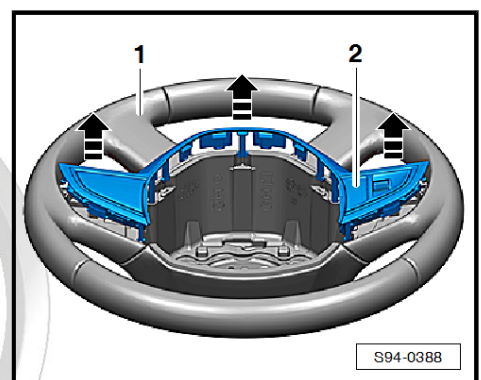



- Unscrew screws -3-.
- When removing the units -1- and -2-, carefully detach the connecting cable from the bearing -arrows-.
- Vehicles with automatic gearbox with steering column gearshift - disconnect plugs from switch units.

**Install**

Installation is performed in the reverse order, pay attention to the following points:



**Note**

- ◆ Route connection cable for modules correctly in the line in the plate -arrows-.
- ◆ Before the airbag is installed, it must be checked if all the wiring is properly pressed back into the guiding grooves in the steering wheel foam. Wiring which protrudes can be damaged by the backside parts of the airbag.
- ◆ Pay attention to the work sequence when connecting the battery ⇒ ["1.1 Disconnecting and reconnecting battery", page 5](#).

Perform coding with ⇒ Vehicle diagnostic tester when replacing the switch units.

**Tightening torques**

Screws, Pos. -3-	0.4 Nm
------------------	--------

**5.3.2 Removing and installing switch units for gearbox operation in Tiptronic mode (gearbox 02E, 0AM – DSG)**

The mounting sequence is identical for both key modules.

**Removing**

- Remove the airbag unit in the steering wheel ⇒ Body Work; Rep. gr. 69 .
- Prise out the plate with switch units -2- evenly and carefully out of the steering wheel -1- using the disassembly wedge -arrows-.
- Disconnect plug.

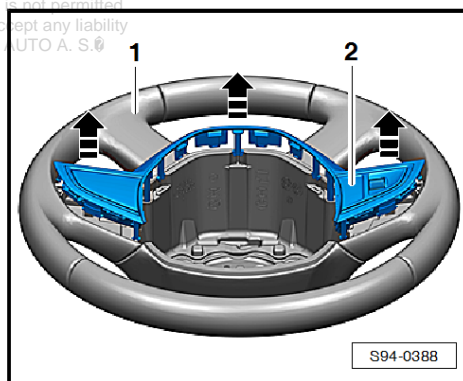
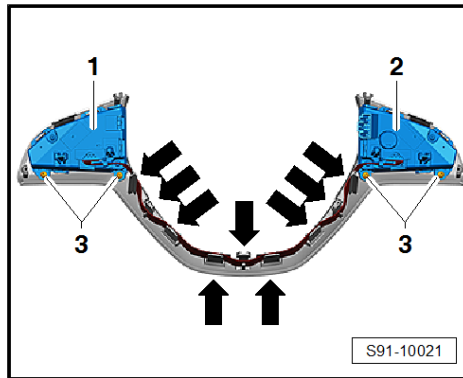



- Unscrew the screw, arrow -A-, then swivel out and remove the switch unit for gearbox operation -1- in direction of arrow -B-.

### Install

Installation is performed in the reverse order, pay attention to the following points:



#### Note

- ◆ Before the airbag is installed, it must be checked if all the wiring is properly pressed back into the guiding grooves in the steering wheel foam. Wiring which protrudes can be damaged by the backside parts of the airbag.
- ◆ When tightening the screw -A- keep the button -1- in the right position (edge of the button -1- on a line with the edge of the steering wheel).
- ◆ Pay attention to the work sequence when connecting the battery ⇒ ["1.1 Disconnecting and reconnecting battery", page 5](#).

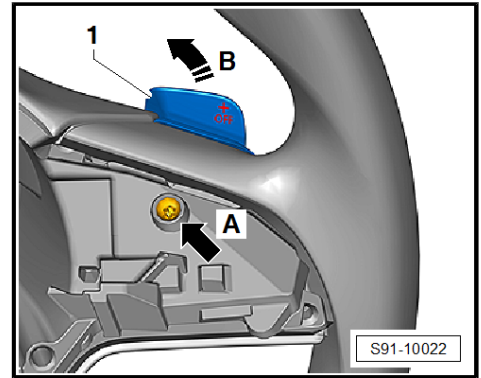

### Tightening torques

Screw, arrow -A-	1.7 Nm
------------------	--------

## 5.4 Diagnosis of the multi-functional steering wheel

The multi-functional steering wheel is capable of conducting a self-diagnosis. Carry out "self-diagnosis" with the ⇒ Vehicle diagnostic tester in the function "Targeted fault finding".

# ŠKODA



Protected by copyright. Copying for private or commercial purposes, in part or in whole, is not permitted unless authorised by ŠKODA AUTO A. S. ŠKODA AUTO A. S. does not guarantee or accept any liability with respect to the correctness of information in this document. Copyright by ŠKODA AUTO A. S. ©



## 6 Sound system

⇒ [“6.1 General description”, page 64](#)

⇒ [“6.2 Removing and installing the control unit for the digital sound package J525”, page 64](#)

⇒ [“6.3 Contact assignment of the 38-pin plug connection for amplifier”, page 66](#)

⇒ [“6.4 Removing and installing loudspeakers”, page 67](#)

### 6.1 General description

The basis of this system is the control unit for the digital sound package - J525- with ten channel audio amplifier. The loudspeaker arrangement is designed in three zones. Except bass speaker and treble speaker, the sound system is additionally fitted out with midrange speakers which are installed in the front and rear doors. Altogether the sound system is fitted out with twelve loudspeakers.

The sound system version is marked at the front door trim panel with the logo “SOUND SYSTEM” and is an equipment version for vehicles with radio “Bolero” and navigations “Amundsen” and “Columbus”.

#### Fault finding

The control unit for the digital sound package - J525- uses the CAN bus infotainment for the communication with the radio, which is also used for the self-diagnosis of the control unit for Sound-system and loudspeakers.

For fault finding use the ⇒ Vehicle diagnostic tester in the function “Targeted fault finding”.

### 6.2 Removing and installing the control unit for the digital sound package - J525-

The control unit for the digital sound package - J525- is located below the left front seat.

#### Removing

- Switch off the ignition and all electrical components.
- Push the left front seat completely towards the rear and the highest point.
- Lightly raise the edges of the cover in the direction of arrow -A- and remove cover in direction of arrow -B-.

ŠKODA

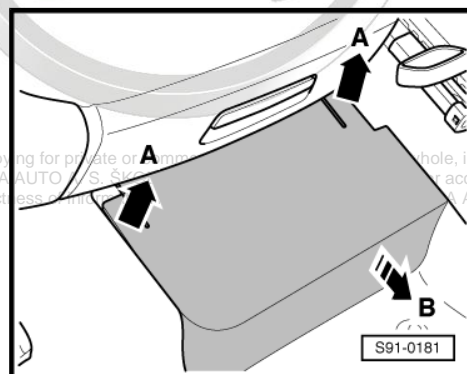

Protected by copyright. Copying for private or commercial use, in whole or in part, is not permitted unless authorised by ŠKODA AUTO A. S. ŠKODA AUTO A. S. accepts any liability with respect to the correctness of the information.



- Unscrew screws -arrows- and pull the control unit out of the bracket.
- Slacken by tilting out the clamp and separate the plug connection.

#### Install

Installation is performed in the reverse order, pay attention to the following points:

- When replacing, code the new control unit with the ⇒ Vehicle diagnostic tester.

#### Tightening torques

Fixing screws for control unit	6 Nm
--------------------------------	------

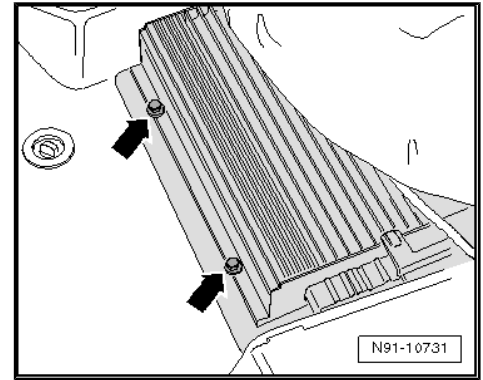

# ŠKODA





### 6.3 Contact assignment of the 38-pin plug connection for amplifier

- 1 - Terminal 31
- 2 - Terminal 30
- 3 - Midrange speaker front right -
- 4 - Bass speaker front right -
- 5 - Bass speaker front left +
- 6 - Midrange speaker front left -
- 7 - Treble speaker front right -
- 8 - Treble speaker front left +
- 9 - Bass speaker rear left +
- 10 - Bass speaker rear right -
- 11 - Treble speaker and midrange speaker rear right -
- 12 - Treble speaker and midrange speaker rear right +
- 13 - Treble speaker and midrange speaker rear left +
- 14 - Treble speaker and midrange speaker rear left -
- 15 - Midrange speaker front right +
- 16 - Bass speaker front right +
- 17 - Bass speaker front left -
- 18 - Midrange speaker front left +
- 19 - Treble speaker front right +
- 20 - Treble speaker front left +
- 21 - Bass speaker rear left -
- 22 - Bass speaker rear right +
- 23 - CAN bus Low
- 24 - not assigned
- 25 - not assigned
- 26 - not assigned
- 27 - Mono 1 left, input -
- 28 - Mono 2 right, input -
- 29 - Left stereo, input -
- 30 - Right stereo, input -
- 31 - CAN bus High
- 32 - not assigned
- 33 - not assigned
- 34 - not assigned
- 35 - Mono 1 left, input +
- 36 - Mono 2 left, input +
- 37 - Left stereo, input +
- 38 - Right stereo, input +

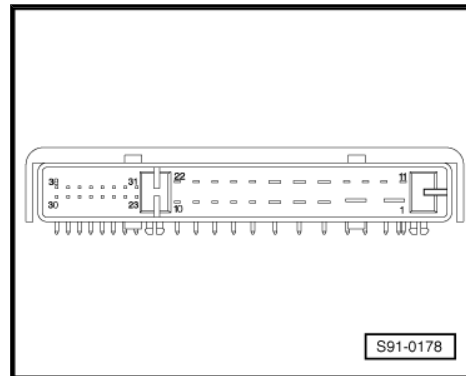



## 6.4 Removing and installing loudspeakers

Remove and install loudspeakers

⇒ ["7 Loudspeaker system", page 68](#) .



Protected by copyright. Copying for private or commercial purposes, in part or in whole, is not permitted unless authorised by ŠKODA AUTO A. S. ŠKODA AUTO A. S. does not guarantee or accept any liability with respect to the correctness of information in this document. Copyright by ŠKODA AUTO A. S. ©



## 7 Loudspeaker system

⇒ [“7.1 Removing and installing the front and rear bass speaker”, page 68](#)

⇒ [“7.2 Removing and installing the front midrange speaker”, page 68](#)

⇒ [“7.3 Removing and installing the rear midrange speaker”, page 69](#)

⇒ [“7.4 Removing and installing the front and rear treble speaker”, page 69](#)

### 7.1 Removing and installing the front and rear bass speaker



#### Note

*The rear loudspeakers are only fixed with four rivets, the mounting sequence is identical.*

#### Removing

- Switch off the ignition and all electrical components.
- Remove the door trim panel from which the loudspeaker is removed ⇒ Body Work; Rep. gr. 70 .
- Use a suitable drill to drill open the rivets -arrows- and take out the faulty speaker.



#### Note

- ◆ *It is important to remove all the drillings and the remaining rivets from the door since they can otherwise lead to corrosion and result in knocking noises.*
- ◆ *Any damage to the paintwork which is caused by drilling out the rivets must be repaired immediately by a specialist.*

#### Install

- Attach the new speaker with matching blind rivets.
- Mount the plug connection and install the door trim panel ⇒ Body Work; Rep. gr. 70 .
- Perform a functional test.

### 7.2 Removing and installing the front mid-range speaker

Only for vehicles with “Soundsystem” equipment

#### Removing

- Switch off the ignition and all electrical components.
- Remove the front door trim panel on the side of the loudspeaker to be removed ⇒ Body Work; Rep. gr. 70 .

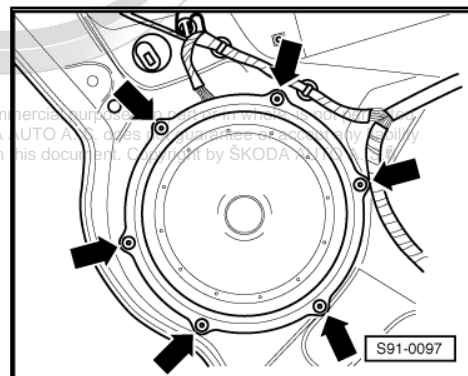



- Unscrew screws -arrows- and remove the defective speaker.

**Install**

Installation is performed in the reverse order, pay attention to the following points:

- After installing, perform a functional test.

**Tightening torques**

Screws -arrows-	0.6 Nm
-----------------	--------

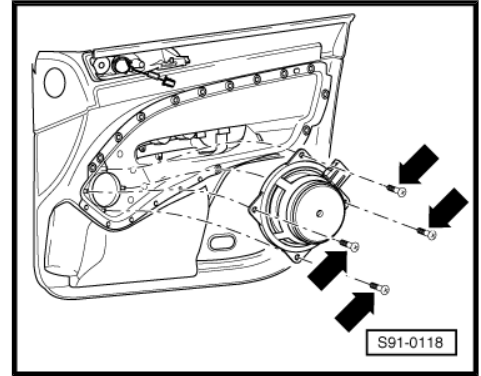

### 7.3 Removing and installing the rear mid-range speaker

Only on vehicles with the equipment "Sound system".

**Removing**

- Switch off radio/navigation.
- Remove the rear door panellings => Body Work; Rep. gr. 70 .
- Disconnect socket connector at the loudspeaker.
- Unscrew screws -arrows- and remove the defective speaker.

**Install**

Installation is performed in the reverse order, pay attention to the following points:

- After installing, perform a functional test.

**Tightening torques**

Screws -arrows-	0.6 Nm
-----------------	--------

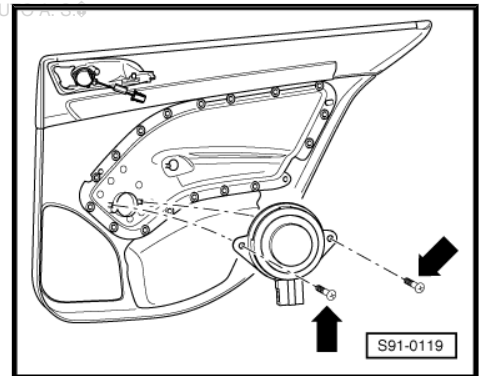

### 7.4 Removing and installing the front and rear treble speaker

The treble speakers are firmly connected with the inner door control.

In the event of a fault of the loudspeaker, remove the door trim panel => Body Work; Rep. gr. 70 , unclip and replace the inner door control -1-.

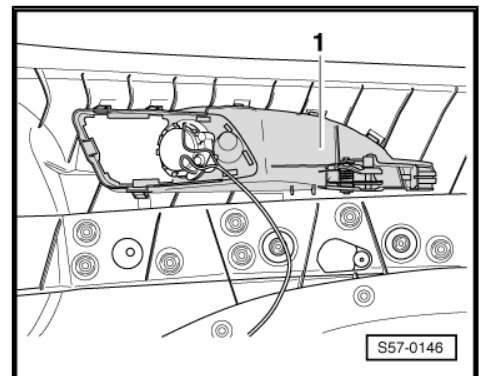

## 8 CD changer

⇒ "8.1 Removing and installing CD changer", page 70

⇒ "8.2 Plug connection on the CD changer", page 70

### 8.1 Removing and installing CD changer

#### Special tools and workshop equipment required

- ◆ Release tool for radio/navigation - T10057-

Description of the function ⇒ Owner's manual Yeti .

#### Removing

The CD changer is located in the luggage compartment in the left side trim panel.

- Remove all the CDs out of the CD changer ⇒ Owner's manual Yeti .
- Switch off radio/navigation, ignition and all electrical consumers.
- Insert release tool for radio into the holes until it audibly clicks into place, see fig.
- Remove the CD changer from the bracket by pulling on the release tool -arrows-.
- Disconnect plug.
- Press together the lateral retaining tabs on the CD changer and take the release tool for radio/navigation - T10057- out of the CD changer.

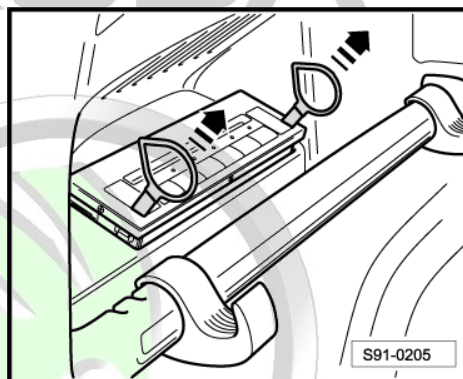

#### Install

- Mount plug.
- Insert the CD changer in the bracket until it clicks audibly into place.

### 8.2 Plug connection on the CD changer

#### Contact assignment of the 12-pin plug connection

- 1 - Data CD out (in radio)
- 2 - CD-CLK out (in radio)
- 3 - CD earth
- 4 - Data CD in (out radio)
- 5 - not assigned
- 6 - 12 V power supply (from radio)
- 7 - right channel +
- 8 - switched positive (from radio)
- 9 - Signal ground
- 10 - left channel +
- 11 - not assigned
- 12 - not assigned

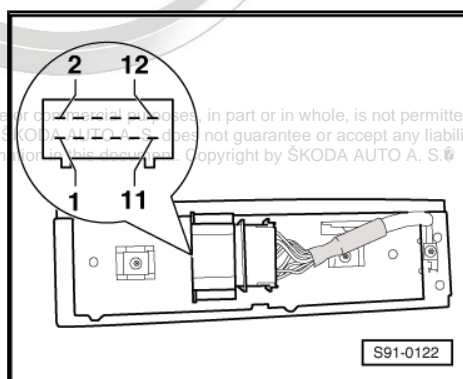

Protected by copyright. Copying for private or commercial purposes, in part or in whole, is not permitted unless authorised by ŠKODA AUTO A. S. ŠKODA AUTO A. S. does not guarantee or accept any liability with respect to the correctness of information published here. Copyright by ŠKODA AUTO A. S. ©

## 9 Connection for external audio sources - R199-

⇒ [“9.1 General description”, page 71](#)

⇒ [“9.2 Removing and installing the connection for external audio sources R199”, page 71](#)

### 9.1 General description

This is designed to connect the audio signal from the external stereo systems and to play back music from these systems via the radio/navigation installed ex works.

As of CW 45.2014, the USB connection is installed as well as the connection for external audio sources.

Description of function and additional information ⇒ Operating instruction of the radio/navigation system .

Contact assignment of plug connection and current flow diagram ⇒ Current flow diagrams, Electrical fault finding and Fitting locations.

### 9.2 Removing and installing the connection for external audio sources - R199-

⇒ [“9.2.1 Removing and installing connection for external audio sources R199 \(AUX\) under the armrest”, page 71](#)

⇒ [“9.2.2 Removing and installing the connection for external audio sources R199 \(AUX, USB\) under the heating and air conditioning control”, page 72](#)

#### 9.2.1 Removing and installing connection for external audio sources - R199- (AUX) under the armrest

##### Removing

- Switch off the radio/navigation, all electrical consumers and take out the ignition key.
- Remove the centre console between driver and front passenger ⇒ Body Work; Rep. gr. 68 .
- Disconnect plug.
- Press together the retaining tabs -arrows- and push connection for external audio sources -1- out of the centre console -2-.

##### Install

Installation is carried out in the reverse order.

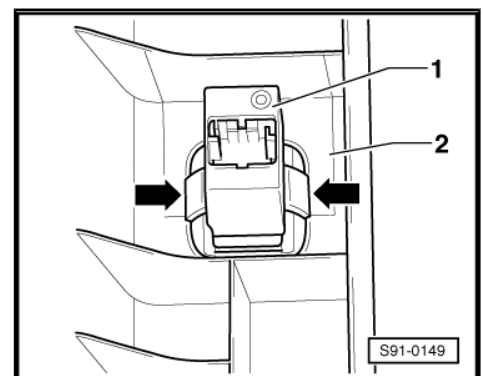

## 9.2.2 Removing and installing the connection for external audio sources - R199- (AUX, USB) under the heating and air conditioning control

### Removing

- Switch off the radio/navigation, all electrical consumers and take out the ignition key.
- Place removal wedges under trim -1- in region of arrows -A- one after the other.
- Unclip trim with connections -1- and slide out in direction of arrows -B-, taking account of the lengths of the connected cables.

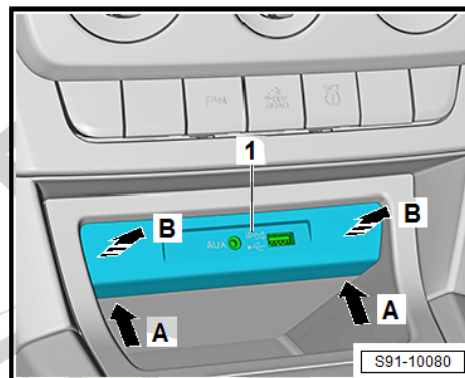

- Unlock and pull off plugs -1- and -2-.
- If necessary, unclip the connection for external audio sources -4- and the USB connection -3- -arrows- and take off the trim -5-.

### Install

Installation is carried out in the reverse order.

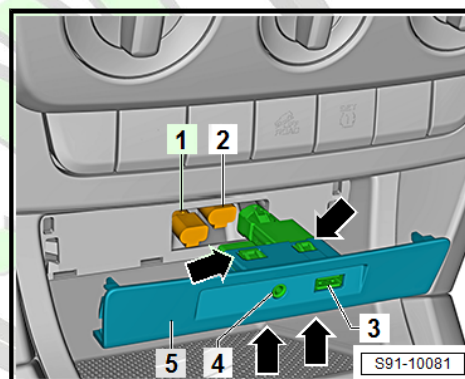

Protected by copyright. Copying for private or commercial purposes, in part or in whole, is not permitted unless authorised by ŠKODA AUTO A. S. ŠKODA AUTO A. S. does not guarantee or accept any liability with respect to the correctness of information in this document. Copyright by ŠKODA AUTO A. S. ©



## 10 Multimedia socket MEDIA-IN (MDI) with control unit for multimedia system - J650-

⇒ ["10.1 General description", page 73](#)

⇒ ["10.2 Removing and installing multimedia socket", page 73](#)

⇒ ["10.3 Removing and installing the control unit for multimedia system J650", page 73](#)

### 10.1 General description

Installed up to CW 44.2014, then replaced by connection for external audio sources, USB connection.

This is designed to connect the audio signal from the external stereo systems and to play back music from these systems via the radio/navigation installed ex works.

Contact assignment of plug connection and current flow diagram  
 ⇒ Current flow diagrams, Electrical fault finding and Fitting locations.

Further information and description of function:

- ◆ ⇒ Operating instruction of the radio/navigation system
- ◆ ⇒ Self-study programme No. 72 ; Škoda Yeti, introduction of the vehicle

### 10.2 Removing and installing multimedia socket

The multimedia socket MEDIA-IN is located under the heating/air conditioning control.

#### Removing

- Remove storage compartment in the front centre console ⇒ Body Work; Rep. gr. 68 .
- Unscrew the fuse in direction of arrow -A-, press the catch peg in the direction of arrow -B- and remove the socket from the storage compartment in the direction of the arrow -C-.
- Remove heating control if necessary air conditioning system control ⇒ Heating, Air Conditioning; Rep. gr. 80 or ⇒ Rep. gr. 87 .
- Disconnect the plug from the control unit for multimedia system - J650- which is fitted behind the heating/air conditioning system control and remove the power socket with the cable.

#### Install

Installation is carried out in the reverse order.

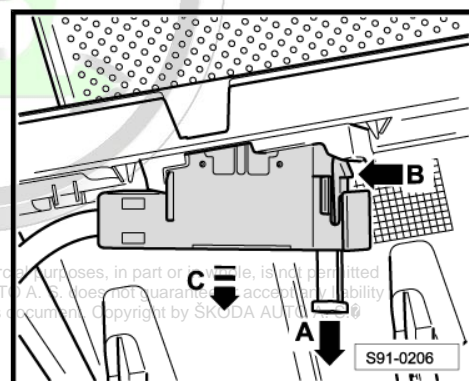

### 10.3 Removing and installing the control unit for multimedia system - J650-

Installed up to CW 44.2014 (depending on equipment).

The control unit for multimedia system - J650- is located behind the heating/air conditioning system control.

#### Removing

- Remove heating control if necessary air conditioning system control ⇒ Heating, Air Conditioning; Rep. gr. 80 or ⇒ Rep. gr. 87 .



- Release the control unit -2- from the bracket by sliding it to the left -arrow-.
- Disconnect the plugs -1- and -3- and take out the control unit.

**Install**

Installation is performed in the reverse order, pay attention to the following points:

- When replacing, code the new control unit after the installation with the ➔ Vehicle diagnostic tester.

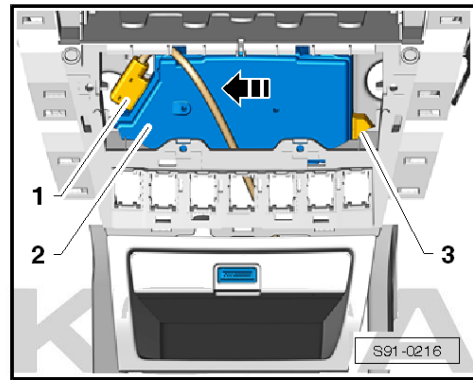

Protected by copyright. Copying for private or commercial purposes, in part or in whole, is not permitted unless authorised by ŠKODA AUTO A. S. ŠKODA AUTO A. S. does not guarantee or accept any liability with respect to the correctness of information in this document. Copyright by ŠKODA AUTO A. S. ©

## 11 SmartLink system

⇒ **“11.1 General points”, page 75**

### 11.1 General points

- ◆ The SmartLink system handles the communication between the vehicle's infotainment system and a connected communication device (mobile phone/tablet) belonging to the customer.
- ◆ Using this system, the software applications installed in the communications equipment (such as navigation, web radio, weather), can be displayed and controlled in the infotainment display.
- ◆ The SmartLink system is part of the maximum infotainment equipment (Bolero, Amundsen) and has no other separately installed parts.
- ◆ For a detailed description of the functions, operations and connection, see the ⇒ Operating instructions of the Bolero/ Amundsen infotainment system .

The SmartLink function supports the following types of connection

- ◆ Android Auto
- ◆ Apple CarPlay
- ◆ MirrorLink



#### Caution

*For correct communication with the SmartLink system, the customer's communications device (mobile phone/tablet) and the installed software applications must function correctly.*

*Not every mobile phone/tablet is compatible with the SmartLink system.*

*For details of mobile phone/tablet compatibility, and the available applications, visit the ŠKODA website.*

*ŠKODA AUTO a.s. assumes no responsibility for any problems due to incompatibility or improper function of cell phones/tablets or the applications installed on them*



## 12 SmartGate system

⇒ ["12.1 General points", page 76](#)

⇒ ["12.2 SmartGate system - check the correct function", page 77](#)

⇒ ["12.3 Remove and install control unit for information electronics 2 J829 \(SmartGate\)", page 78](#)

⇒ ["12.4 Set the parameters for the Wi-Fi connection", page 79](#)

⇒ ["12.5 Update firmware", page 80](#)

### 12.1 General points

#### SmartGate system

- ◆ The SmartGate system offers the possibility to access the driving data via the wireless Wi-Fi connection.
- ◆ This is one-way communication of the connected communications of the customer's equipment (e.g., cell phone, tablet, laptop) with the control unit for the SmartGate system.
- ◆ The driving data received can then be processed (depending on the application used and installed on the communications equipment).
- ◆ The Wi-Fi range is limited to the interior of the vehicle.
- ◆ One part of the system is the control unit for information electronics 2 - J829- located under the driver's seat.
- ◆ For a detailed description of the functions, operations and connection see the ⇒ Owner's manual Yeti .



#### Caution

*Correct communication within the scope of the SmartGate system relies on the customer's communications equipment (e.g., cell phone/tablet) functioning correctly, and on the software applications being installed.*

*Not every cell phone/tablet is compatible within the scope of the SmartGate system.*

*For details of mobile phone/tablet compatibility, and the available applications, visit the ŠKODA website ([www.skoda-auto.com](http://www.skoda-auto.com)).*

*ŠKODA AUTO a.s. assumes no responsibility for any problems due to incompatibility or improper function of cell phones/tablets or the applications installed on them*

Protected by copyright. Copying for private or commercial purposes, in part or in whole is not permitted without the prior written consent of ŠKODA AUTO A. S. ŠKODA AUTO A. S. does not accept any liability for the content of this document.

## 12.2 SmartGate system - check the correct function



### Caution

*Correct communication within the scope of the SmartGate system relies on the customer's communications equipment (e.g., cell phone/tablet) functioning correctly, and on the software applications being installed.*

*Not every cell phone/tablet is compatible within the scope of the SmartGate system.*

*For details of mobile phone/tablet compatibility, and the available applications, visit the ŠKODA website ([www.skoda-auto.com](http://www.skoda-auto.com)).*

*ŠKODA AUTO a.s. assumes no responsibility for any problems due to incompatibility or improper function of cell phones/tablets or the applications installed on them*

For a detailed description of the functions, operations and connection see the ⇒ Owner's manual Yeti .

The correct function of the SmartGate system is verified by the device itself.

To check it is working correctly, you can use e.g. ⇒ Vehicle diagnostic tester, mobile phones, tablets, and laptops, referred to as communication devices below.

For the connection, ask the customer for the PIN code (password) for the SmartGate system.

### Connecting with a Wi-Fi device

Preconditions:

- ◆ Switch on Wi-Fi on the connected communications equipment
- ◆ Switch on the ignition

### Open a connection to SmartGate (login to a Wi-Fi network)

- ◆ Search for available Wi-Fi connections on the connected communications equipment – SmartGate identifies the connected communications device as SmartGate\_...  
Information for legal purposes, in part or in whole, is not permitted to be reproduced by ŠKODA AUTO A. S. ŠKODA AUTO A. S. does not guarantee or accept any liability with respect to the correctness of information in this document. Copyright by ŠKODA AUTO A. S. ©
- ◆ The last six symbols of the vehicle identification number (VIN code) are displayed at the position....
- ◆ Enter the password supplied by the customer, for the initial connection, enter the 17 digits of the vehicle identification number (VIN) (in uppercase).



### Note

- ◆ *If no PIN code (password) is available, then switch off the ignition and, if necessary, disconnect the battery earth strap or the connector on the SmartGate unit for approx. 30 seconds.*
- ◆ *After re-connecting the battery earth strap, switch on the ignition and enter the vehicle identification number (in uppercase) as the PIN code.*
- ◆ *Up to four communications devices can be connected to the SmartGate system at the same time.*



## Connection problems

If the connection fails, then check the following points:

- ◆ Are the conditions for a successful connection fulfilled?
- ◆ Does SmartGate show up in the list of available Wi-Fi networks?
- ◆ Was password required for validating the connection entered correctly?
- ◆ Is the communications equipment to be connected possibly still connected to another Wi-Fi network?

**If the above points are okay, and the connection still fails, then check the state of the LED display on the control unit for information electronics 2 - J829- (SmartGate) located under the driver's seat.**

**If the LED display -arrow- on the control unit:**

- ◆ is unlit or lit red, the device is not OK, check the electrical wiring as per ⇒ Current flow diagrams, Electrical fault finding and Fitting locations; if needed, replace the SmartGate control unit
- ◆ red flashing - this is a self-test, wait for the test to complete (on initial activation)
- ◆ lit green – the device is OK, no user is connected
- ◆ green flashing - the device is OK, at least one user is connected and the SmartGate application is active on the connected communication device (if you connect without an active application - the LED display is lit green)
- ◆ flashing red and green - the device is OK; and still in production mode (indicates production mode, for example in Production, where multiple vehicles with SmartGate exist at one location)
- ◆ orange (red and green at the same time) – the device is in upgrade mode, wait for this mode to complete

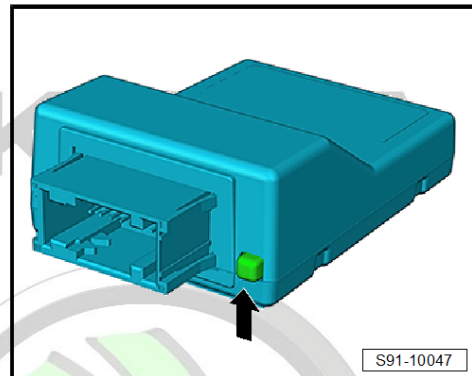

## Disconnecting

The connection to SmartGate can be disconnected in one of the following ways:

- ◆ by disconnecting the connection to SmartGate on the connected communications device
- ◆ by disabling Wi-Fi on the connected communications device
- ◆ by switching off the ignition and removing the ignition key for more than 5 s (for vehicles with an ignition starter switch, by switching off the ignition and opening the driver door)

## 12.3 Remove and install control unit for information electronics 2 - J829- (SmartGate)

### Removing

The control unit for information electronics 2 - J829- (SmartGate) is fastened under the driver's seat on the floor covering by means of a Velcro fastener.

- Move the driver's seat as far back and up as possible.

- Remove control unit -1- from the Velcro fastener and, taking the lengths of the connected cables into consideration, remove the unit.
- Unplug connector -2-.

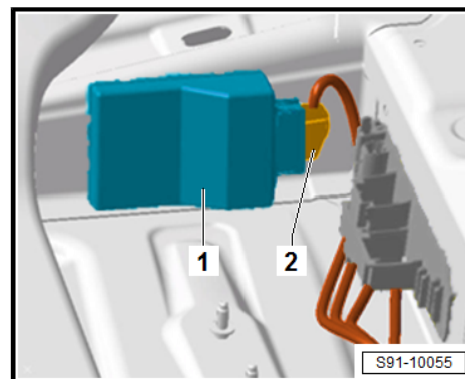

- To pull off the connector, press the latch -1-, and release the connector by tilting out the bar -arrow-.

### Install

Installation is performed in the reverse order, pay attention to the following points:

- Installation position of the control unit, see figure.
- Do the following when replacing the control unit:
  - ◆ Update firmware ⇒ ["12.5 Update firmware", page 80](#)
  - ◆ Check functionality ⇒ ["12.2 SmartGate system - check the correct function", page 77](#)

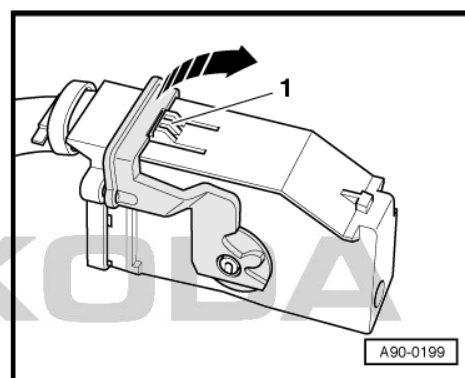

## 12.4 Set the parameters for the Wi-Fi connection

Some properties of the Wi-Fi connection can be changed and configured using the connected communications device (e.g., ⇒ Vehicle diagnostic tester, cell phone, tablet, laptop).

After fulfilling the conditions for a successful connection, enter the address "HTTP://192.168.123.1/index.html" in the web browser of the connected communications device. You will see a menu for setting the parameters for the SmartGate Wi-Fi connection.

Configuration options:

- ◆ SSID
- ◆ Chanel (1 to 10) – manual setting of the connection channel
- ◆ Security – setting the security level for the connection

Open – unencrypted connection, no password entry required on the device to be connected; the connection is set up automatically

WPA or WPA2 – encrypted connection

- ◆ WPA/WPA2 key - password input
- ◆ Transmitting power in % - sets the signal strength in percent
- ◆ DHCP (lease time) - time for which the IP address remains valid
- ◆ Web interface: Port - web interface

If you change the connection encryption from unsecured (open) to secured WPA or WPA2, you must enter a password on the communications equipment to be connected.

If no PIN code (password) is available, then switch off the ignition and, if necessary, disconnect the battery earth strap or the connector on the SmartGate unit for approx. 30 seconds. The Smart-



Gate is reset to the factory default settings and transmission encryption is set to WPA2.

After re-connecting the battery earth strap, switch on the ignition and enter the vehicle identification number (in uppercase) as the PIN code.

## 12.5 Update firmware

To update the SmartGate firmware, you can use, e.g., ⇒ Vehicle diagnostic tester cell phones, tablets, laptops, mobile phones; referred to as communications devices in the following.



### Caution

***Correct communication within the scope of the SmartGate system relies on the communications device functioning correctly, and on the software applications being installed.***

***Not every cell phone/tablet is compatible within the scope of the SmartGate system.***

***For details of mobile phone/tablet compatibility, and the available applications, visit the ŠKODA website (www.skoda-auto.com).***

***The firmware update function is not available in the Internet Explorer web browser version 9 and older.***

Update data from the ŠKODA website are needed for the firmware update.

During the entire upgrade process, make sure that the ignition is on, or the engine is running (avoid starting the engine during the upgrade procedure).

### Update procedure:

- Download the update data for SmartGate from the ŠKODA website; save them on the communications device (one file).
- Switch on Wi-Fi on the communications device.
- Switch on the ignition and start the engine.
- Connect the communications device with SmartGate.
- Open the web browser on the communications device, and enter the address "HTTP://192.168.123.1/index.html".
- At the bottom of the SmartGate menu that appears, select the firmware upgrade menu item.
- Select the update data stored on the communications device.
- Pressing "start update" copies the update data to SmartGate (copying takes about 5 min).
- After downloading the data and confirming "perform update", the update starts (the update process takes approx. 2 min).
- After completing firmware update, the SmartGate is restarted.

for commercial purposes, in part or in whole, is not permitted unless authorised by ŠKODA AUTO A. S. ŠKODA AUTO A. S. does not guarantee or accept any liability with respect to the correctness of information in this document. Copyright by ŠKODA AUTO A. S.



#### Note

- ◆ *During the update process, the LED display on the control unit for information electronics 2 --J829-- lights up orange (red and green at the same time).*
- ◆ *After completing the update and restarting the SmartGate, the LED display lights up/flashes green, see => [page 78](#) .*

# ŠKODA





## 13 Mobile services online, ERA Glonass system

⇒ [“13.1 General information, ERA Glonass system”, page 82](#)

⇒ [“13.2 Installation location overview, ERA Glonass”, page 82](#)

⇒ [“13.3 Removing and installing control unit for emergency call module and communication unit J949”, page 83](#)

⇒ [“13.4 Removing and installing emergency call button E276”, page 84](#)

⇒ [“13.5 Removing and installing power speaker for emergency call module R335”, page 84](#)

⇒ [“13.6 Replacing battery for control unit for emergency call module and communication unit J949”, page 85](#)

⇒ [“13.7 Replacing and adapting control unit for emergency call module and communication unit J949, vehicles for Russia, Belarus and Kazakhstan”, page 85](#)

⇒ [“13.8 Checking that the components and communication of the ERA Glonass system are functioning”, page 87](#)

### 13.1 General information, ERA Glonass system

ERA Glonass system - applies to vehicles for Russia, Belarus and Kazakhstan.

The functions for mobile services online are integrated into the control unit for emergency call module and communication unit - J949- .

When handling a fault it is absolutely essential to know the functions of the mobile services online.

Further information and description of function ⇒ Owner's Manual Yeti .

Fault finding is performed using ⇒ Vehicle diagnostic tester.

### 13.2 Installation location overview, ERA Glonass



**1 - Control unit for emergency call module and communication unit - J949-**

- ❑ Removing and installing  
 ⇒ [“13.3 Removing and installing control unit for emergency call module and communication unit J949”, page 83](#)

**2 - Speaker for emergency call module - R335-**

- ❑ Removing and installing  
 ⇒ [“13.5 Removing and installing power speaker for emergency call module R335”, page 84](#)

**3 - Telephone microphone - R38-**

- ❑ in the front interior light
- ❑ Removing and installing  
 ⇒ [“3.4 Removing and installing the microphone for the telephone R38”, page 51](#)

**4 - Emergency call button - E276-**

- ❑ Removing and installing  
 ⇒ [“13.4 Removing and installing emergency call button E276”, page 84](#)

**5 - Roof aerial**

- ❑ Removing and installing  
 ⇒ [“4.3 Roof aerial for radio, telephone and navigation system”, page 56](#)

**6 - Radio/navigation system**

- ❑ installed in the dash panel
- ❑ removing and installing ⇒ [“1.4 Removing and installing a radio”, page 40](#) or [“2.5 Removing and installing the navigation system”, page 47](#).

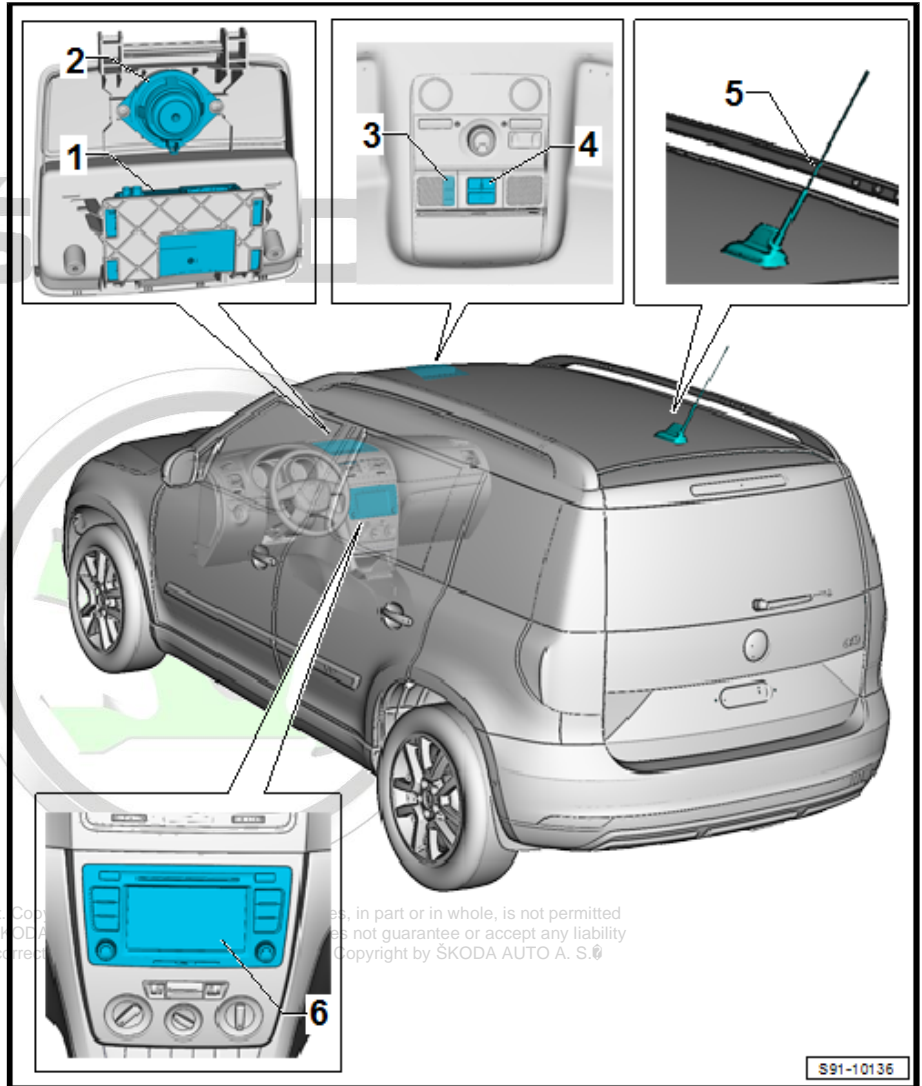

**13.3 Removing and installing control unit for emergency call module and communication unit - J949-**



Note

For replacement, follow  
 ⇒ [“13.7 Replacing and adapting control unit for emergency call module and communication unit J949, vehicles for Russia, Belarus and Kazakhstan”, page 85](#).

**Removing**

- Switch off the ignition and all electrical components.



- Place the ignition key outside the vehicle to avoid accidentally turning on the ignition.
- Remove the storage compartment in the dash panel and carefully pull it out, taking account of the lengths of connected cables ⇒ Body Work; Rep. gr. 70 .
- Unlock and disconnect plug for control unit for emergency call module and communication unit - J949- -1-.
- Push the retaining tabs on the control unit for emergency call module and communication unit - J949- -1- in direction of arrow -A- and, at the same time, pull it in direction of arrow -B- out of the storage compartment -2-.

**Install**

Installation is carried out in the reverse order.

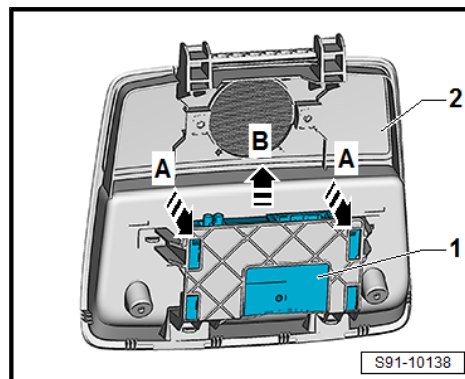

**13.4 Removing and installing emergency call button - E276-**

**Removing**

- Remove front interior light ⇒ ["1.1 Removing and installing the front interior light", page 187](#) .
- Disconnect plug from the emergency call button - E276- Pos. -1-.
- Release the retaining tabs arrows -A- and remove the emergency call button - E276- in direction of arrow -B-.

**Install**

Installation is carried out in the reverse order.

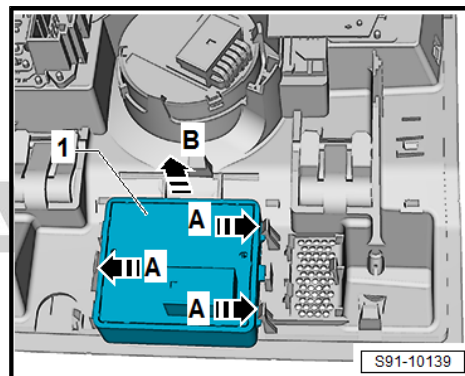

**13.5 Removing and installing power speaker for emergency call module - R335-**

**Removing**

- Remove the storage compartment in the dash panel and carefully pull it out, taking account of the lengths of connected cables ⇒ Body Work; Rep. gr. 70 .
- Disconnect plug from speaker.

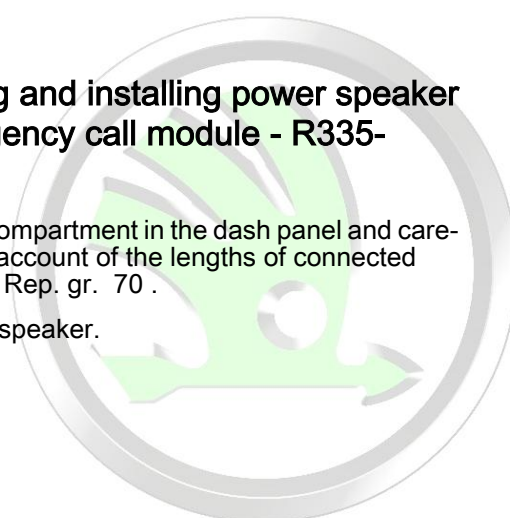



- Unscrew screws -2- and remove the speaker for emergency call module - R335- -1-.

#### Install

Installation is carried out in the reverse order.

#### Tightening torques

Fixing screws for speakers	1.5 Nm
----------------------------	--------

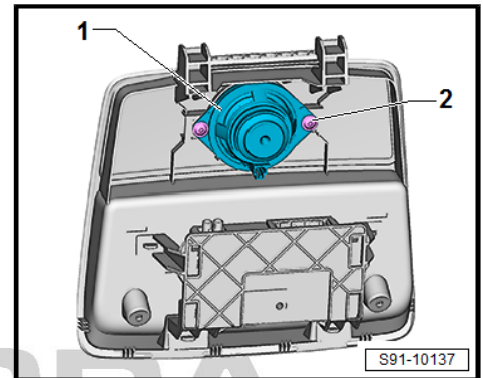

### 13.6 Replacing battery for control unit for emergency call module and communication unit - J949-

- Remove the control unit for emergency call module and communication unit - J949- .  
 ⇒ ["13.3 Removing and installing control unit for emergency call module and communication unit J949", page 83](#)
- Unscrew the screw on the control unit from below and remove the battery cover.
- Replace the battery and re-install the control unit.

### 13.7 Replacing and adapting control unit for emergency call module and communication unit - J949- , vehicles for Russia, Belarus and Kazakhstan

- Data for "targeted fault-finding" in ⇒ Vehicle diagnostic tester current

#### Procedure when replacing:

- In **Targeted fault finding** or **Targeted functions** operating mode for the control unit for emergency call module and communication unit - J949- , select the **Transfer/re-place** function (address 0075) ⇒ Vehicle diagnostic tester.
- Follow the instructions on the ⇒ Vehicle diagnostic tester (includes the steps: coding, parameterisation, adaptation).
- In **Targeted fault finding** or **Targeted functions** operating mode for the control unit for emergency call module and communication unit - J949- , select the **Activate** function ⇒ Vehicle diagnostic tester.
- Exit **Targeted fault-finding** or **Targeted functions**.
- Switch off ignition.
- Switch on ignition.
- Check colour of ERA Glonass system status LED.

Protected by copyright. Copying for private or commercial purposes, in part or in whole, is not permitted unless expressly permitted by SKODA AUTO A. S. SKODA AUTO A. S. does not guarantee or accept any liability for the accuracy of the information in this document. Copyright by SKODA AUTO A. S. ©



The status LED -3- is lit red after ignition is switched on. The LED changes from red to green approx. 5 seconds after switching on the ignition (at the latest, within 2 minutes).

If the status LED -2- is green, the ERA Glonass system is activated.



### Caution

*After activating with ⇒ Vehicle diagnostic tester, follow the "Identification" test procedure of the control unit for emergency call module and communication unit - J949- , which will generate an ICC-ID number. You must record this number on the customer order. The customer should then be informed that he/she must notify the road traffic authority that the control unit for emergency call module and communication unit - J949- has been replaced and provide the authority with the above ICC-ID number to be entered in the vehicle database.*

If the status LED is still red even after 2 minutes since ignition was switched on:

Connect ⇒ Vehicle diagnostic tester and then:

- ◆ Read out the signal strength of the GSM and GPS network using ⇒ Vehicle diagnostic tester (address 0075 - read measured values - Network Connectivity)
- ◆ Check that the components and communication are functioning and query the event memory  
⇒ ["13.8 Checking that the components and communication of the ERA Glonass system are functioning", page 87](#)

**If reception is too weak or there is no reception:**

- Change vehicle location (e.g. go to open area with undisrupted reception).

**In the event of an error:**

- Repair/replace the defective system component.

**After changing the vehicle location or after repair is complete:**

- Switch off ignition, wait approx. 2 minutes and then switch on ignition again.
- Check colour of the status LED again.
- The status LED of the ERA Glonass system must be green at the latest within approx. 15 minutes after ignition is switched on.

**If the status LED of the ERA Glonass system is still red even after approx. 15 minutes since the ignition was switched on:**

- Create a DISS ticket (a technical repair request, DISS message) and send it to the Technical Service Centre (TSC).

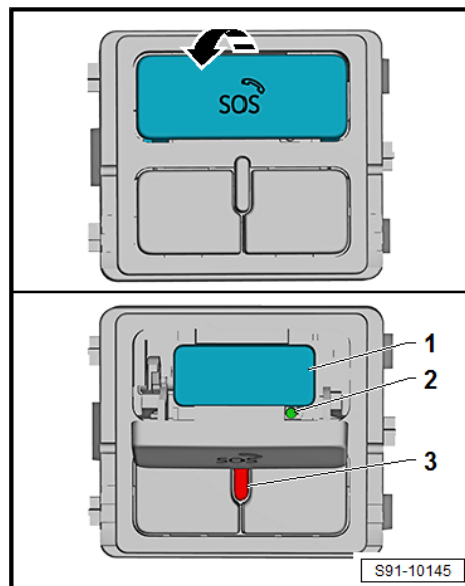

## 13.8 Checking that the components and communication of the ERA Glonass system are functioning

### Note

- ◆ Applies to vehicles for Russia, Belarus and Kazakhstan.
- ◆ You can check that the individual components are working and the ERA Glonass system is communicating with the → Vehicle diagnostic tester or by performing the system self-test.
- ◆ To run the function test for the components and communication, the ERA Glonass system must be activated.
- ◆ The ERA Glonass system is activated for the first time after switching off transport mode (see → Maintenance ; Booklet Yeti ).

The self-test checks the following:

- ◆ OCU unit, SW integrity and realtime
- ◆ GNSS (GPS) aerial
- ◆ GSM aerial
- ◆ Microphone
- ◆ Loudspeaker
- ◆ Connection of the unit with other components (BUS communication, airbag)
- ◆ Connection of HMI components
- ◆ Button in headliner
- ◆ Condition of the emergency battery

### Self-test of the components and communication of the ERA Glonass system

- Switch on ignition.
- Swivel out the cap cover for the SOS button -arrow- and press the button -2- for approx. 3 seconds with a thin tool (e.g. a pin).

- 1 - Emergency call button
- 2 - LED warning light
- 3 - Test start button

- Pressing the button -2- activates the voice prompts for the test sequence. The individual steps are confirmed by pressing the button -1-.

- Also follow the voice prompts.

A voice prompt confirms if the test sequence has been completed successfully.

Evaluate the test before switch off the ignition.

The test result is indicated by the type of flashing signals from the warning light -3-.

- After the ignition is switched off, the ERA Glonass system is reactivated and the warning light lights up green for a short period (the warning light may light up green even if a fault has been identified).

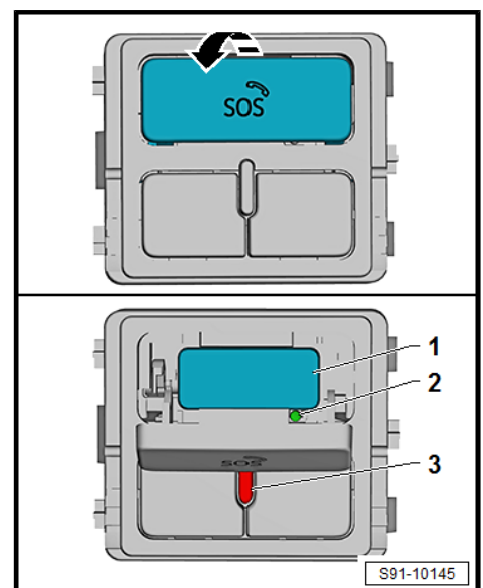

S91-10145

**Evaluating the test:**

Step	Tested component/communication	Determined state	LED warning light flashes
0	ERA Glonass system	No fault detected	green
1	Vehicle identification number	Vehicle identification number empty/ no configuration	x1 green, x1 red
2	Microphone	Microphone not working	x1 green, x2 red
3	Loudspeaker	Speaker not working	x1 green, x3 red
4	Button in headliner	Button not working	x1 green, x4 red
5	Airbag/crash sensors	No signal	x1 green, x5 red
6	Main GSM aerial	No signal	x1 green, x6 red
7	Reserve GSM aerial (if fitted)	No signal	x1 green, x7 red
8	GNSS (GPS) aerial	No signal	x1 green, x8 red
9	Mute signal	Line interruption	x1 green, x9 red
10	IVS internal error	Internal IVS/SIM card/NAD not functioning correctly	x1 green, x10 red
11	Emergency battery (see ⇒ <a href="#">"13.6 Replacing battery for control unit for emergency call module and communication unit J949"</a> , page 85 )	Battery weak/defective	x1 green, x11 red
12	Ignition	Failure/interruption of ignition	x1 green, x12 red

Protected by copyright. Copying for private or official purposes, in part or in whole, is not permitted unless authorised by ŠKODA AUTO A. S. ŠKODA AUTO A. S. does not guarantee or accept any liability with respect to the correctness of information in this document. Copyright by ŠKODA AUTO A. S.

## 92 – Windscreen wash/wipe system

### 1 Windscreen washer system

⇒ [“1.1 Check function”, page 89](#)

⇒ [“1.2 Remove and install reservoir, pumps and sensor for washer fluid level”, page 89](#)

⇒ [“1.3 Removing and installing the spray nozzles for windscreen washer system”, page 90](#)

⇒ [“1.4 Removing and installing the spray nozzle for rear window washer system”, page 91](#)

⇒ [“1.5 Repairing washer fluid lines”, page 92](#)

#### 1.1 Check function

The function of the windscreen washer system can be checked with the ⇒ Vehicle diagnostic tester via the final control diagnosis of the vehicle voltage control unit - J519- .

#### 1.2 Remove and install reservoir, pumps and sensor for washer fluid level

##### Removing



##### Note

◆ Depending on the version, the positions of the individual components and the hose connection can differ from the version in the illustrations. The assembly work can be carried out in a similar way.

◆ For vehicles with auxiliary heating, there is a different arrangement of the pumps and the sensors at the reservoir, however their separation procedure is identical.

- Switch off the ignition and all electrical components.
- Remove front bumper ⇒ Body Work; Rep. gr. 63 .
- Release plug from the washer fluid pumps for windscreen -2-, for headlight -10- and from sensor for washer fluid level -6-.
- To unlock, pull out the locking clip on the hose connections -5- (black marking - front windscreen washer) and -3- (white marking - rear windscreen washer) and disconnect the connections from the washer fluid pump -4-. Collect the flowing out washer fluid in a suitable vessel.
- Release washer hose for headlight -8- by pressing the locking clip and detach.
- If necessary pull the washer fluid pumps -9- and -4- out of the reservoir to the top as well as the sensor for washer fluid level -7- out of the rubber bearing.
- Clear away wiring harness.

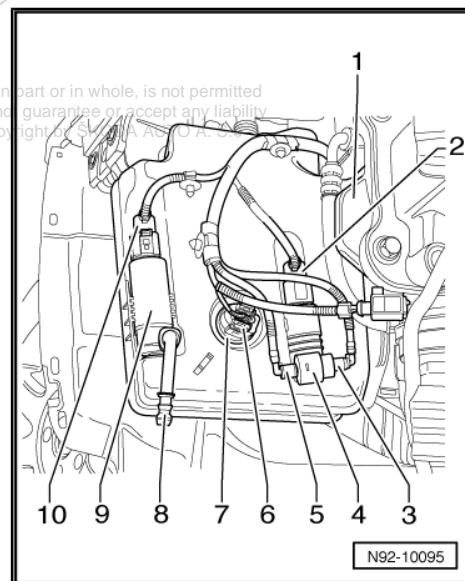



- Loosen pipe -3- for activated charcoal filter system or pipe for auxiliary heating from filler neck -2- of windshield washer reservoir.
- Unscrew bolt -1-.
- Remove headlight ⇒ [page 111](#) .

**Vehicles without auxiliary heating system**

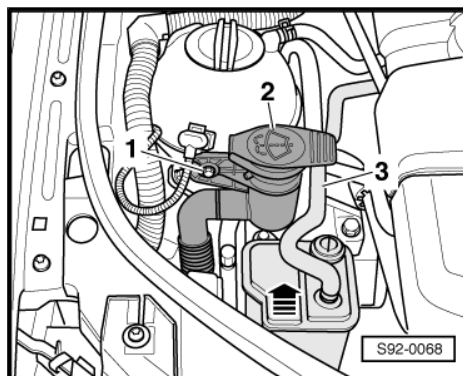

- Unscrew screws and nuts -arrows- and remove washer fluid reservoir downwards.

**Vehicles fitted with auxiliary heating**

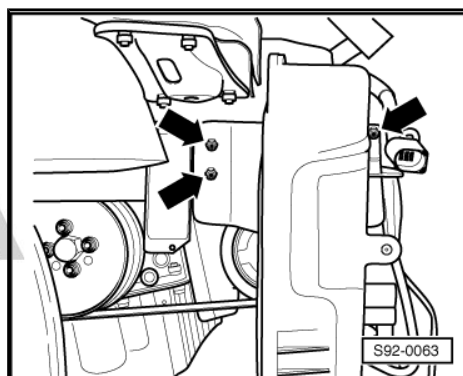

- Unscrew the front fixing screws -arrows from the side- and the rear fixing screw -arrow from the top-.
- Push the reservoir slightly forwards, during this procedure slacken it from the bearing in the bracket and remove it to the bottom.

**Install**

Installation is performed in the reverse order, pay attention to the following points:

- Vehicles fitted with auxiliary heating- observe the correct seating of the guides in the recesses in the holder of the reservoir.
- Hoses with angled pieces must click audibly into the connections on the washer fluid pumps.
- After completing the assembly work bleed the headlamp cleaning system

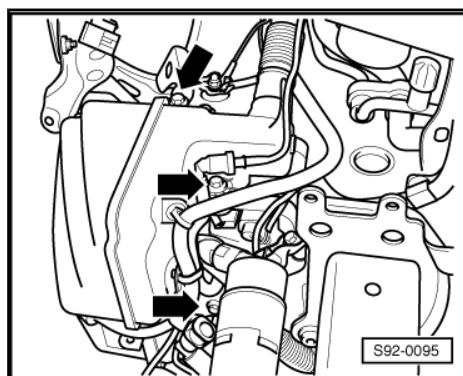

Copyrighted by copyright. Copying for private or commercial purposes, in part or in whole, is not permitted without the prior written consent of ŠKODA AUTO A. S. ŠKODA AUTO A. S. does not guarantee or accept any liability with respect to the correctness of information in this document. Copyright by ŠKODA AUTO A. S. ©

**Tightening torques**

Fixing screw for reservoir support	8 Nm
Fixing screws for reservoir	8 Nm

**1.3 Removing and installing the spray nozzles for windscreen washer system**

**i Note**

*Do not use any objects for cleaning the spray nozzles. It is possible to rinse out the nozzle and then blow through it with compressed air against the direction of the spray.*



## Removing

- Tilt the nozzle out of the front flap -arrow- and remove.

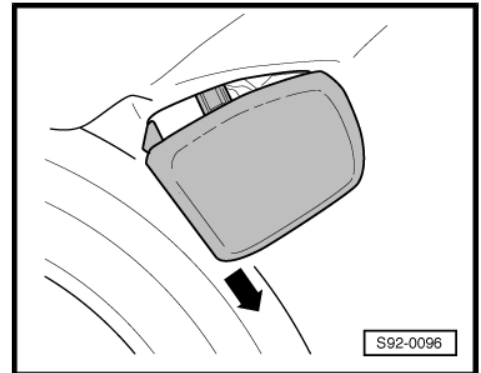

- Unplug the connector from the heated spray nozzle -2-.
- Pull out the locking clip -arrow- and separate hose with angular piece -1-.

## Install

Installation is performed in the reverse order, pay attention to the following points:

- Hoses with angled pieces must click audibly into the connections on the spray nozzles.
- Perform a functional check or adjust nozzles => Maintenance ; Booklet Yeti .

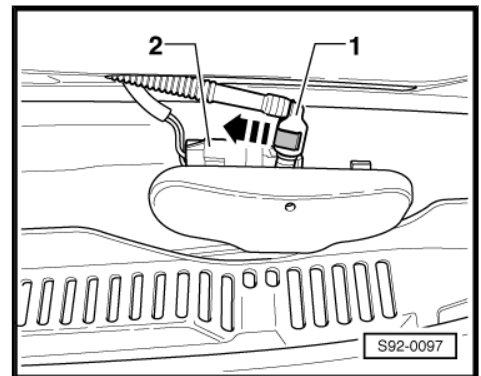

## 1.4 Removing and installing the spray nozzle for rear window washer system

### Removing

- Open cap of rear window wiper.
- Use suitable pliers to carefully pull out spray nozzle in direction of arrow.

### Install

- Run wiper until it is in park position  
 => ["3.1 Removing and installing the windscreen wiper arm and setting its final position", page 105](#) .
- Push spray nozzle fully into the wiper arm shaft so that the opening of the spray nozzle is facing vertically up.
- The spray should strike the rear window as shown in the illustration when the vehicle is stationary. The dimension -B- is 157 mm. The cross shows the fluid point of impact.

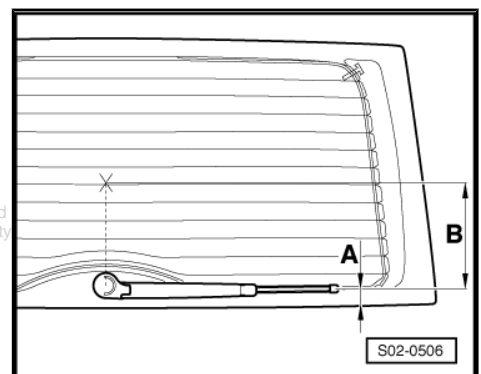
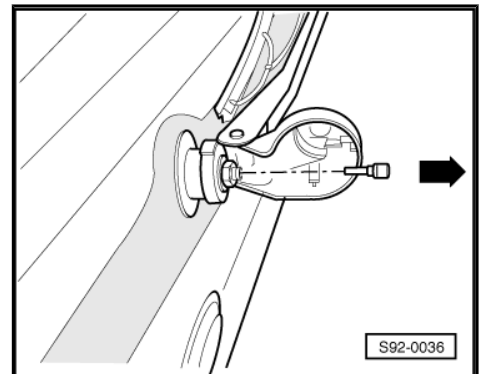

Protected by copyright. Copying for private or commercial purposes, in part or in whole, is not permitted unless authorised by ŠKODA AUTO A. S. ŠKODA AUTO A. S. does not guarantee or accept any liability with respect to the correctness of information in this document. Copyright by ŠKODA AUTO A. S. ©



## 1.5 Repairing washer fluid lines

All the notes and comments to this chapter can be found in the Workshop Manual "Electrical System - General notes" → Electrical System - General notes; Rep. gr. 92 .

# ŠKODA



Protected by copyright. Copying for private or commercial purposes, in part or in whole, is not permitted unless authorised by ŠKODA AUTO A. S. ŠKODA AUTO A. S. does not guarantee or accept any liability with respect to the correctness of information in this document. Copyright by ŠKODA AUTO A. S.®

## 2 Windscreen wiper system

⇒ [“2.1 General description”, page 93](#)

⇒ [“2.2 Removing and installing the wiper arms with wiper blades and setting their final setting”, page 93](#)

⇒ [“2.3 Removing and installing wiper motor with linkage”, page 95](#)

⇒ [“2.4 Removing and installing the wiper motor from the wiper frame”, page 95](#)

⇒ [“2.5 Removing and installing Sensor for rain and light detection”, page 97](#)

### 2.1 General description

#### General description

The wiper motor control unit - J400- and the windscreen wiper motor - V- are installed as one component and cannot be replaced separately.

To remove the wiper blades the wiper arms must be moved into the “service/winter position”. Service / winter position is activated by positioning the windscreen wiper lever within 10 seconds after switching off the ignition in position “flick wipe”. Additional information ⇒ Owner’s manual Yeti .

⇒ [“2.2 Removing and installing the wiper arms with wiper blades and setting their final setting”, page 93](#)

⇒ [“2.3 Removing and installing wiper motor with linkage”, page 95](#)

⇒ [“2.4 Removing and installing the wiper motor from the wiper frame”, page 95](#)

#### Fault recognition and fault display, coding

The vehicle voltage control unit - J519- , which regulates the functions of the windscreen wiper and washer system, is equipped with self-diagnosis which facilitates the fault finding.

Use the ⇒ Vehicle diagnostic tester for troubleshooting and coding of the windscreen wiper and washer system.

### 2.2 Removing and installing the wiper arms with wiper blades and setting their final setting



#### Note

Protected by copyright. Copying for private or commercial purposes, in part or in whole, is not permitted unless authorised by ŠKODA AUTO A. S. ŠKODA AUTO A. S. does not guarantee or accept any liability with respect to the correctness of information in this document. Copyright by ŠKODA AUTO A. S. ®

*If the wiper motor is switched on during work, the front flap must be closed and the ignition must be switched on, otherwise the voltage supply of the wiper motor is interrupted.*

#### Special tools and workshop equipment required

- ◆ Extractor for wiper arms - T10369/1-

#### Removing

- Switch off the ignition and all electrical components.
- Use a screwdriver to lever off the two caps for nuts on the wiper arms.



- Unscrew the nuts -arrows-.

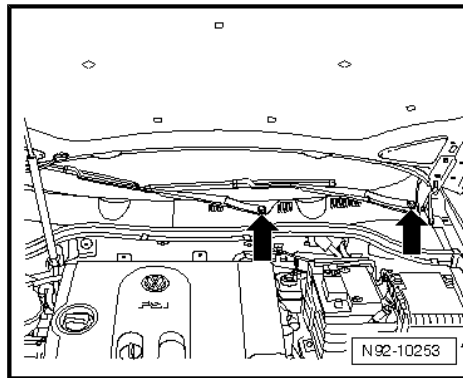

- Push the extractor -2- for wiper arms -T10369/1- , as shown, onto the arm.



**Note**

*To release the wiper arm, always use the thrust piece -3- in order to avoid damage to the thread of the wiper motor shaft.*

- Release the wiper arm -4- from the shaft by turning the pressure screw -1-.

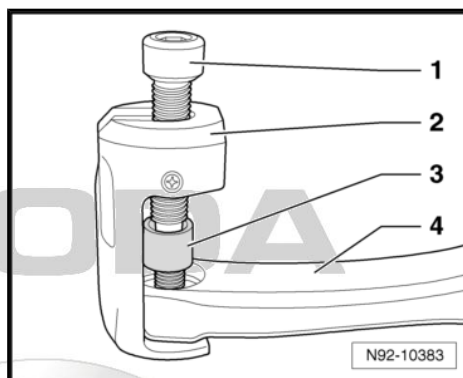

**Install**



**Note**

- ◆ *When switching off for the second time, the wiper motor overruns in the offset final setting so that the wiper blade lip is controlled in the other direction.*
- ◆ *The wiper motor runs downwards and then again a little upwards. This offset final setting cannot be used to compensate for the windscreen wiper arms.*
- ◆ *The final setting must be used in which the wiper motor runs directly and without overrun in the lower final setting. If the wiper motor runs in the offset final setting, wiping must be switched on again.*
- ◆ *The function of the offset final setting (APS function) is only active after 100 wash cycles as of switching off the APS function with ⇒ Vehicle diagnostic tester in the function "targeted fault finding" or after the installation of a new wiper motor. If this function is already activated, it can be determined by switching on and off the wiper motor repeatedly.*

- Switch wiper motor on and off and run until it is in park position for setting the windscreen wiper arms.



- Insert windscreen wiper arms with wiper blades and align wiper blades to the markings in the windscreen -1-.
- Slightly tighten fixing nuts.
- Operate the flick wipe and check again or correct the setting of the wiper arms.
- Tighten securing nuts.

**i** Note

The tolerance between wiper blade and marking -1- is  $\pm 2$  mm.

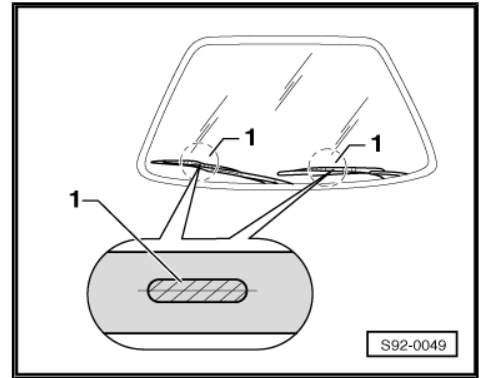

**Tightening torques**

Fixing nut for wiper arms	20 Nm
---------------------------	-------

## 2.3 Removing and installing wiper motor with linkage

**Removing**

- Switch off the ignition and all electrical components.
- Remove wiper arms with wiper blades  
 ⇒ "2.2 Removing and installing the wiper arms with wiper blades and setting their final setting", page 93 .
- Remove the cooling water tank cover ⇒ Body Work; Rep. gr. 66 .
- Separate the plug connection -2- on the wiper motor and place the wiring harness -3- to the side.
- Release screws -1- and -4-.
- Tilt out the wiper motor with the linkage towards you and push it out to the side.

**Install**

Installation is carried out in the reverse order.

**Tightening torques**

Screws, Pos. -1-	10 Nm
Nut, Pos. -4-	5 Nm

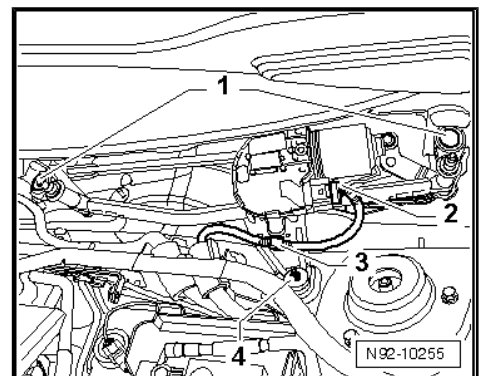

## 2.4 Removing and installing the wiper motor from the wiper frame

**Removing**

- Use a removal tool -MP 8-602/1- to lever off the rod -1- from joint holder -arrow-.

Permission to reproduce this document, for private or commercial purposes, in part or in whole, is not permitted unless authorised by SKODA AUTO A. S. SKODA AUTO A. S. does not guarantee or accept any liability with respect to the correctness of information in this document. Copyright by SKODA AUTO A. S. ©

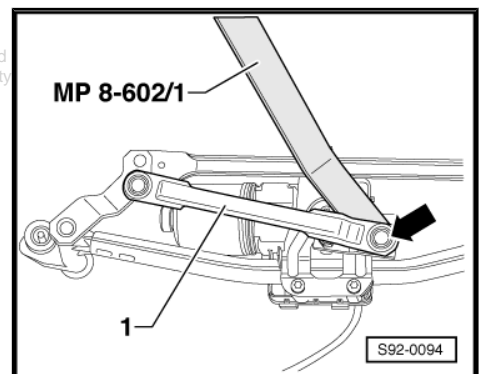



- Release nut -1- and detach engine crank -2- from the wiper motor shaft.
- Unscrew the fixing screws -arrows- and remove the carrier plate -3-.
- Take out the wiper motor with the control unit from the wiper frame.

**Install**



**Note**

- ◆ *If the wiper motor is switched on during work, the front flap must be closed and the ignition must be switched on, otherwise the voltage supply of the wiper motor is interrupted.*
  - ◆ *When switching off for the second time, the wiper motor overruns in the offset final setting so that the wiper blade lip is controlled in the other direction.*
  - ◆ *The wiper motor runs downwards and then again a little upwards. This offset final setting cannot be used for installing the crank of the windscreen wiper motor.*
  - ◆ *The final setting must be used in which the wiper motor runs directly and without overrun in the lower final setting. If the wiper motor runs in the offset final setting, the wiper motor must be switched on again.*
  - ◆ *The function of the offset final setting (APS function) is only active after 100 wash cycles as of switching off the APS function with ⇒ Vehicle diagnostic tester in the function "targeted fault finding" or after the installation of a new wiper motor. If this function is already activated, it can be determined by switching on and off the wiper motor repeatedly.*
- Connect the wiper motor to the plug and run it in the lower final setting by operating the windscreen wiper switch which is used for installing the crank of the windscreen wiper motor.
  - Insert the windscreen wiper motor with the control unit into the wiper frame so that it grips into the recesses -arrows- in the linkage.

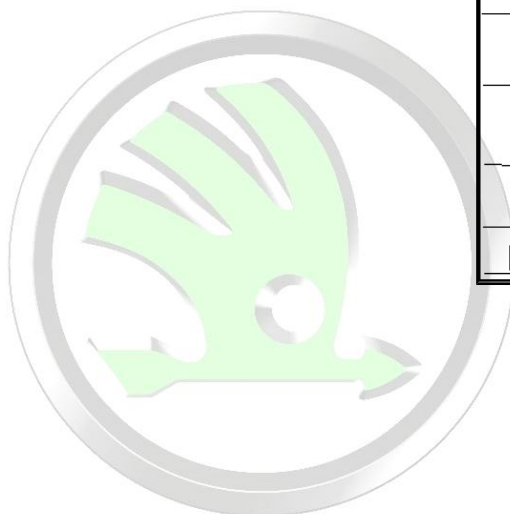
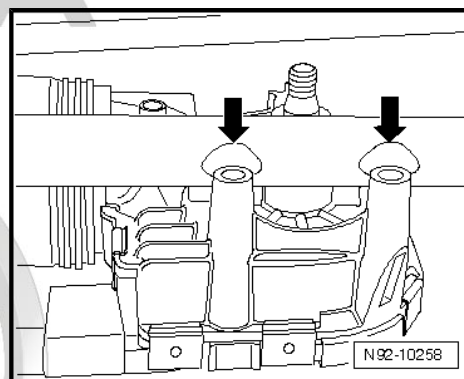
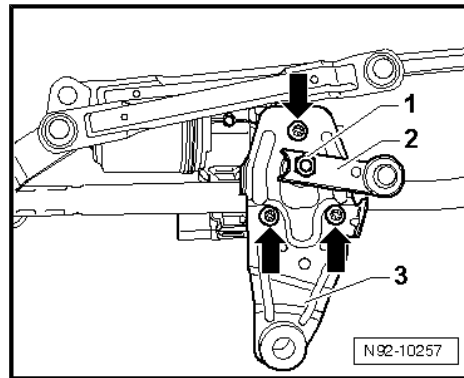



- Insert carrier plate -1- and screw in fixing screws -arrows-.

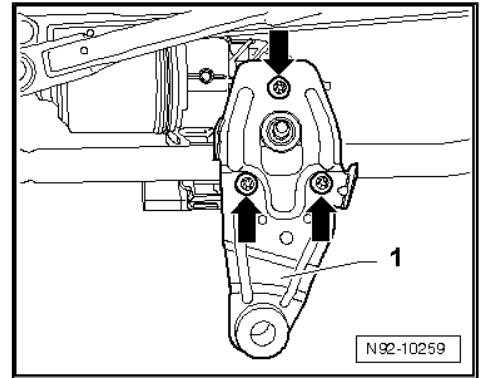

- Position the crank -2- onto the wiper motor shaft until the distance -a- between the edge of the crank -2- and the edge of the carrier plate -3- is 2.7 mm.
- Tighten the nut -1-.

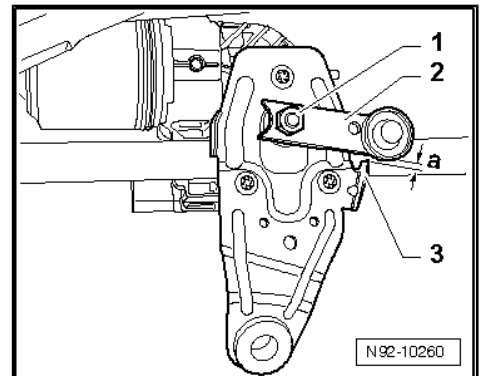

- Press rod -1- onto the joint holder -arrow-.
- Perform a functional test.

**Tightening torques**

Fixing screws for engine carrier plate	10 Nm
Fixing nuts for engine crank	18 Nm

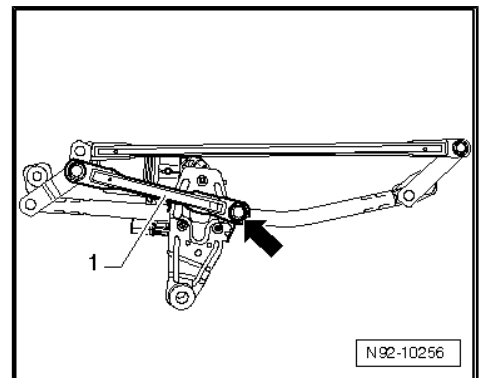

**2.5 Removing and installing Sensor for rain and light detection**

⇒ ["2.5.1 Removing and installing sensor for rain and light detection G397 , vehicles up to CW 45.2015", page 97](#)

⇒ ["2.5.2 Removing and installing sensor for rain and light detection , vehicles from CW 45.2015", page 99](#)

**2.5.1 Removing and installing sensor for rain and light detection - G397- , vehicles up to CW 45.2015**

**Caution**

*If the sensor for rain and light detection - G397- is removed from the retaining plate on the windscreen (e.g. when changing the windscreen), it can be subsequently installed again. Store the removed sensor dust-free until it is installed again and make sure that the silicone coupling cushion does not get dirty.*



### Removing

- Switch off all electrical components and take out the ignition key.
- Removing interior rear-view mirror ⇒ Body Work; Rep. gr. 68 .
- Disconnect plug -1- from sensor -2-.

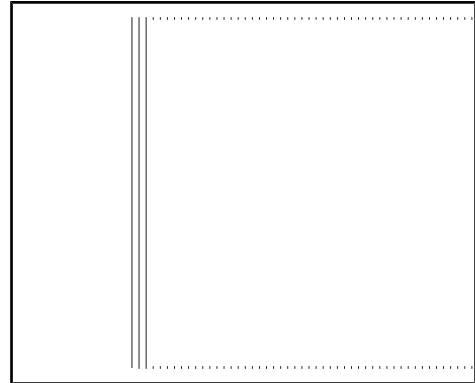

- Lever the sensor -1- carefully and slowly from the retaining plate -2- at the recess -3- using a suitable cross-head screw-driver.



### Note

*When removing, make sure to lever off the complete sensor and not only the upper shell of the sensor.*

### Install

Installation is performed in the reverse order, pay attention to the following points:



### Caution

- ◆ *Thoroughly clean the windscreen inside the retaining plate with e.g. isopropyl (technical alcohol).*
- ◆ *The surface (coupling cushion) of the sensor must not get dirty or damaged when installing. A sensor with a damaged coupling cushion must be replaced.*

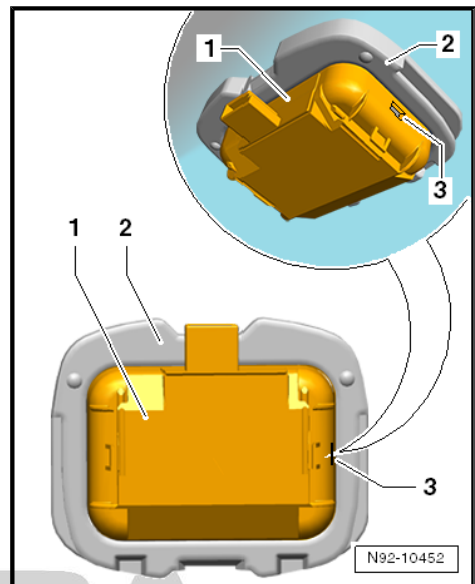

### Note

*If the surface (coupling cushion) of the sensor is dirty, it can be cleaned, if necessary, by sticking on one or several adhesive tapes and then pulling them off again.*

- If necessary, remove the protective cap of the new sensor.

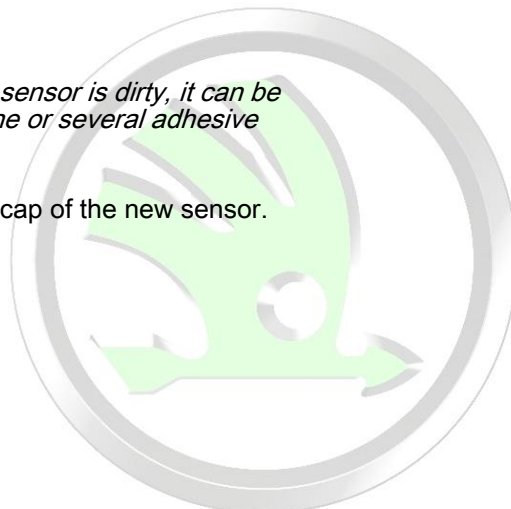



- Insert the sensor -1- into the retaining plate on the windscreen -2- and press firmly.

**i** Note

- ◆ *Even after correct installation of the sensor, smaller air bubbles can be present initially between the windscreen and the coupling cushion. The contact surface must be free of bubbles after approx. 10 minutes.*
- ◆ *When replacing, the new sensor must be coded with the ⇒ Vehicle diagnostic tester.*

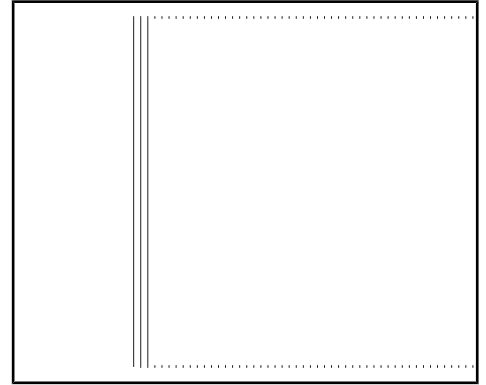

## 2.5.2 Removing and installing sensor for rain and light detection , vehicles from CW 45.2015

Different sensor variants are installed for different versions, depending on equipment (see ⇒ Electronic Catalogue of Original Parts ).

- ◆ Air humidity, rain and light detector sensor - G823-
- ◆ Humidity sender - G355-

### Removing

**i** Note

*To facilitate removal, turn the mirror as necessary.*

- Switch off all electrical components and take out the ignition key.
- Remove sensor covers and interior mirror ⇒ General body repairs; Rep. gr. 68 .
- Disconnect plug connection -3-.
- Release the retaining clips -arrows- with a suitable screwdriver -5-.

**i** Note

*Observe a waiting time of at least 1 minute after releasing the retaining clip. This allows the silicone layer to expand so that it will not be damaged while it is being removed.*

**!** Caution

*If the air humidity, rain and light detection sensor can be removed from the retaining plate on the windscreen (e.g. when changing the windscreen) without damaging the coupling cushion, it can be installed again subsequently. Store the removed sensor dust-free until it is installed again and make sure that the silicone coupling cushion does not get dirty.*

*In most cases, the sensor cannot be removed without damaging the coupling cushion. The coupling cushion must then be replaced before reinstallation.*

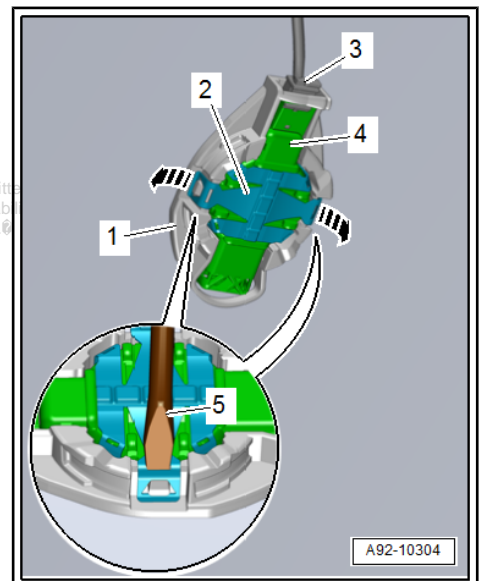



- Carefully lever the humidity, rain and light detection sensor Pos. 2 out of the retaining frame from above starting at the front windscreen.



**Caution**

*Risk of damaging the humidity sender.*

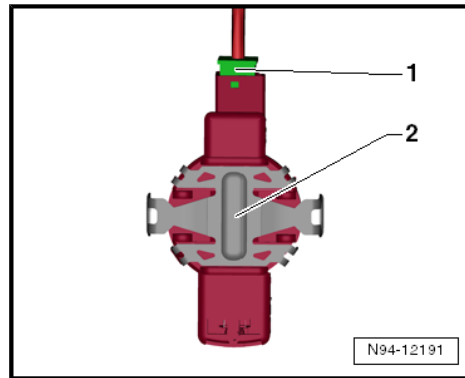

The humidity sender -arrow- is very sensitive and must not be damaged.

If the humidity sender -arrow- is damaged, the entire sender -1- must be replaced.

**Install**

Installation is performed in the reverse order, pay attention to the following points:



**Caution**

- ◆ *Thoroughly clean the windscreen inside the retaining plate with e.g. isopropyl (technical alcohol).*
- ◆ *The surface (coupling cushion) of the sensor must not get dirty or damaged when installing. A sensor with a damaged coupling cushion must be replaced.*
- ◆ *There are several variants of sensors (depending on equipment). Ensure that the correct component is used for replacement, see ⇒ Electronic Catalogue of Original Parts .*

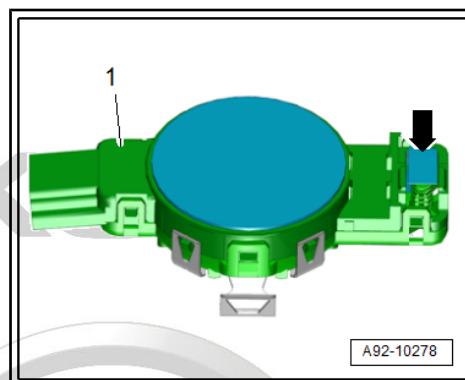

**Note**

*If the surface (coupling cushion) of the sensor is dirty, it can be cleaned, if necessary, by sticking on one or several adhesive tapes and then pulling them off again.*

Protected by copyright. Copying for private or commercial purposes, in part or in whole, is not permitted unless authorised by ŠKODA AUTO A. S. ŠKODA AUTO A. S. does not guarantee or accept any liability with respect to the correctness of information in this document. Copyright by ŠKODA AUTO A. S. ©

- When installing, a new sensor, press the catch pegs in the direction of the arrows -A- and remove cover -1- in direction of arrow -B-.

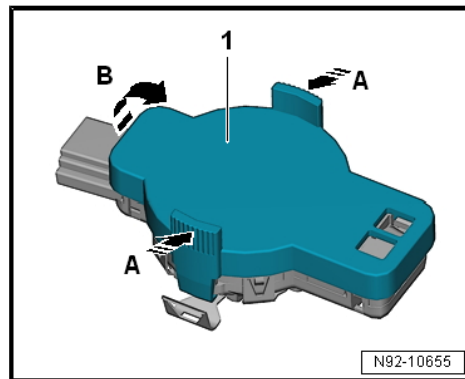



- Press retaining clip -1- on until the catches -arrows- audibly click into place.

**i** Note

- ◆ *Even after correct installation of the sensor, smaller air bubbles can be present initially between the windscreen and the coupling cushion. The contact surface must be free of bubbles after approx. 10 minutes.*
- ◆ *If the contact surface is not free of bubbles after 10 minutes, the sensor must be removed and re-installed.*
- ◆ *Air bubbles between the windscreen and the coupling cushion cause sensor malfunctions.*

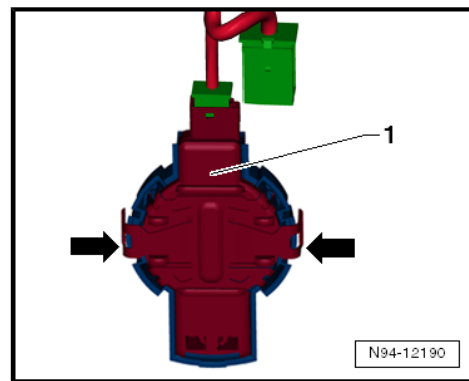

- When replacing, the new sensor must be coded with the ⇒ Vehicle diagnostic tester.

## 2.6 Repairing the humidity, rain and light detection sensor

⇒ [“2.6.1 Repairing the humidity, rain and light detection sensor - made by TRW”, page 101](#)

⇒ [“2.6.2 Repairing the humidity, rain and light detection sensor - made by Valeo”, page 102](#)

### 2.6.1 Repairing the humidity, rain and light detection sensor - made by TRW

**i** Note

*The sensor bushing with optical unit is also supplied with retaining clips as a spare part. These must be removed for vehicles that do not require retaining clips.*

#### Work procedure

- Remove the rain and light detection sensor  
 ⇒ [“2.5.2 Removing and installing sensor for rain and light detection , vehicles from CW 45.2015”, page 99](#) .

**⚠ Caution**

*Risk of damaging the electronics of the sensor for rain and light detection.*

- ◆ *When disconnecting the sleeve parts, do not insert the screwdriver until the electronics of the sensor for rain and light detection.*
- ◆ *Do not touch the electronics of the sensor for rain and light detection.*

- Undo retaining tabs -arrows- with a suitable screwdriver and remove clamps -1-.

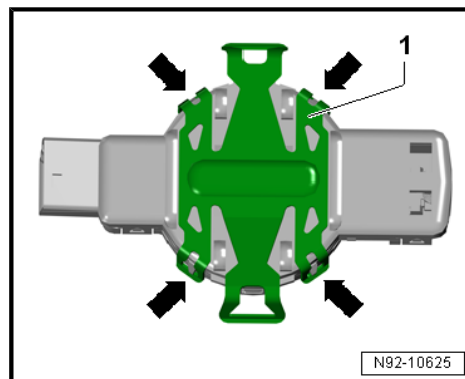

- Disconnect the upper part of the sleeve with an optical unit -1- by unlocking the retaining lugs -arrows- from the bottom part -2-.

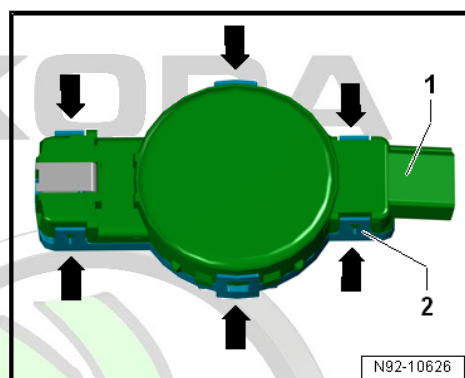

- Remove electronics of sensor for rain and light detection -2- from the old upper part of the sleeve -1- and insert into the new part.
- Lock the upper part of the sleeve with the optical unit and the protective cap to the bottom part of the sleeve.
- Install the sensor for rain and light detection  
⇒ ["2.5.2 Removing and installing sensor for rain and light detection , vehicles from CW 45.2015", page 99](#) .

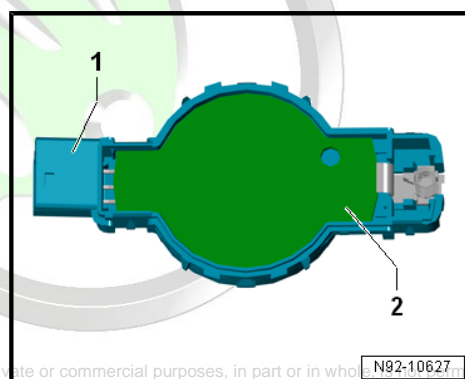

Protected by copyright. Copying for private or commercial purposes, in part or in whole, is prohibited unless authorised by ŠKODA AUTO A. S. ŠKODA AUTO A. S. does not guarantee or accept any liability with respect to the correctness of information in this document. Copyright by ŠKODA AUTO A. S. ©

## 2.6.2 Repairing the humidity, rain and light detection sensor - made by Valeo



### Note

*If the gel cushion is damaged/dirty, replace the self-adhesive gel cushion.*

### Work procedure

- Remove the air humidity, rain and light detector sensor  
⇒ ["2.5.2 Removing and installing sensor for rain and light detection , vehicles from CW 45.2015", page 99](#) .



- Carefully remove the gel cushion -2- or residues from the sensor -1-.



**Caution**

*The surface of the sensor must be completely free of foil residues.*

- Clean the sensor surface with cleaning solution.

- Remove the foil -3- from the cushion -2-.

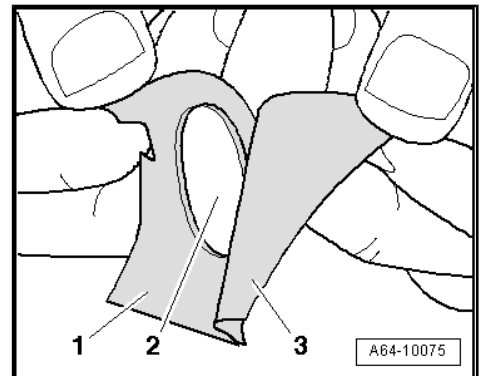
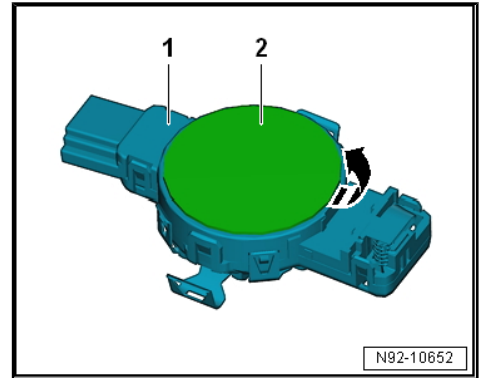

# ŠKODA

- Attach cushion -2- with the protective foil -1- on the sensor -3-.

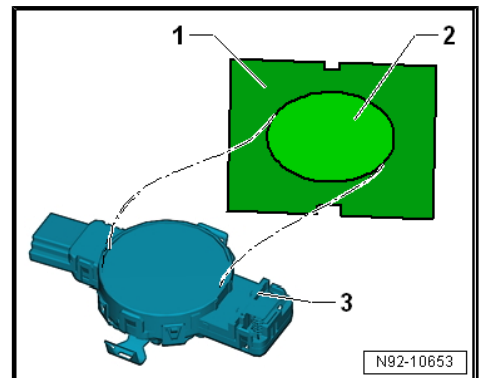
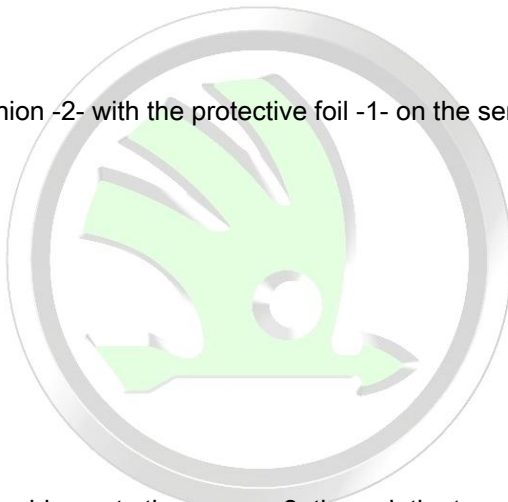

- Press the cushion onto the sensor -2- through the transparent foil -1-, so that there are no bubbles between the foil and sensor.

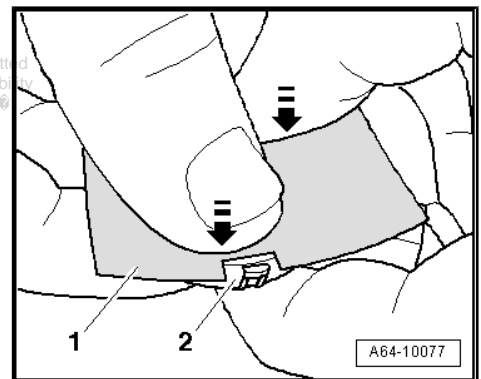



- Carefully pull the transparent protective foil -1- off the cushion -2-.
- Install the air humidity, rain and light detector sensor  
⇒ [“2.5.2 Removing and installing sensor for rain and light detection , vehicles from CW 45.2015”, page 99 .](#)

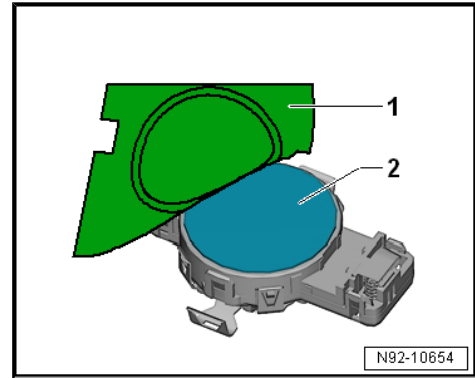

# ŠKODA



Protected by copyright. Copying for private or commercial purposes, in part or in whole, is not permitted unless authorised by ŠKODA AUTO A. S. ŠKODA AUTO A. S. does not guarantee or accept any liability with respect to the correctness of information in this document. Copyright by ŠKODA AUTO A. S. ©



### 3 Rear window wiper system

⇒ [“3.1 Removing and installing the windscreen wiper arm and setting its final position”, page 105](#)

⇒ [“3.2 Removing and installing rear window wiper motor”, page 105](#)

#### 3.1 Removing and installing the windscreen wiper arm and setting its final position

##### Removing

- Fold open the cap and release the nut -arrow-.
- If the wiper arm does not detach by moving laterally from the cone, then remove the spray nozzle  
 ⇒ [“1.4 Removing and installing the spray nozzle for rear window washer system”, page 91](#) and use a commercially available extractor in order to remove the wiper arm.

##### Install

- Switch rear window wiper motor on and off and run until it is in park position.

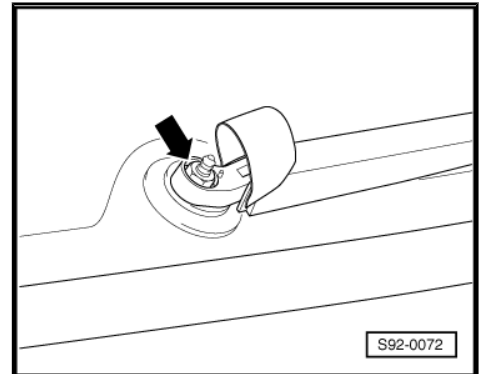

- Position the wiper arm onto the wiper motor shaft in such a way that the value -A- is  $35 \pm 2$  mm.
- Tighten the fixing nuts.
- Re-install the spray nozzle in case it was removed  
 ⇒ [“1.4 Removing and installing the spray nozzle for rear window washer system”, page 91](#) .

##### Tightening torques

Fixing nut for wiper arm	12 Nm
--------------------------	-------

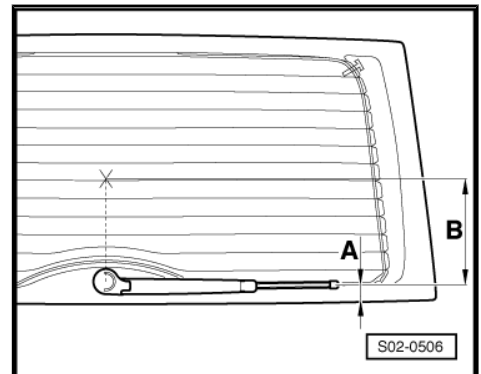

#### 3.2 Removing and installing rear window wiper motor

##### Removing

- Switch off the ignition and all electrical components.
- Remove windscreen wiper arm  
 ⇒ [“3.1 Removing and installing the windscreen wiper arm and setting its final position”, page 105](#) .
- Remove the bottom tailgate trim panel ⇒ Body Work; Rep. gr. 70 .



- Unplug connector -1- at wiper motor.
- To unlock turn the locking clip at the hose connection and separate hose with angular piece -2-.
- Unscrew screws -arrows- and remove wiper motor.

**Install**

Installation is performed in the reverse order, pay attention to the following points:

Take fitting position of implementation into account:

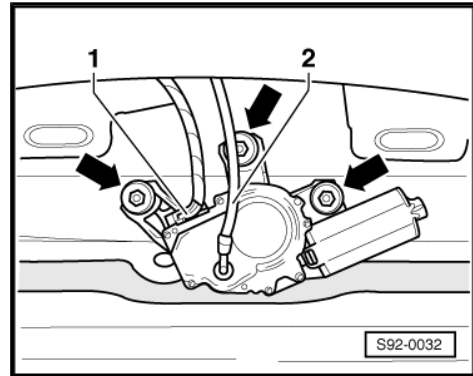

- Recess in the rear window implementation -arrow - is located at the bottom from the inside, see Fig.

**Tightening torques**

Fixing screws for wiper motor	7 Nm
-------------------------------	------

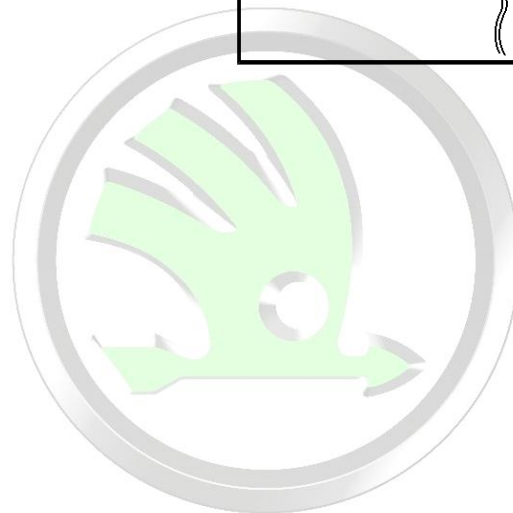
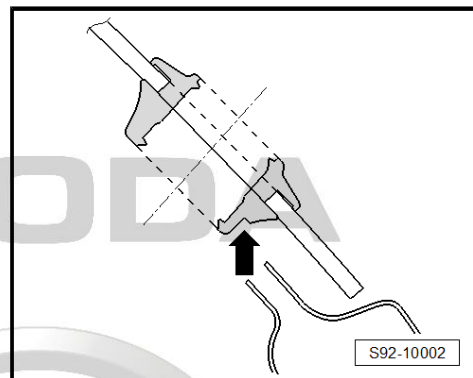

Protected by copyright. Copying for private or commercial purposes, in part or in whole, is not permitted unless authorised by ŠKODA AUTO A. S. ŠKODA AUTO A. S. does not guarantee or accept any liability with respect to the correctness of information in this document. Copyright by ŠKODA AUTO A. S. ©

## 4 Headlamp cleaning system

Summary of components - Components of the headlight washing system ⇒ Electronic Catalogue of Original Parts .

⇒ [“4.1 Removing and installing headlight cleaning system pump V11”](#), page 107

⇒ [“4.2 Removing and installing the lift cylinder for spray nozzles of headlight”](#), page 107

⇒ [“4.3 Bleed the headlamp cleaning system”](#), page 107

### 4.1 Removing and installing headlight cleaning system pump - V11-

The removal and installation of the pump is described in ⇒ [“1.2 Remove and install reservoir, pumps and sensor for washer fluid level”](#), page 89 .

After installing the pump bleed the headlamp cleaning system ⇒ [“4.3 Bleed the headlamp cleaning system”](#), page 107 .

### 4.2 Removing and installing the lift cylinder for spray nozzles of headlight

#### Removing

- Pull the spray nozzles with cover slightly out of the bumper by uniformly gripping on both sides of the cover -1-, then grip the spray nozzles and pull out up to the stop.
- Release catches -arrows- and slide out the cover from the spray nozzles.
- Remove front bumper ⇒ Body Work; Rep. gr. 63 .

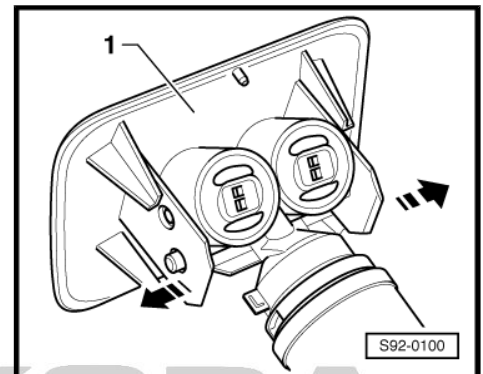

- Press off the catches arrows -A- using a small screwdriver and push the lift cylinder -1- out of the bumper arrow -B-.

#### Install

Installation is performed in the reverse order, pay attention to the following points:

- Push the lift cylinder into the brackets in the bumper until it clicks audibly into place.
- Pull out the spray nozzle and clip on the cover.
- Hoses with angled pieces must click audibly into the connections on the lift cylinders for spray nozzles.
- After completing the assembly work bleed the headlamp cleaning system ⇒ [“4.3 Bleed the headlamp cleaning system”](#), page 107 .

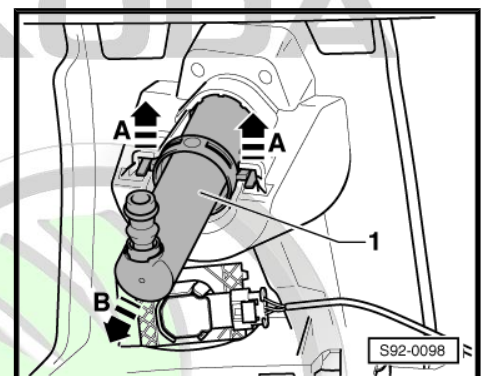

### 4.3 Bleed the headlamp cleaning system

After installation or when it is first put into service the headlamp cleaning system must be bled, in order to guarantee a perfect operation.

- Fill washer fluid reservoir and headlight washer reservoir.



- Start engine.
- Switch on headlight.
- Operate headlamp cleaning system several times (3 - 5 pulses for an operating duration of each 3 s).
- If necessary repeat this bleeding procedure until a perfect functioning of the lift cylinders for headlamp cleaning system and for spray nozzles is achieved.

# ŠKODA



Protected by copyright. Copying for private or commercial purposes, in part or in whole, is not permitted unless authorised by ŠKODA AUTO A. S. ŠKODA AUTO A. S. does not guarantee or accept any liability with respect to the correctness of information in this document. Copyright by ŠKODA AUTO A. S. ©

## 94 – Lights, bulbs, switches - exterior

### 1 Headlights - halogen headlights

⇒ [“1.1 Summary of components headlight - vehicles up to MY 2013”, page 109](#)

⇒ [“1.2 Summary of components headlight - vehicles as of MY 2014”, page 111](#)

⇒ [“1.3 Removing and installing headlight”, page 111](#)

⇒ [“1.4 Adjusting headlights”, page 113](#)

⇒ [“1.5 Replacing light bulbs in the headlight - vehicles up to MY 2013”, page 113](#)

⇒ [“1.6 Replacing light bulbs in the headlight - vehicles as of MY 2014”, page 117](#)

⇒ [“1.7 Change headlight for right-hand / left-hand traffic”, page 122](#)

⇒ [“1.8 Replace headlight fixing brackets”, page 124](#)

⇒ [“1.9 Removing and installing headlight range control motor”, page 125](#)

#### 1.1 Summary of components headlight - vehicles up to MY 2013

Description of the function:



**1 - Light bulb for daylight driving light P13W**

- Renew  
⇒ [“1.5.5 Replacing bulb for daylight driving light P13W”, page 117](#) .

**2 - Light bulb for fog light H7**

- Renew  
⇒ [“1.5.4 Replacing bulb for fog light H7”, page 116](#) .

**3 - Rubber cap**

**4 - Control motor for headlamp range control - V48- left or - V49- right**

- Removing and installing  
⇒ [“1.9 Removing and installing headlight range control motor”, page 125](#) .

**5 - Light bulb for low beam light H4**

- Renew  
⇒ [“1.5.1 Replacing bulb for main beam and low beam H4”, page 113](#) .

**6 - Plastic cap**

**7 - Light bulb for the parking light W5W**

- Renew  
⇒ [“1.5.2 Replacing W5W bulb for the parking light”, page 114](#) .

**8 - Bolts**

- 1.5 Nm

**9 - Cap for turn signal bulb**

**10 - O-ring**

**11 - Light bulb for turn signal light HPC24WY**

- Renew ⇒ [“1.5.3 Replacing bulb for the turn signal light”, page 115](#) .

**12 - Headlight housing**

- Removing and installing ⇒ [“1.3 Removing and installing headlight”, page 111](#)
- adjust ⇒ [“1.4 Adjusting headlights”, page 113](#)

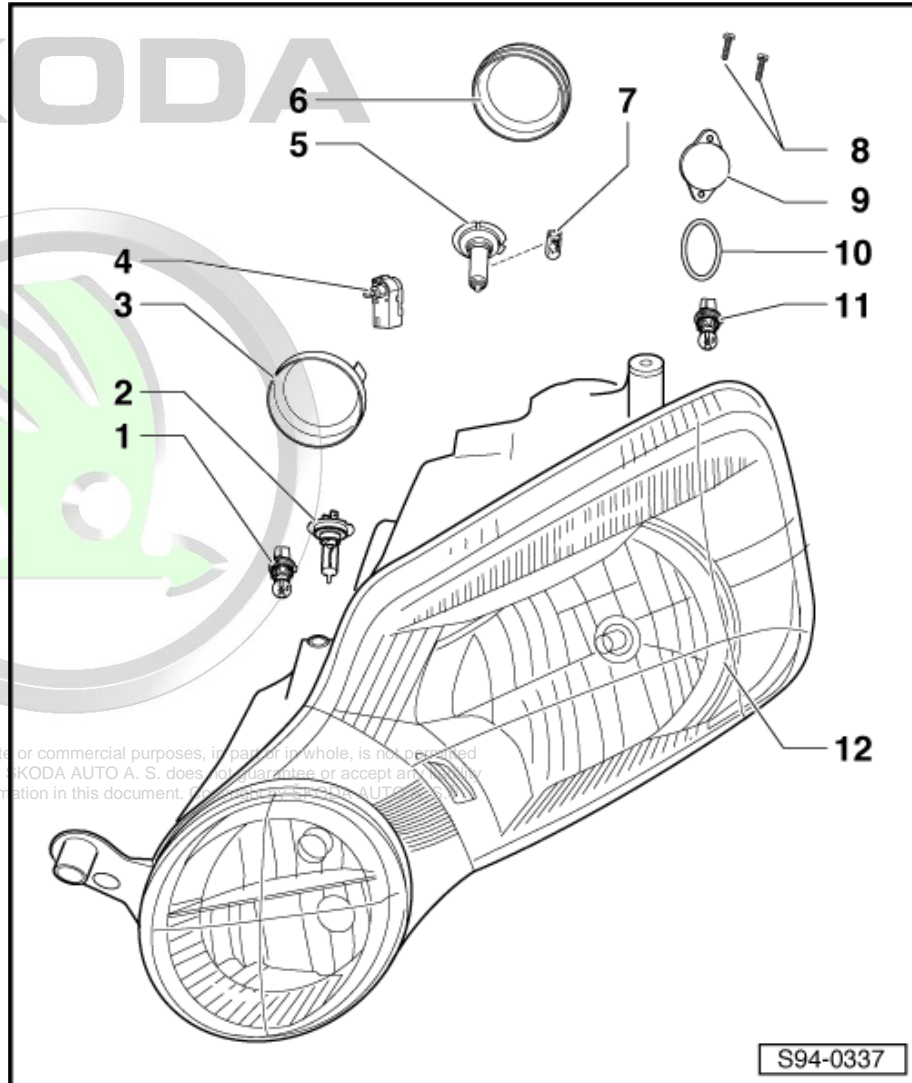

## 1.2 Summary of components headlight - vehicles as of MY 2014

### 1 - Headlight housing

- Removing and installing  
⇒ [“1.3 Removing and installing headlight”, page 111](#)
- adjust  
⇒ [“1.4 Adjusting headlights”, page 113](#)

### 2 - Plastic cap

### 3 - Light bulb for main beam H7

- Renew  
⇒ [“1.6.2 Replacing bulb for main beam H7”, page 118](#)

### 4 - Light bulb for the turn signal light PY24W

- Replacement set- light bulb, cap, bolts, seal
- Renew  
⇒ [“1.6.4 Replace bulb for turn signal light PWY24W”, page 121](#)

### 5 - Headlight range control motor

- Removing and installing  
⇒ [“1.9 Removing and installing headlight range control motor”, page 125](#)

### 6 - Light bulb for low beam H7 LL (LL - Long-life)

- Renew  
⇒ [“1.6.1 Replacing H7LL bulb for low beam light”, page 117](#)

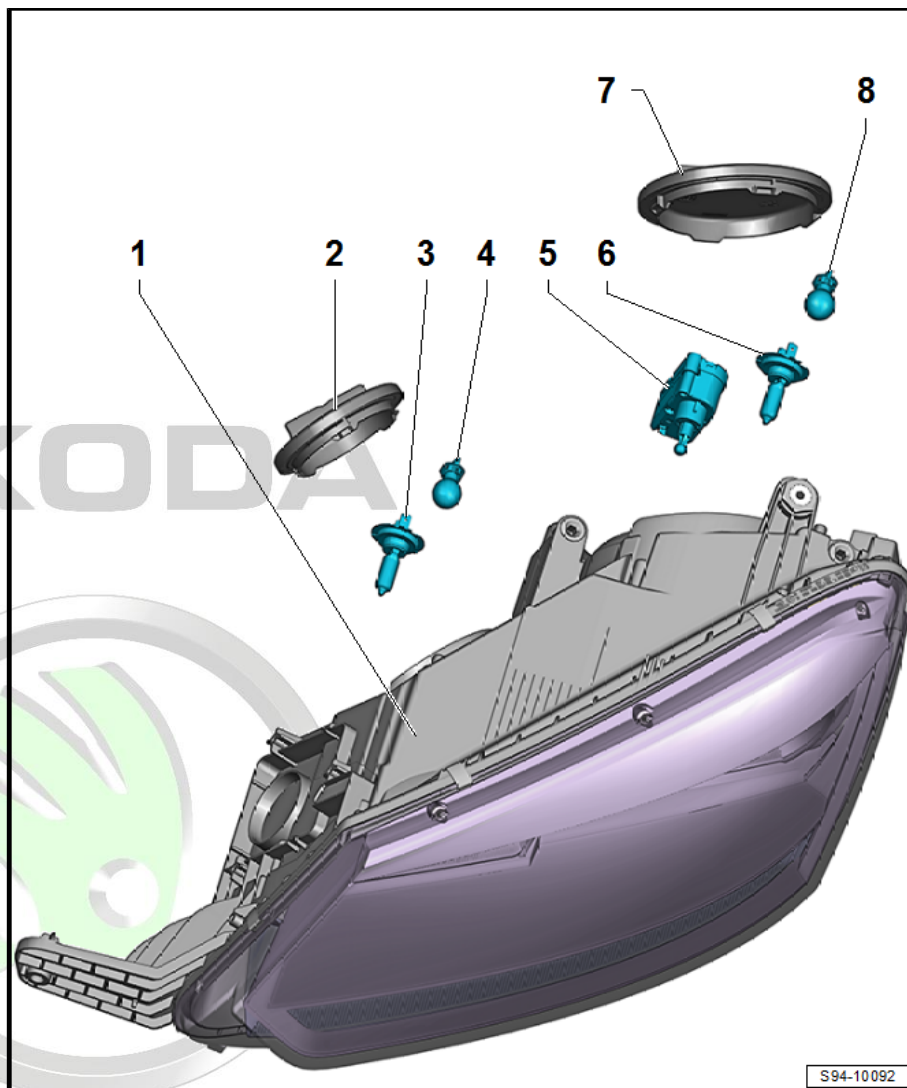

### 7 - Plastic cap

copyright. Copying for private or commercial purposes, in part or in whole, is not permitted unless authorised by SKODA AUTO A. S. SKODA AUTO A. S. does not guarantee or accept any liability

### 8 - Bulb for daytime running light and side light PW24W

- Renew ⇒ [“1.6.3 Replace bulb for daytime running light and side light PW24W”, page 120](#)

## 1.3 Removing and installing headlight

### Removing

- Switch off the ignition and all electrical components.
- Remove front bumper ⇒ Body Work; Rep. gr. 63 .
- Unplug the connector from the headlight.
- Unscrew fixing screws -arrows-:



Vehicles up to MY 2013

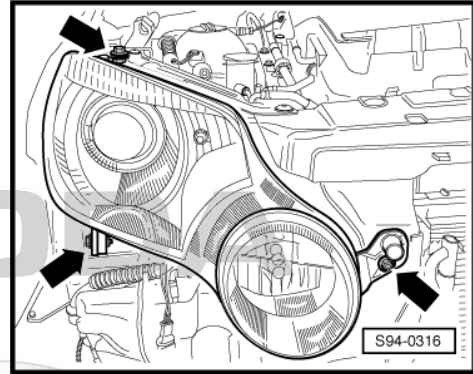

Vehicles as MY 2014

- Remove the headlight.

**Install**

- Slightly fasten the headlight with screws -A- and -B-:

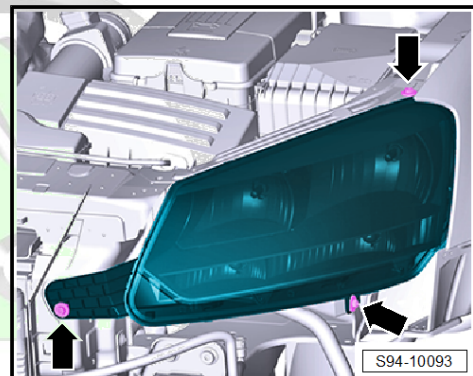

Vehicles up to MY 2013

Protected by copyright. Copying for private or commercial use without the express written permission of ŠKODA AUTO A. S. ŠKODA AUTO A. S. does not accept any liability with respect to the correctness of information in this document. Copyright © ŠKODA AUTO A. S. 2016

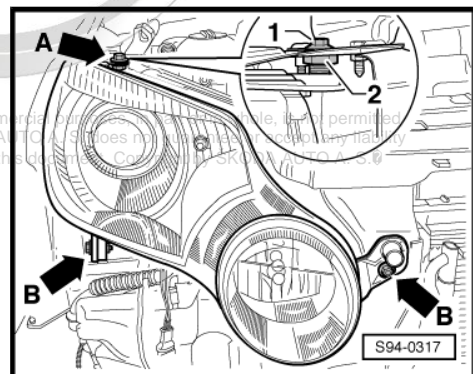

Vehicles as MY 2014

- Align the headlight according to the contours of the wing (maintain the gap size => Body Repairs; Rep. gr. 00 ).

Slacken the fixing screw -A (1)- to align the headlight and subsequently change the height of the stop by turning the adjusting nut -2- (left-hand thread).

- After aligning the headlight according to the contours of the vehicle body, fasten all the fixing screws for the headlight.
- Install bumper.
- Check the headlight beam setting, adjust where necessary => Maintenance ; Booklet Yeti .

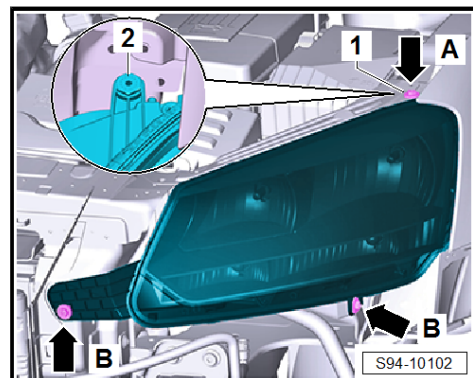

**Tightening torques**

Headlight fixing screws	3.5 Nm
-------------------------	--------

## 1.4 Adjusting headlights



Note

*The nominal values, the work procedure and the required workshop equipment for headlight beam setting are described in the ⇒ Repair work in the strictest sense ⇒ Maintenance ; Booklet Yeti .*

## 1.5 Replacing light bulbs in the headlight - vehicles up to MY 2013

⇒ ["1.5.1 Replacing bulb for main beam and low beam H4", page 113](#)

⇒ ["1.5.2 Replacing W5W bulb for the parking light", page 114](#)

⇒ ["1.5.3 Replacing bulb for the turn signal light ", page 115](#)

⇒ ["1.5.4 Replacing bulb for fog light H7", page 116](#)

⇒ ["1.5.5 Replacing bulb for daylight driving light P13W", page 117](#)

### 1.5.1 Replacing bulb for main beam and low beam H4



**WARNING**

*The H4 light bulb is pressurized and can burst when changing the bulb. It is recommended to wear gloves and safety glasses when changing bulbs.*



Note

- ◆ *Do not touch the glass when installing the light bulb. Your fingers will leave traces of grease on the glass which then evaporate when the bulb is switched on causing it to cloud.*
- ◆ *When installing the cover, pay attention to the correct fitting. Water ingress will destroy the headlight.*
- Switch off the ignition and all electrical components.
- Turn cap -1- -arrow- and remove.

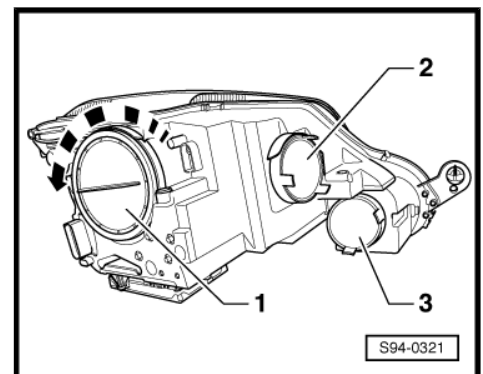



- Unplug connector -1-.
- Press the wire spring clamp -2- -arrow- and tilt it out.
- Remove the defective light bulb -3- and replace it.
- Check the headlight beam setting, adjust where necessary  
⇒ Maintenance ; Booklet Yeti .

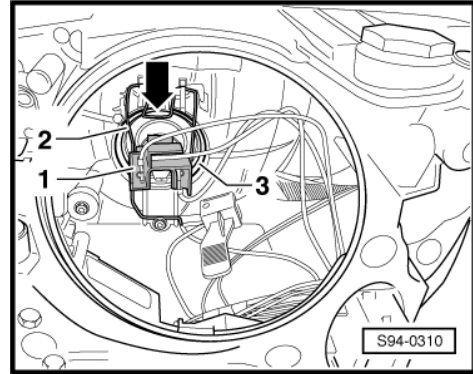

## 1.5.2 Replacing W5W bulb for the parking light



### Note

- ◆ *Do not touch the glass when installing the light bulb. Your fingers will leave traces of grease on the glass which then evaporate when the bulb is switched on causing it to cloud.*
- ◆ *When installing the cover, pay attention to the correct fitting. Water ingress will destroy the headlight.*
- Switch off the ignition and all electrical components.
- Turn cap -1- -arrow- and remove.

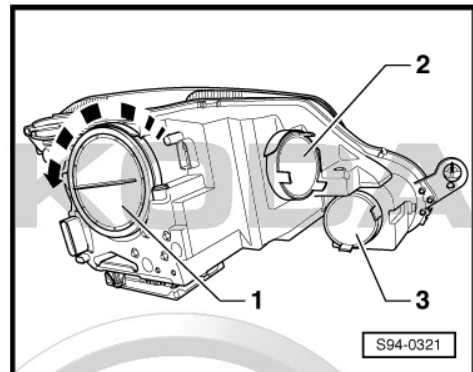

- Pull connector with bulb for the parking light -1- out of the headlight -arrow-.

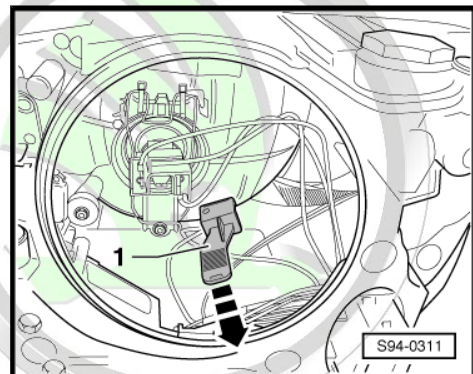

- Remove the defective light bulb -2- from the socket -1-.
- After replacing the bulb, press socket and bulb fully into the headlight.

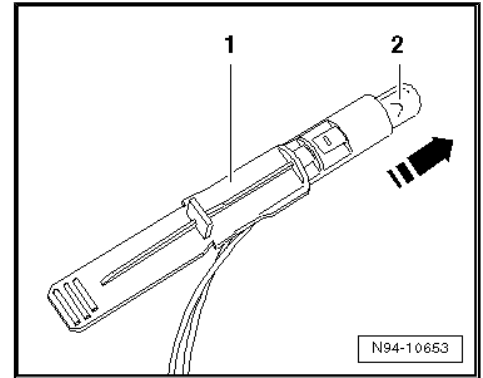

### 1.5.3 Replacing bulb for the turn signal light

**i** Note

- ◆ *Do not touch the glass when installing the light bulb. Your fingers will leave traces of grease on the glass which then evaporate when the bulb is switched on causing it to cloud.*
- ◆ *When installing the cover, pay attention to the correct fitting. Water ingress will destroy the headlight.*
- ◆ Vehicles up to MY 2013 - bulb type "HPC24WY"
- ◆ Vehicles as of MY 2014 - bulb type "PWY24W"

**i** Note

- ◆ *Do not touch the glass when installing the light bulb. Your fingers will leave traces of grease on the glass which then evaporate when the bulb is switched on causing it to cloud.*
- ◆ *When installing the cover, pay attention to the correct fitting. Water ingress will destroy the headlight.*
- ◆ *For changing the bulb of the turn signal light, a repair kit is supplied - light bulb, O-ring, cap and fixing screws.*

- Switch off the ignition and all electrical components.
- Remove the headlight with the defective light bulb  
 => ["1.3 Removing and installing headlight", page 111](#) .
- Lever off cap for turn signal bulb -1- using a screwdriver. Proceed carefully so that the remainders of the cover do not grip into the headlight housing.
- Turn bulb socket -arrow- and remove from the headlight.
- Disconnect the plug -2- and replace the defective light bulb.

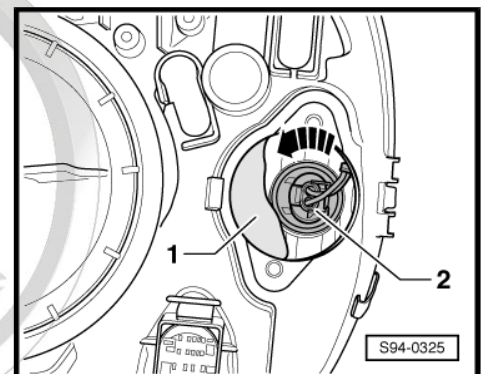



- After installing the new light bulb -4- attach the cap -2- with the O-ring -3- with screws -1-.
- Further installation occurs in reverse order.

**Tightening torques**

Fixing screws for lens	1.5 Nm
------------------------	--------

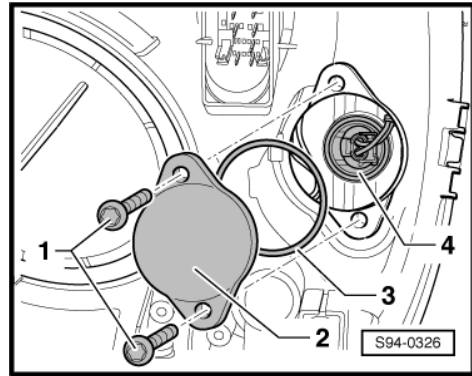

**1.5.4 Replacing bulb for fog light H7**



**WARNING**

*The H7 light bulb is pressurized and can burst when changing the bulb. It is recommended to wear gloves and safety glasses when changing bulbs.*



**Note**

- ◆ Do not touch the glass when installing the light bulb. Your fingers will leave traces of grease on the glass which then evaporate when the bulb is switched on causing it to cloud.
- ◆ When installing the cover, pay attention to the correct fitting. Water ingress will destroy the headlight.
- Switch off the ignition and all electrical components.
- Remove rubber cap -3-.

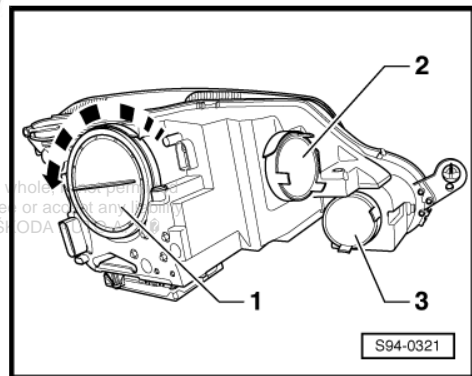

Protected by copyright. Copying for private or commercial purposes, in part or in whole, is permitted without the prior written consent of SKODA AUTO A. S. SKODA AUTO A. S. does not guarantee or accept any responsibility with respect to the correctness of information in this document. Copyright by SKODA AUTO A. S.

- Release and remove the bulb -2- from the catches by pendular movement and pulling force -arrows-.
- Unplug connector -1-.
- Replace defective light bulb.

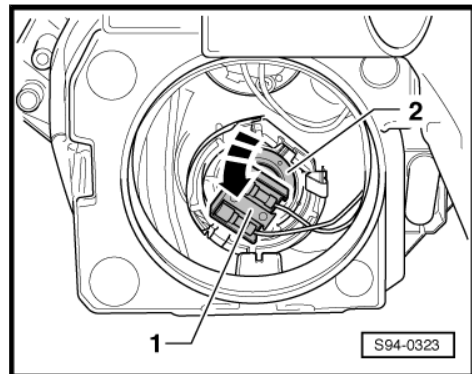



## 1.5.5 Replacing bulb for daylight driving light P13W

### Note

- ◆ *Do not touch the glass when installing the light bulb. Your fingers will leave traces of grease on the glass which then evaporate when the bulb is switched on causing it to cloud.*
- ◆ *When installing the cover, pay attention to the correct fitting. Water ingress will destroy the headlight.*

- Switch off the ignition and all electrical components.
- Remove rubber cap -3-.

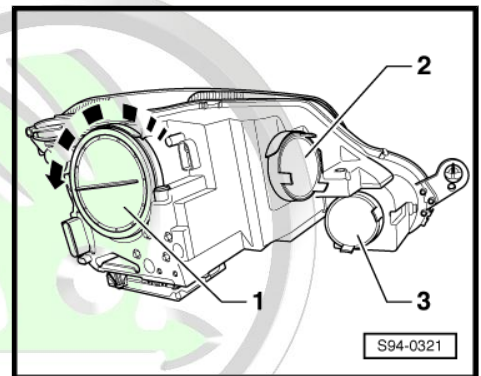

- Turn socket with bulb -1- and remove from the headlight housing -arrow-.
- Disconnect plug.
- Replace defective light bulb.

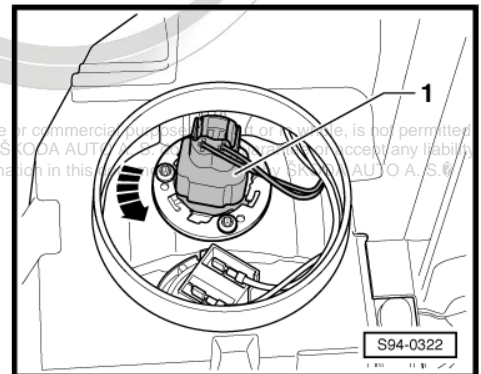

Protected by copyright. Copying for private or commercial purposes without the prior written consent of SKODA AUTO A. S. SKODA AUTO A. S. accepts any liability with respect to the correctness of information in this manual.

## 1.6 Replacing light bulbs in the headlight - vehicles as of MY 2014

⇒ ["1.6.1 Replacing H7LL bulb for low beam light", page 117](#)

⇒ ["1.6.2 Replacing bulb for main beam H7", page 118](#)

⇒ ["1.6.3 Replace bulb for daytime running light and side light PW24W", page 120](#)

⇒ ["1.6.4 Replace bulb for turn signal light PWY24W", page 121](#)

### 1.6.1 Replacing H7LL bulb for low beam light



#### WARNING

*The H7LL bulb is pressurized and can burst when changing it. It is recommended to wear gloves and safety glasses when changing bulbs.*



**Note**

- ◆ *Do not touch the glass when installing the light bulb. Your fingers will leave traces of grease on the glass which then evaporate when the bulb is switched on causing it to cloud.*
- ◆ *When installing the cover, pay attention to the correct fitting. Water ingress will destroy the headlight.*

- Switch off the ignition and all electrical components.
- Turn the cover -1- towards the left and remove.

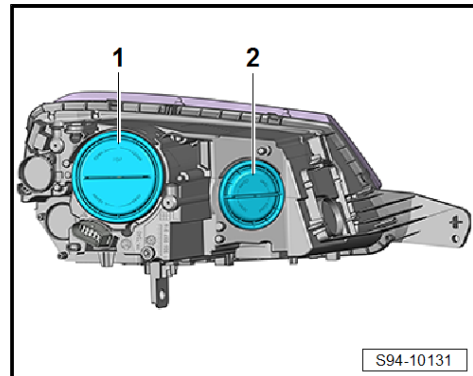

- Release and remove the bulb -2- from the catches by pendular movement and pulling force -arrows-.
- Disconnect plug.
- Press new lamp -2- into the assembly opening until the catches -arrows- are locked.
- Mount plug -1-.

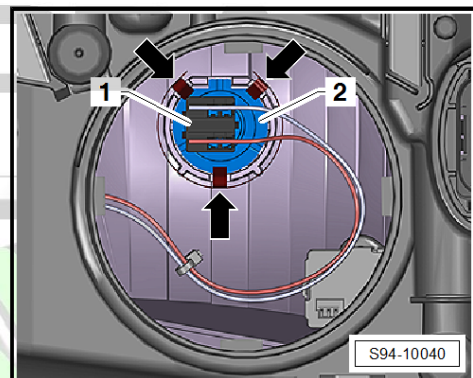

**Note**

*Check seal for damage and observe correct installation position of caps, see fig.*

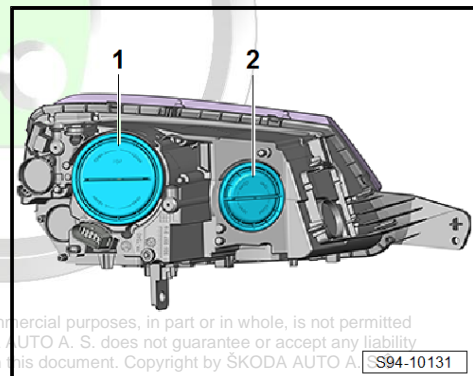

Protected by copyright. Copying for private or commercial purposes, in part or in whole, is not permitted unless authorised by ŠKODA AUTO A. S. ŠKODA AUTO A. S. does not guarantee or accept any liability with respect to the correctness of information in this document. Copyright by ŠKODA AUTO A. S.

## 1.6.2 Replacing bulb for main beam H7



**WARNING**

*The H7 light bulb is pressurized and can burst when changing the bulb. It is recommended to wear gloves and safety glasses when changing bulbs.*



**i Note**

- ◆ Do not touch the glass when installing the light bulb. Your fingers will leave traces of grease on the glass which then evaporate when the bulb is switched on causing it to cloud.
- ◆ When installing the cover, pay attention to the correct fitting. Water ingress will destroy the headlight.

- Switch off the ignition and all electrical components.
- To get better access to the bulb remove:

on the left-hand side - sleeve with air filter⇒ Engine; Rep. gr. 23

on the right-hand side on vehicles with TDI engine - the fuel filter and place down to one side, do not disconnect the hoses ⇒ Engine; Rep. gr. 20 .

- Turn the cover -2- towards the left and remove.

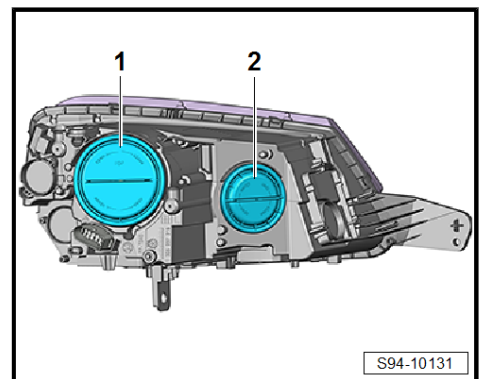

ŠKODA

- Disconnect bulb and remove connector -1-.
- Release and remove the bulb -2- from the catches by pendular movement and pulling force -arrows-.
- Press new lamp -2- into the assembly opening until the catch-arrows- are locked.
- Mount plug -1-.

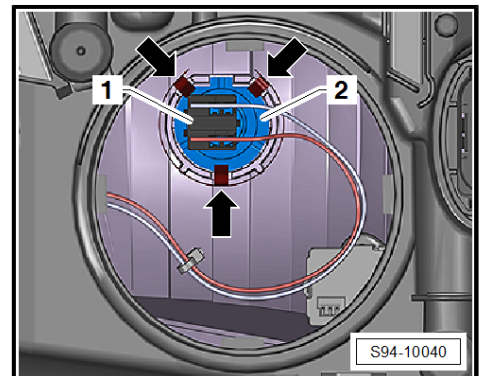

**i Note**

Check seal for damage and observe correct installation position of caps, see fig.

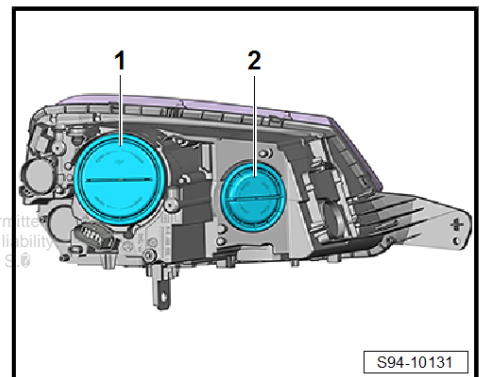

Protected by copyright. Copying for private or commercial purposes, in part or in whole, is not permitted unless authorised by ŠKODA AUTO A. S. ŠKODA AUTO A. S. does not guarantee or accept any liability with respect to the correctness of information in this document. Copyright by ŠKODA AUTO A. S.



### 1.6.3 Replace bulb for daytime running light and side light PW24W

**i** Note

- ◆ Do not touch the glass when installing the light bulb. Your fingers will leave traces of grease on the glass which then evaporate when the bulb is switched on causing it to cloud.
- ◆ When installing the cover, pay attention to the correct fitting. Water ingress will destroy the headlight.

- Remove headlight  
⇒ ["1.3 Removing and installing headlight", page 111](#) .
- Turn the cover -1- towards the left and remove.

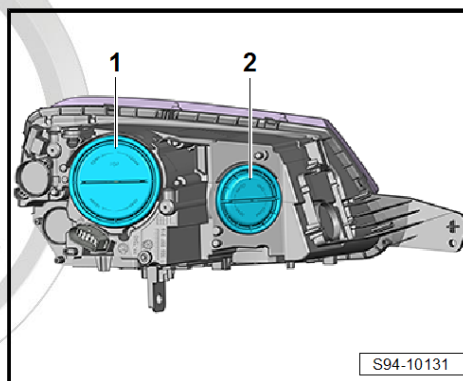

- Pull on the connecting cable -arrow- to undo the socket with bulb -1- from the parable
- Remove defective light bulb from the socket and replace.

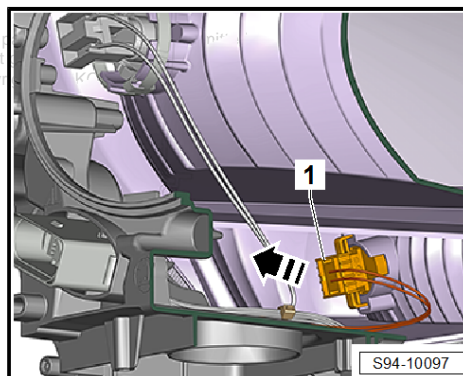

- Press socket with a new bulb into the assembly opening until the stop -arrow-, make sure the socket is in the correct position, see fig.

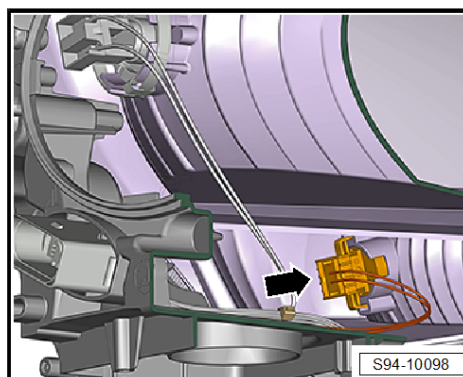

**i** Note

Check seal for damage and observe correct installation position of caps, see fig.

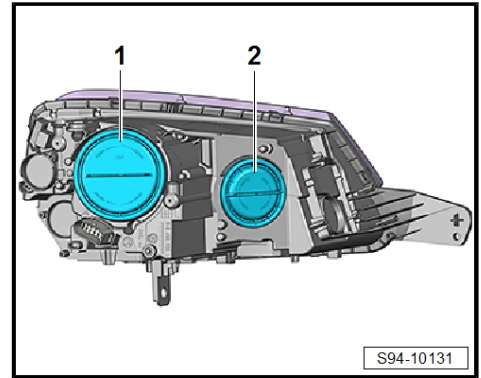

### 1.6.4 Replace bulb for turn signal light PWY24W

**i** Note

- ◆ Do not touch the glass when installing the light bulb. Your fingers will leave traces of grease on the glass which then evaporate when the bulb is switched on causing it to cloud.
- ◆ When installing the cover, pay attention to the correct fitting. Water ingress will destroy the headlight.

- Remove headlight  
 ⇒ ["1.3 Removing and installing headlight", page 111](#) .
- Turn the cover -2- towards the left and remove.

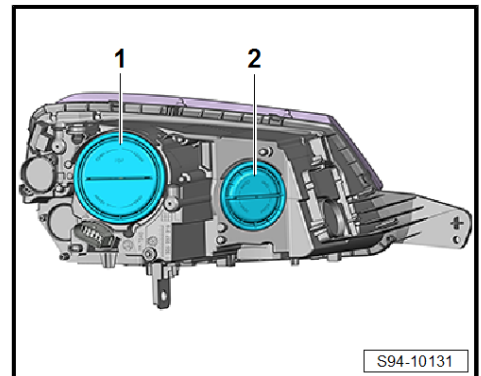
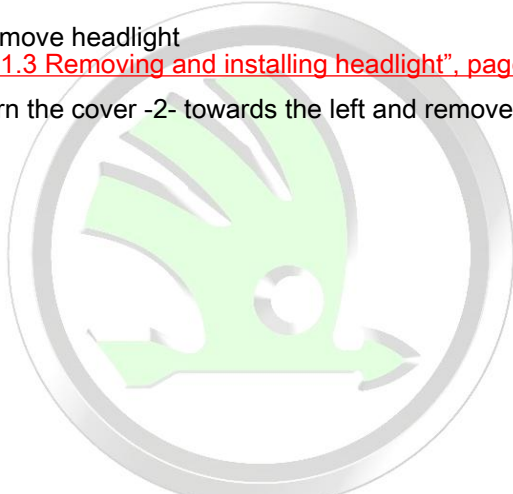

- Pull on the connecting cable -arrow- to undo the socket with bulb -1- from the parable.

Protected by copyright. Copying for private or commercial purposes, in part or in whole, is not permitted unless authorised by SKODA AUTO A.S. SKODA AUTO A.S. does not guarantee or accept any liability with respect to the correctness or completeness of this document. Copyright by SKODA AUTO A.S. ©

- Remove defective light bulb from the socket and replace.

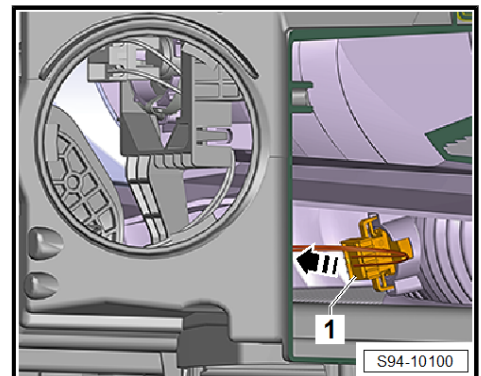



- Press socket with a new bulb into the assembly opening until the stop -arrow-, make sure the socket is in the correct position, see fig.

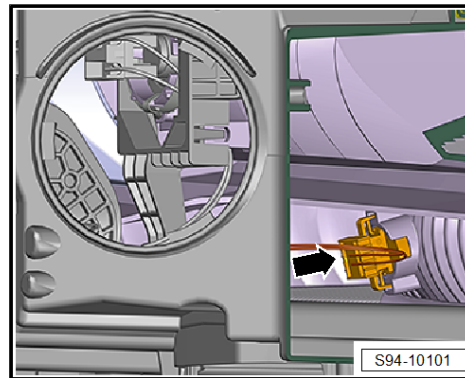

### Note

Check seal for damage and observe correct installation position of caps, see fig.

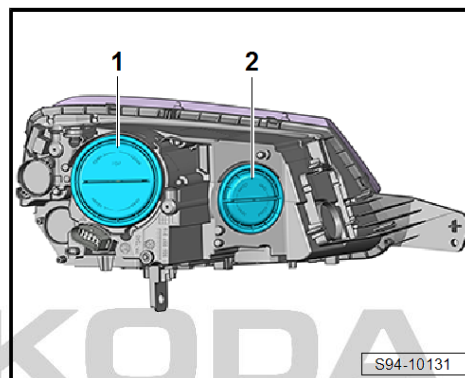

## 1.7 Change headlight for right-hand / left-hand traffic

⇒ [“1.7.1 Changing the headlamp - vehicles up to MY 2013”, page 122](#)

⇒ [“1.7.2 Changing the headlamp - vehicles as of MY 2014”, page 123](#)

### 1.7.1 Changing the headlamp - vehicles up to MY 2013

The halogen headlights should have self-adhesive foil glued over them when driving in countries which drive on the right or the left thereby preventing blinding of the drivers travelling in the opposite direction.



### Note

- ◆ *The lenses must be cleared of dirt and de-greased, e.g. with degreased white spirit solution, before sticking the foil.*
  - ◆ *When cleaning and gluing foils, the lens must remain cold for safety reasons.*
  - ◆ *The instructions “right” and/or “left” on the protective foils always refer to the front visibility towards the outside.*
- Remove protective film on the rear side of the adhesive foil.
  - Glue the self-adhesive foil, as shown in the figure, onto the parting plane -arrows- of the headlights.

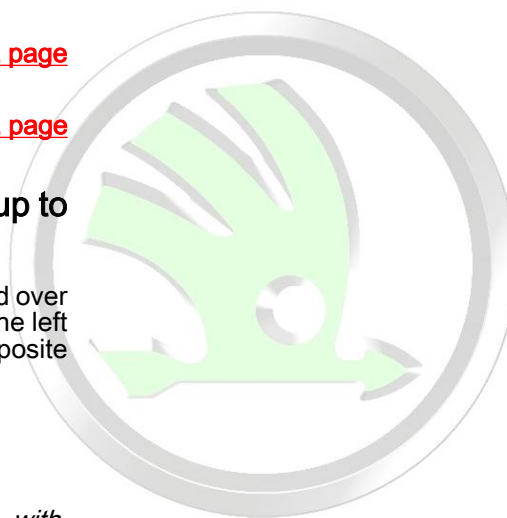

Left-hand drive in left-hand traffic:

- A - The headlight on the right
- B - The headlight on the left
- In area -1- press forcefully onto the lens.

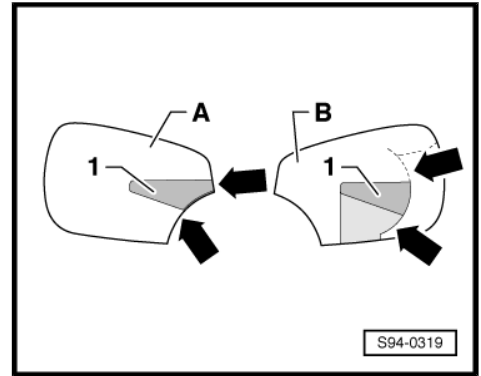

Right-hand drive in right-hand traffic:

- A - The headlight on the right
- B - The headlight on the left
- In area -2- press forcefully onto the lens.

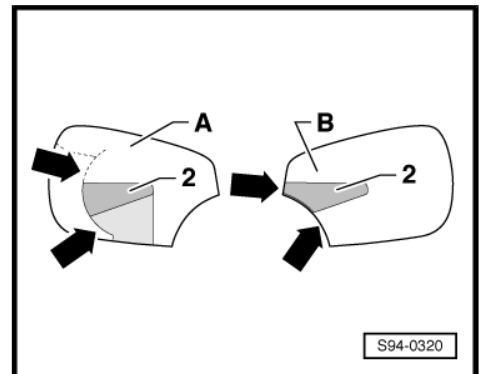

**i** Note

- ◆ Only a part of the protective film -1- or -2- remains on the lens (shown with a darker colour in the figure).
- ◆ Inform the customer about the corresponding notes for removing the residual adhesive after pulling off the protective foil, e.g. textiles soaked in isopropyl alcohol (do not use any aggressive solvent, which can damage the polycarbonate lenses).

## 1.7.2 Changing the headlamp - vehicles as of MY 2014

The halogen headlights should have self-adhesive foil glued over them when driving in countries which drive on the right or the left thereby preventing blinding of the drivers travelling in the opposite direction.

**i** Note

- ◆ The lenses must be cleared of dirt and de-greased, e.g. with de-greased white spirit solution, before sticking the foil.
- ◆ When cleaning and gluing foils, the lens must remain cold for safety reasons.
- ◆ The instructions "right" and/or "left" on the protective foils always refer to the front visibility towards the outside.
- Remove protective film on the rear side of the adhesive foil.
- Glue the self-adhesive foil, as shown in the figure, onto the parting plane of the headlight.

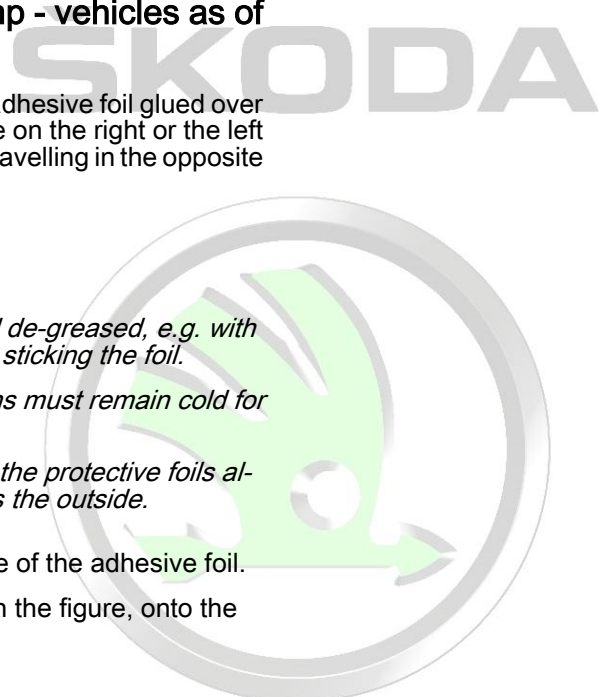



Left-hand drive in left-hand traffic:

- 1 - The headlight on the right
- 2 - The headlight on the left

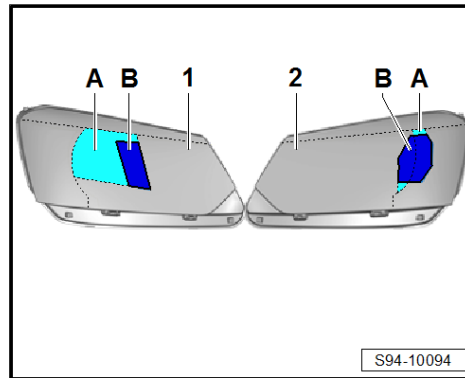

Right-hand drive in right-hand traffic:

- 1 - The headlight on the right
- 2 - The headlight on the left
- in area -B- press more forcefully onto the lens.
- Remove a part of the film -A- from the lens (only a part of the film -B- remains on the lens).

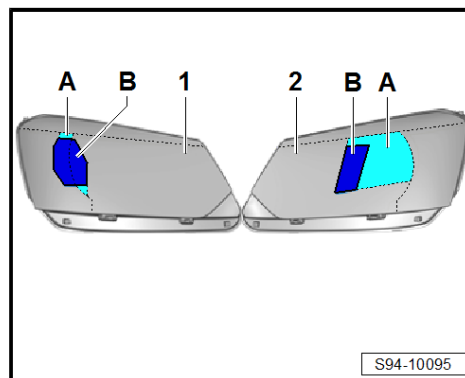

**Note**

Inform the customer about the corresponding notes for removing the residual adhesive after pulling off the protective foil, e.g. textiles soaked in isopropyl alcohol (do not use any aggressive solvent, which can damage the polycarbonate lenses).



## 1.8 Replace headlight fixing brackets

If the upper or the lower headlight fixing brackets are broken or damaged, they can be replaced by installing the repair kit. The complete headlight must not be replaced.



**Note**

- ◆ Before repairs check if the headlight has no other damage, as the repair would be senseless.
- ◆ The replacement brackets can be ordered separately see → *Electronic Catalogue of Original parts* .
- ◆ Before repairs the headlight must be removed ⇒ ["1.3 Removing and installing headlight", page 111](#) .
- ◆ After installing the headlight, adjust the headlight ⇒ ["1.4 Adjusting headlights", page 113](#) .



### Screw adjusting nut into the new bracket:

Before attaching to the headlight housing, an adjusting screw -2- must be screwed into the new bracket -1-.

The adjusting screw is designed to cut the thread into the new bracket.

The adjusting screw must be screwed into the bracket accurately and straight, otherwise there is a risk that the new bracket will break.

Protected by copyright. Copying for private or commercial purposes, in part or in whole, is not permitted without the prior written consent of ŠKODA AUTO A. S. ŠKODA AUTO A. S. does not guarantee or accept any liability with respect to the correctness of information in this document. Copyright by ŠKODA AUTO A. S.



To screw the adjusting screw -2- into the new bracket -1- accurately, use e.g. the vice jaws. Use e.g. the hex socket -4- from the tool set for support on one side. On the other side, use e.g. a piece of pipe, a washer, or screw etc. Pos. -3-.

Slowly screw the adjusting screw into the new bracket, while slowly tightening the vice jaws (a second mechanic is required for this step).

**Replace the original bracket with a new bracket:**

- Disconnect the remainder of the original bracket.
- Change the contact surface (grind off, remove by file) to allow a new bracket to be inserted.
- Install a new bracket -arrows- with adjusting screw already tightened flush to the profile and tighten the fixing screws.

**Tightening torques**

Fixing screws for new bracket	1.5 Nm
-------------------------------	--------

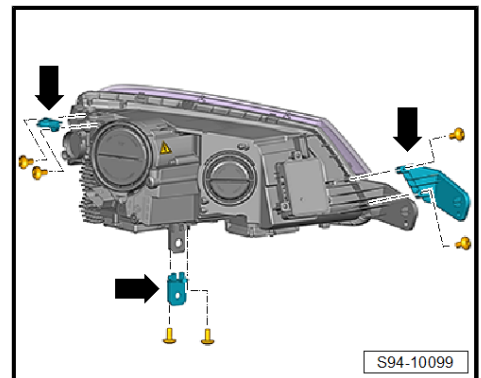
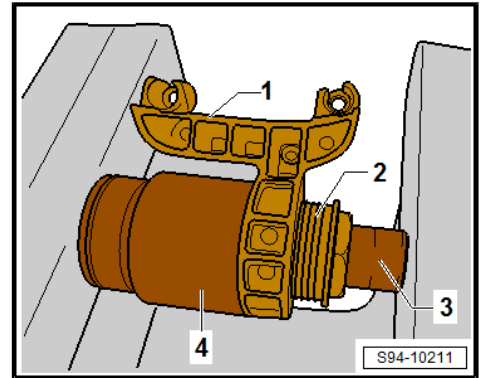

**1.9 Removing and installing headlight range control motor**

⇒ [“1.9.1 Removing and installing headlight range control motor - vehicles up to MY 2013”, page 125](#)

⇒ [“1.9.2 Removing and installing headlight range control motor - vehicles as of MY 2014”, page 126](#)

**1.9.1 Removing and installing headlight range control motor - vehicles up to MY 2013**

**Removing**

- Remove headlight with defective control motor  
 ⇒ [“1.3 Removing and installing headlight”, page 111](#) .
- Remove cover -1-.
- In order to facilitate an easier access to the control motor, remove the bulb for the low beam light  
 ⇒ [“1.5.1 Replacing bulb for main beam and low beam H4”, page 113](#) .

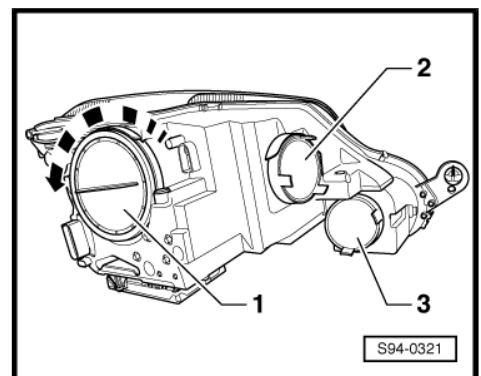
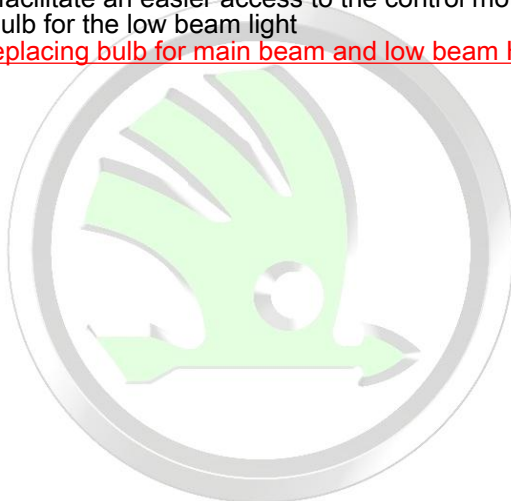



- Carefully break out the plugs (they must not fall into the headlight housing):
- ◆ Left headlight -1-
- ◆ Right headlight -2-
- Unscrew the fixing screws and then unhook the pressure element of the control motor -arrow-.
- Remove the control motor -3- and disconnect the plug.

**Install**

Installation is performed in the reverse order, pay attention to the following points:

- Replace the broken out plugs with the plugs from the repair kit.
- When installing the cover, pay attention to the correct fitting. Water ingress will destroy the headlight.
- Inspect proper operation.
- Set up the headlight ⇒ Maintenance ; Booklet Yeti .

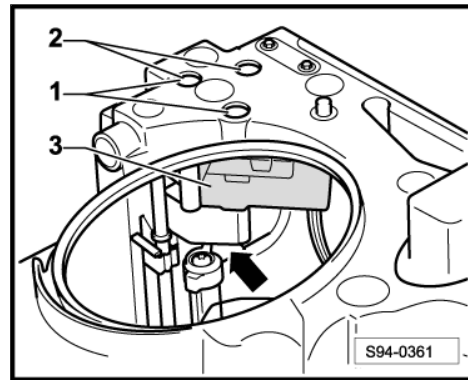

### 1.9.2 Removing and installing headlight range control motor - vehicles as of MY 2014

**Removing**

- Remove headlight with defective control motor ⇒ ["1.3 Removing and installing headlight", page 111](#) .
- Turn the cover -1- towards the left and remove.



**Note**

*On the right-hand headlight, the plug must be carefully via the fixing screw of the control motor and after assembly, the opening must be sealed with plugs from the repair kit, see ⇒ Catalogue of original parts .*

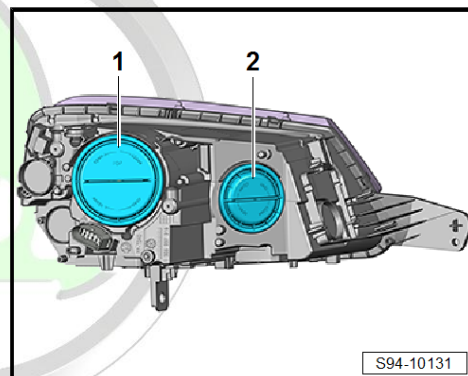

- Unscrew fixing screws -1-.
- Turn the control motor arrow -A- and swivel out.
- Push off the retaining tabs in direction of arrow -B- and unhook the pressure element of the control motor out of the bearing.
- Remove the control motor -2- and disconnect the plug -3-.

**Install**

Installation is performed in the reverse order, pay attention to the following points:

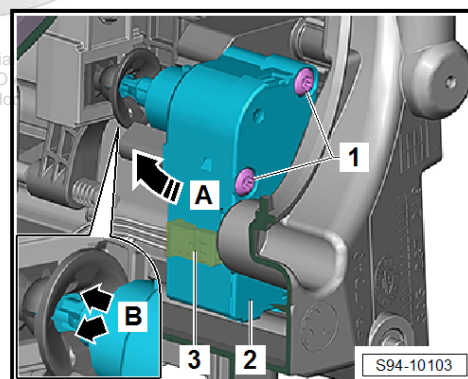



**Note**

*Check seal for damage and observe correct installation position of caps, see fig.*

- Inspect proper operation.
- Set up the headlight ⇒ Maintenance ; Booklet Yeti .

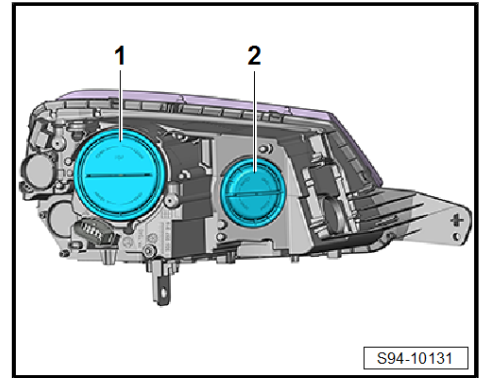

# ŠKODA



Protected by copyright. Copying for private or commercial purposes, in part or in whole, is not permitted unless authorised by ŠKODA AUTO A. S. ŠKODA AUTO A. S. does not guarantee or accept any liability with respect to the correctness of information in this document. Copyright by ŠKODA AUTO A. S.®



## 2 Headlights with Xenon discharge lamps

- ⇒ [“2.1 General description”, page 128](#)
- ⇒ [“2.2 Fault recognition and fault display”, page 129](#)
- ⇒ [“2.3 Summary of components headlight - vehicles up to MY 2013”, page 129](#)
- ⇒ [“2.4 Summary of components headlight - vehicles as of MY 2014”, page 131](#)
- ⇒ [“2.5 Removing and installing headlight”, page 132](#)
- ⇒ [“2.6 Adjusting headlights”, page 132](#)
- ⇒ [“2.7 Replacing light bulbs in the headlight - vehicles up to MY 2013”, page 132](#)
- ⇒ [“2.8 Replacing light bulbs in the headlight - vehicles as of MY 2014”, page 134](#)
- ⇒ [“2.9 Remove and install performance module for the headlight J667 left or J668 right”, page 136](#)
- ⇒ [“2.10 Removing and installing Control unit for daylight driving light and side light left J860 and J861 right”, page 138](#)
- ⇒ [“2.11 Removing and installing control unit for gas discharge lamp J343 left or J344 right”, page 138](#)
- ⇒ [“2.12 Removing and installing headlight range control motor”, page 139](#)
- ⇒ [“2.13 Change headlight for right-hand / left-hand traffic”, page 141](#)
- ⇒ [“2.14 Removing and installing the cornering light and headlight range control unit J745”, page 141](#)
- ⇒ [“2.15 Vehicle level sensor front left G78 and rear left G76”, page 142](#)
- ⇒ [“2.16 Replace headlight fixing brackets”, page 142](#)

### 2.1 General description



#### WARNING

*Observe use and safety instructions for gas discharge lamps*  
⇒ *Electrical System – general notes; Rep. gr. 94.*

Protected by copyright. Copying for private or commercial purposes in part or in whole, is not permitted without the prior written consent of the copyright holder. ŠKODA does not guarantee or accept any liability for the content of this document. Copyright by ŠKODA AUTO A. S.



#### Note

*When handling a fault it is absolutely essential to know the function and operation of the illumination system ⇒ Owner's manual Yeti.*

The headlights with Xenon discharge lamps are “bi-xenon lamps”, cornering light (AFS - Adaptive Frontlighting System).

The cornering light and headlight range control unit -J745- evaluates the following input data:

- ◆ Steering wheel angle and direction
- ◆ Vehicle speed

- ◆ Reversing lights on
- ◆ Switching on the headlight (low beam light or main beam light)
- ◆ Signals of the vehicle level sensor on the rear axle
- ◆ Start of the windscreen wipers
- ◆ individual wheel speeds
- ◆ Light detection sensor
- ◆ Rotary light switch

On the basis of this information, the cornering light and headlight range control unit controls the rotary and inclination movement of the headlights and the switching of the individual performance modules of the headlights.

Further information and description of function:

- ◆ ⇒ Owner's manual Yeti
- ◆ ⇒ Self-study programme No. 72 ; Škoda Yeti, introduction of the vehicle

## 2.2 Fault recognition and fault display



### Note

*In case of malfunctions of the headlight range control or the AFS system (Adaptive Frontlighting System) the warning light "light failure" flashes, see ⇒ Yeti Owner's manual .*

The system for variable front lighting is equipped with self-diagnosis, which facilitates the troubleshooting.

For fault finding use the ⇒ Vehicle diagnostic tester in the function "Targeted fault finding".

Perform the final control diagnosis in order to test the complete system ⇒ Vehicle diagnostic tester.

## 2.3 Summary of components headlight - vehicles up to MY 2013

Protected by copyright. Copying for private or commercial purposes, in part or in whole, is not permitted unless authorised by ŠKODA AUTO A. S. ŠKODA AUTO A. S. does not guarantee or accept any liability with respect to the correctness of information in this document. Copyright by ŠKODA AUTO A. S. ©



**1 - Light bulb for the parking light W5W BL(blue glass)**

- Renew  
⇒ [“2.7.2 Replacing bulb W5W BL for the parking light”, page 133](#) .

**2 - Rubber cap**

**3 - Light bulb for daylight driving light P13W**

- Renew  
⇒ [“1.5.5 Replacing bulb for daylight driving light P13W”, page 117](#) .

**4 - Light bulb for fog light H7**

- Renew  
⇒ [“1.5.4 Replacing bulb for fog light H7”, page 116](#) .

**5 - Rubber cap**

**6 - Control motor for headlamp range control - V48- left or - V49- right**

- Removing and installing  
⇒ [“2.12 Removing and installing headlight range control motor”, page 139](#)

**7 - Cornering light and headlight range control, control unit - J745-**

- behind the storage tray in the dash panel on the front passenger side
- Removing and installing  
⇒ [“2.14 Removing and installing the cornering light and headlight range control unit J745”, page 141](#)

**8 - Gas discharge lamp with integrated high voltage ignition unit D1S**

- Renew ⇒ [“2.7.1 Replacing gas discharge lamp with integrated high voltage ignition unit”, page 132](#) .

**9 - Plastic cap**

**10 - Bolts**

- 1.5 Nm

**11 - Cap for turn signal bulb**

**12 - O-ring**

**13 - Light bulb for turn signal light HPC24WY**

- Renew ⇒ [“1.5.3 Replacing bulb for the turn signal light”, page 115](#) .

**14 - Headlight housing**

- Removing and installing ⇒ [“1.3 Removing and installing headlight”, page 111](#)
- adjust ⇒ [“1.4 Adjusting headlights”, page 113](#)

**15 - Performance module for the headlight - J668- right or -J667- left with the control unit for gas discharge lamp - J344- right or -J343- left**

- Removing and installing  
⇒ [“2.9 Remove and install performance module for the headlight J667 left or J668 right”, page 136](#)

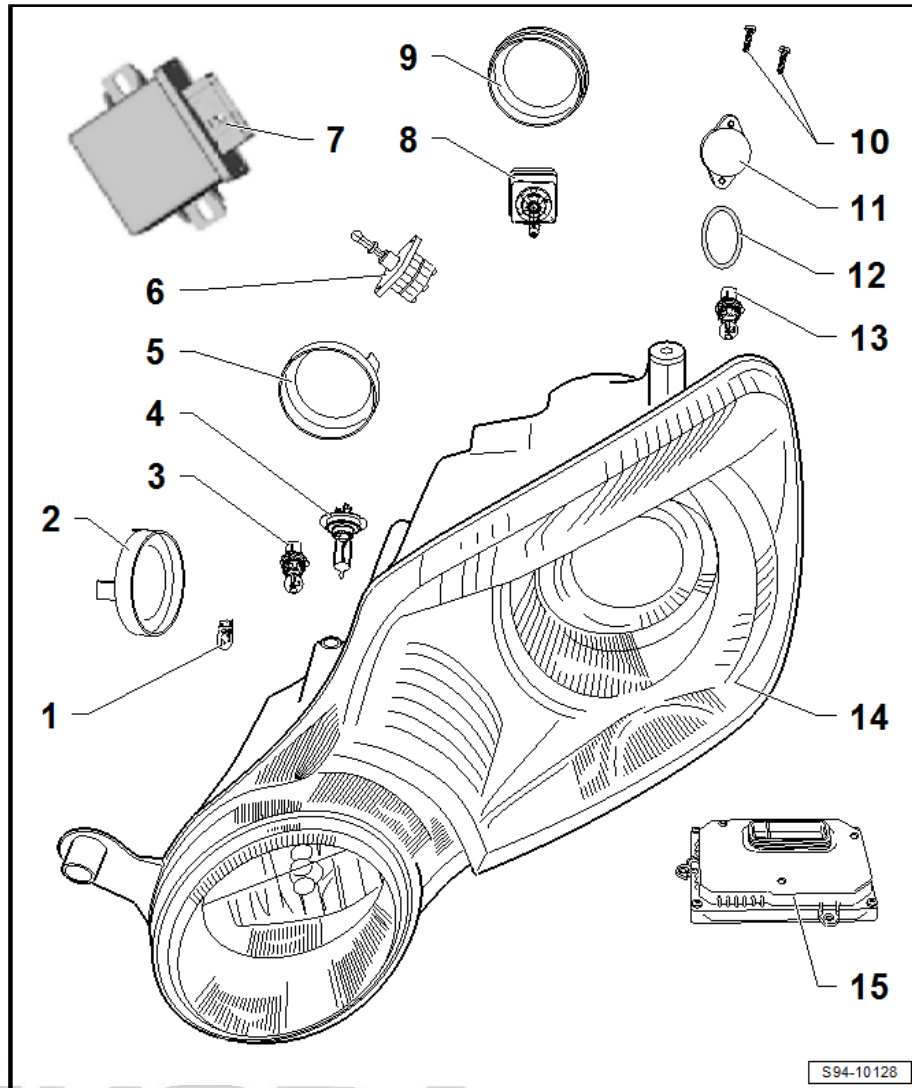

## 2.4 Summary of components headlight - vehicles as of MY 2014

### 1 - Control unit for gas discharge lamp - J343- left or - J344- right

- Removing and installing  
⇒ [“2.11 Removing and installing control unit for gas discharge lamp J343 left or J344 right”, page 138](#)

### 2 - Plastic cap

### 3 - Light bulb for main beam H7

- Renew  
⇒ [“2.8.2 Replacing bulb for main beam H7”, page 135](#) .

### 4 - Headlight housing

- Removing and installing  
⇒ [“1.3 Removing and installing headlight”, page 111](#)
- adjust  
⇒ [“1.4 Adjusting headlights”, page 113](#)

### 5 - Control motor for headlamp range control - V48- left or - V49- right

- Removing and installing  
⇒ [“2.12 Removing and installing headlight range control motor”, page 139](#)

### 6 - Gas discharge lamp with integrated high voltage ignition unit D3S

- Renew  
⇒ [“2.8.1 Replacing gas discharge lamp with integrated high voltage ignition unit D3S”, page 134](#) .

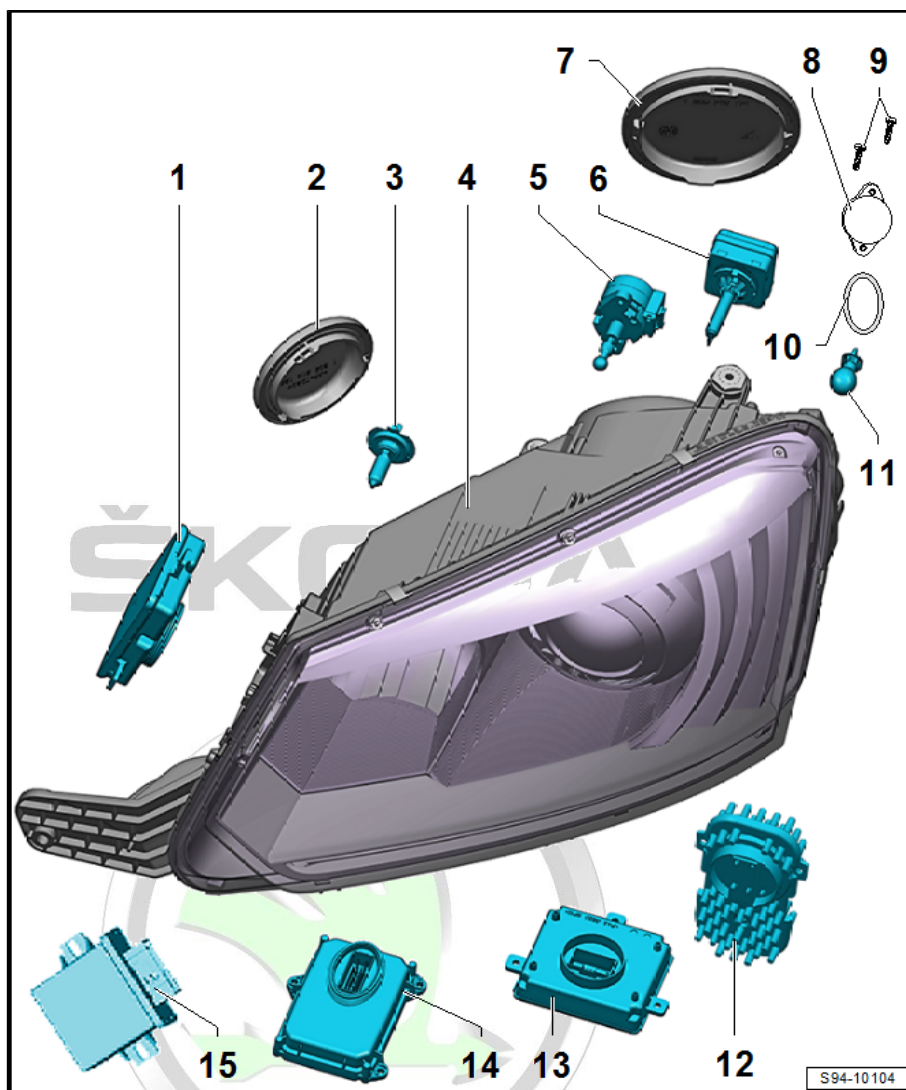

### 7 - Plastic cap

### 8 - Cap for turn signal bulb

### 9 - Bolts

- 1.5 Nm

### 10 - O-ring

### 11 - Light bulb for the turn signal light PY24W

- Renew ⇒ [“1.5.3 Replacing bulb for the turn signal light”, page 115](#) .

### 12 - Module with LED diode

- Removing and installing ⇒ [“2.8.4 Replace module with LED diodes”, page 136](#)

### 13 - Control unit for daylight driving light and side light - J860- or -J861- right

- Removing and installing  
⇒ [“2.10 Removing and installing Control unit for daylight driving light and side light left J860 and J861 right”, page 138](#)

Protected by copyright. Copying for private or commercial purposes, in part or in whole, is not permitted unless authorised by ŠKODA AUTO A. S. ŠKODA AUTO A. S. does not guarantee or accept any liability with respect to the correctness of information in this document. Copyright by ŠKODA AUTO A. S.



## 14 - Performance module for the headlight - J667- left or -J668- right

- Removing and installing  
⇒ ["2.9 Remove and install performance module for the headlight J667 left or J668 right", page 136](#)

## 15 - Cornering light and headlight range control, control unit - J745-

- behind the storage tray in the dash panel on the front passenger side
- Removing and installing  
⇒ ["2.14 Removing and installing the cornering light and headlight range control unit J745", page 141](#)

## 2.5 Removing and installing headlight

Removal and installation are identical with procedure for halogen headlights ⇒ ["1.3 Removing and installing headlight", page 111](#) .

## 2.6 Adjusting headlights

The nominal values, the work procedure and the required workshop equipment for headlight beam setting are described in the  
⇒ Repair work in the strictest sense ⇒ Maintenance ; Booklet Yeti .

## 2.7 Replacing light bulbs in the headlight - vehicles up to MY 2013

⇒ ["2.7.1 Replacing gas discharge lamp with integrated high voltage ignition unit", page 132](#)

⇒ ["2.7.2 Replacing bulb W5W BL for the parking light", page 133](#)

⇒ ["2.7.3 Replacing bulb for the turn signal light HPC24WY", page 134](#)

⇒ ["2.7.4 Replace bulb for daylight driving light", page 134](#)

### 2.7.1 Replacing gas discharge lamp with integrated high voltage ignition unit



#### WARNING

*Mortal high voltage, risk of injury and risk of pollution.*

*Observe use and safety instructions for gas discharge lamps  
⇒ Electrical System – general notes; Rep. gr. 94 .*



#### Note

- ◆ *Do not touch the glass when installing the light bulb. Your fingers will leave traces of grease on the glass which then evaporate when the bulb is switched on causing it to cloud.*
- ◆ *When installing the cover, pay attention to the correct fitting. Water ingress will destroy the headlight.*

#### Removing

- Switch off the ignition and all electrical components.
- Unplug the connector from the headlight.



- Turn cap -1- -arrow- and remove.

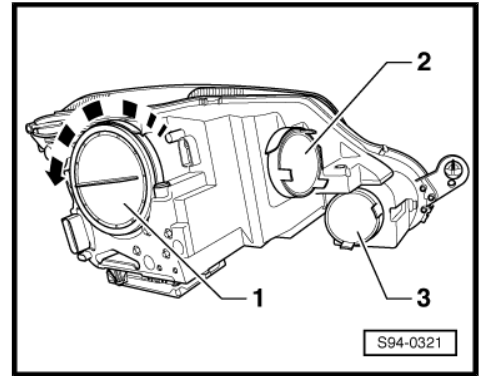

- Unplug connector -1-.
- Unclip the wire spring clamp -arrows- and carefully remove the gas discharge lamp -2-.

**Install**

Installation is performed in the reverse order, pay attention to the following points:

- Check the headlight beam setting, adjust where necessary  
 => Maintenance ; Booklet Yeti .

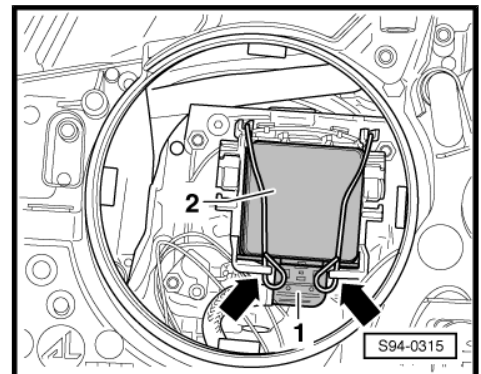

**2.7.2 Replacing bulb W5W BL for the parking light**

**i Note**

- ◆ *Do not touch the glass when installing the light bulb. Your fingers will leave traces of grease on the glass which then evaporate when the bulb is switched on causing it to cloud.*
- ◆ *When installing the cover, pay attention to the correct fitting. Water ingress will destroy the headlight.*

- Switch off the ignition and all electrical components.
- Remove rubber cap -2-.

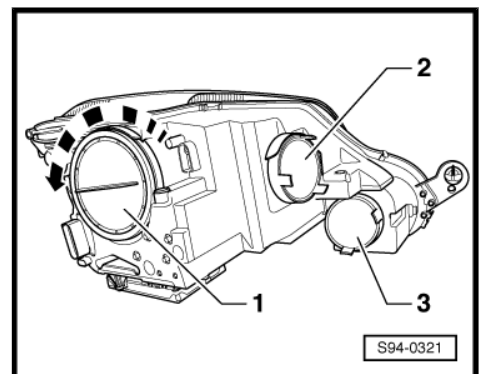
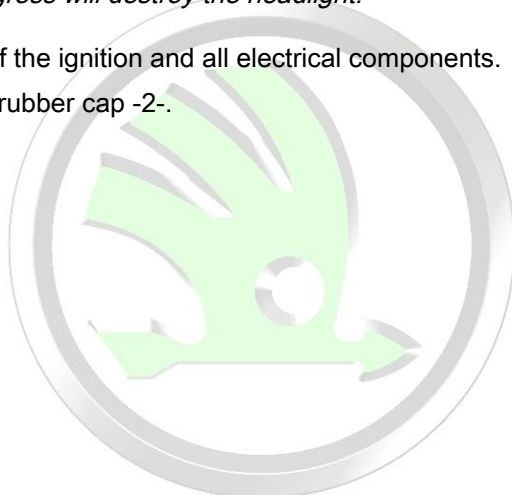

Protected by copyright. Copying for private or commercial purposes, in part or in whole, is not permitted unless authorised by ŠKODA AUTO A. S. ŠKODA AUTO A. S. does not guarantee or accept any liability with respect to the correctness of information in this document. Copyright by ŠKODA AUTO A. S. ©



- Pull connector with bulb for the parking light -1- out of the headlight -arrow-.

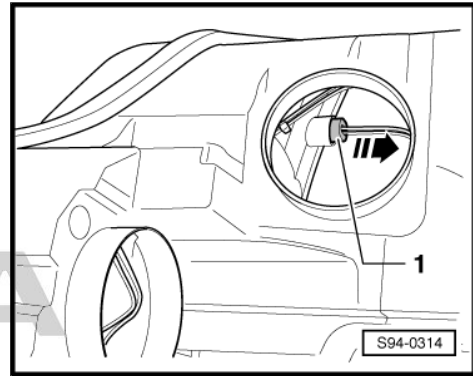

- Remove the bulb -2- from the socket -1- and replace it. Installation is carried out in the reverse order.

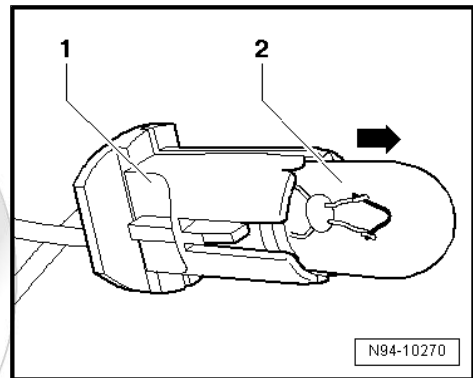

### 2.7.3 Replacing bulb for the turn signal light HPC24WY

Replacement is similar to that for halogen headlights  
 ⇒ [“1.5.3 Replacing bulb for the turn signal light”, page 115](#) .

### 2.7.4 Replace bulb for daylight driving light

Replacement is similar to that for halogen headlights  
 ⇒ [“1.5.5 Replacing bulb for daylight driving light P13W”, page 117](#) .

## 2.8 Replacing light bulbs in the headlight - vehicles as of MY 2014

⇒ [“2.8.1 Replacing gas discharge lamp with integrated high voltage ignition unit D3S”, page 134](#)

⇒ [“2.8.2 Replacing bulb for main beam H7”, page 135](#)

⇒ [“2.8.3 Replace bulb for turn signal light PWY24W”, page 136](#)

⇒ [“2.8.4 Replace module with LED diodes”, page 136](#)

### 2.8.1 Replacing gas discharge lamp with integrated high voltage ignition unit D3S



#### WARNING

*Mortal high voltage, risk of injury and risk of pollution.*

*Observe use and safety instructions for gas discharge lamps  
 ⇒ Electrical System – general notes; Rep. gr. 94 .*



**i Note**

- ◆ Do not touch the glass when installing the light bulb. Your fingers will leave traces of grease on the glass which then evaporate when the bulb is switched on causing it to cloud.
- ◆ When installing the cover, pay attention to the correct fitting. Water ingress will destroy the headlight.

**Removing**

- Switch off the ignition and all electrical components.
- Unplug the connector from the headlight.
- Turn the cover -1- towards the left and remove.

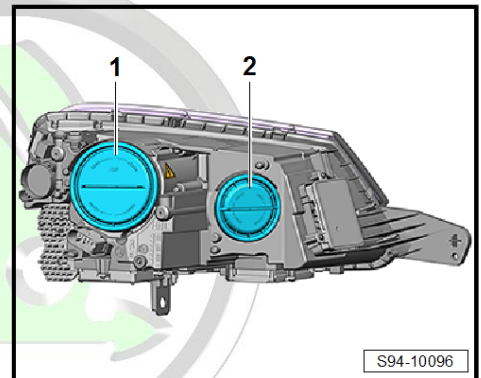

- Turn gas discharge lamp -1- and remove -arrow-.
- Unplug connector -2-.

**Install**

Installation is performed in the reverse order, pay attention to the following points:

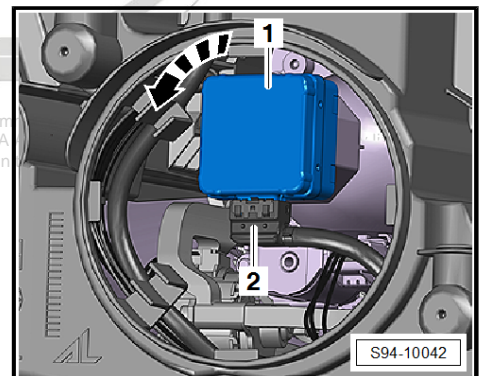

**i Note**

Check seal for damage and observe correct installation position of caps, see fig.

- Check the headlight beam setting, adjust where necessary  
 => Maintenance ; Booklet Yeti .

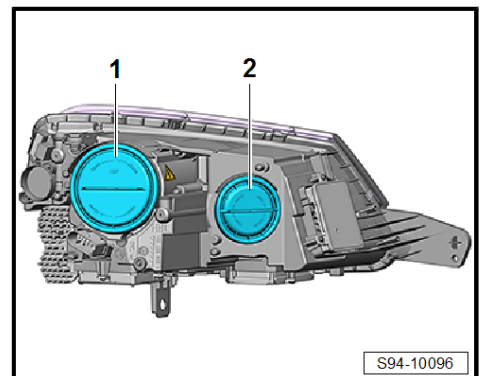

**2.8.2 Replacing bulb for main beam H7**

Replacement is similar to that for halogen headlights  
 => ["1.6.2 Replacing bulb for main beam H7", page 118](#) .



### 2.8.3 Replace bulb for turn signal light PWY24W

Replacement is similar to that for halogen headlights  
 ⇒ ["1.5.3 Replacing bulb for the turn signal light", page 115](#) .

### 2.8.4 Replace module with LED diodes



#### WARNING

*The module can be very hot, risk of burns.*

*Allows module with LED diodes to cool down before removal.*

Module with LED diodes has a daylight driving light and side light function.

- Switch off the ignition and all electrical components.
- Remove the wheelhouse liner on the side of the module to be removed ⇒ Body Work; Rep. gr. 66 .
- Unscrew screws -arrows- and carefully remove the module with LED diode -1-.
- Release connector and pull it off.

Installation is carried out in the reverse order.



#### Note

*Correctly install the seal when installing the module. Water ingress will destroy the headlight.*

Protected by copyright. Copying for private or commercial purposes, in part or in whole, is not permitted without the express authorization of ŠKODA AUTO A. S. ŠKODA AUTO A. S. does not guarantee or accept any liability for the accuracy or completeness of information in this document. Copyright by ŠKODA AUTO A. S. ©

#### Tightening torques

Fixing screws for module	1.5 Nm
--------------------------	--------

### 2.9 Remove and install performance module for the headlight - J667- left or -J668- right

⇒ ["2.9.1 Removing and installing the power module for the headlight J667 left or J668 right - vehicles up to MY 2013", page 136](#)

⇒ ["2.9.2 Removing and installing the power module for the headlight J667 left or J668 right - vehicles up to MY 2014", page 137](#)

#### 2.9.1 Removing and installing the power module for the headlight - J667- left or -J668- right - vehicles up to MY 2013

Up to MY 2013, the gas discharge (xenon) lamp control unit - J344- right/ -J343- left is a component part of the performance module for headlights.

As of MY 2014, the gas discharge (xenon) lamp control unit - J344- right or -J343- left is installed separately, see  
 ⇒ ["2.4 Summary of components headlight - vehicles as of MY 2014", page 131](#) .

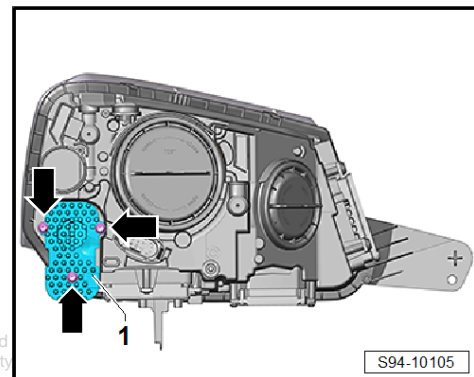

## Removing

- Remove headlight  
 ⇒ [“1.3 Removing and installing headlight”, page 111](#) .
- Unscrew the screws -2- and carefully push the power output module with the control unit -1- downwards while taking into account the connected cable length.
- Unplug connector -3-.

## Install

Installation is performed in the reverse order, pay attention to the following points:

- If the performance module with the control unit was replaced, then the coding must be carried out with ⇒ Vehicle diagnostic tester.



### Note

*Correctly install the seal when installing the control unit. Water ingress will destroy the headlight.*

- After the installation adjust the headlight  
 ⇒ [“1.4 Adjusting headlights”, page 113](#) .

## Tightening torques

Fixing screws for module	1.5 Nm
--------------------------	--------

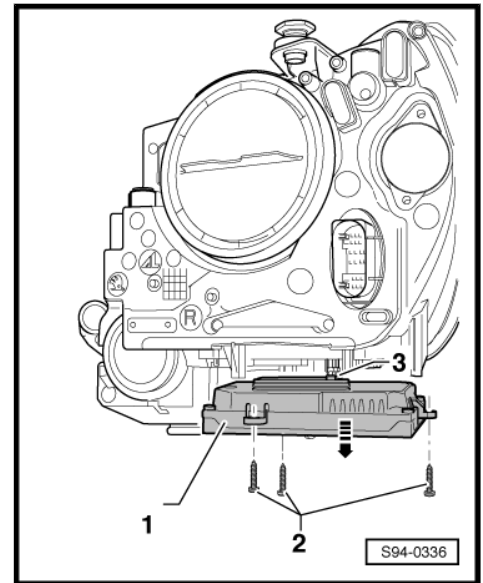

## 2.9.2 Removing and installing the power module for the headlight - J667- left or -J668- right - vehicles up to MY 2014

### Removing

- Remove headlight  
 ⇒ [“1.3 Removing and installing headlight”, page 111](#) .
- Unscrew screws -4- and carefully push the power output module -3- towards the bottom, this also disconnects the connector.

### Install

Installation is performed in the reverse order, pay attention to the following points:

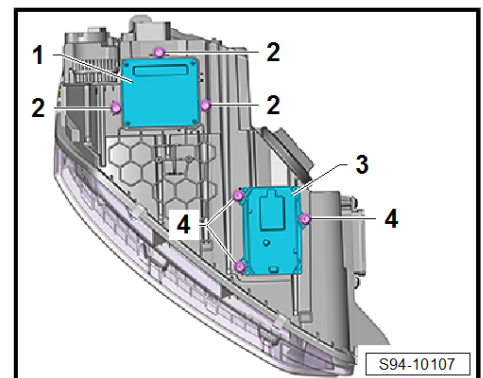
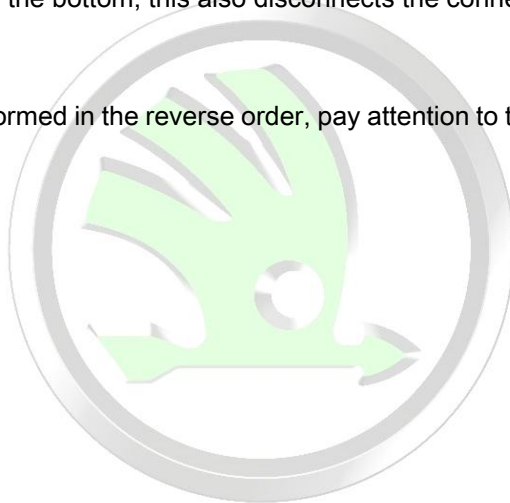



- Turn the cover -2- towards the left and remove.
- When installing the module, hold the connector in place from below.
- If the performance module was replaced, then the coding must be carried out with ⇒ Vehicle diagnostic tester.

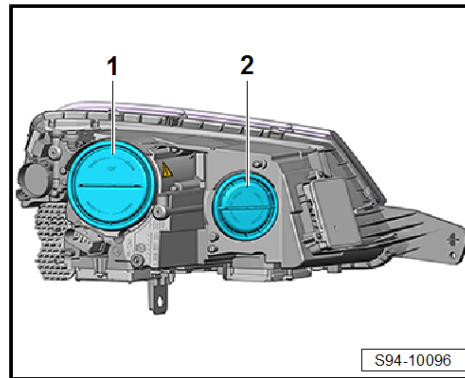

**Note**

Check seal for damage and observe correct installation position of caps, see fig.

- After the installation adjust the headlight ⇒ ["1.4 Adjusting headlights", page 113](#) .

**Tightening torques**

Fixing screws for module	1.5 Nm
--------------------------	--------

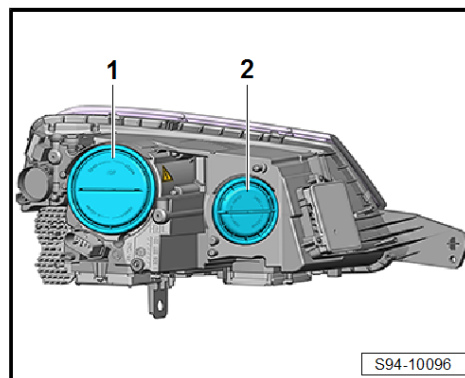

## 2.10 Removing and installing Control unit for daylight driving light and side light left - J860- and -J861- right

Installed in vehicles as of MY 2014.

**Removing**

- Remove headlight ⇒ ["1.3 Removing and installing headlight", page 111](#) .
- Unscrew screws -2- and carefully slide the control unit -1- down and out.
- Release connector and pull it off.

**Install**

Installation is performed in the reverse order, pay attention to the following points:



**Note**

Correctly install the seal when installing the control unit. Water ingress will destroy the headlight.

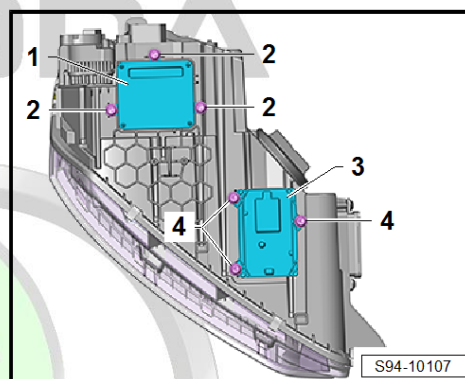

**Tightening torques**

Fixing screws for control unit	1.5 Nm
--------------------------------	--------

## 2.11 Removing and installing control unit for gas discharge lamp - J343- left or -J344- right

Installed in vehicles as of MY 2014. Protected by copyright. Copying for private or commercial purposes, in part or in whole, is not permitted unless authorised by ŠKODA AUTO A. S. ŠKODA AUTO A. S. does not guarantee or accept any liability with respect to the correctness of information in this document. Copyright by ŠKODA AUTO A. S. ©



## Removing

- Remove headlight  
 ⇒ [“1.3 Removing and installing headlight”, page 111](#) .
- Unscrew the screws -arrows- and carefully remove the control unit -1-.
- Release connector and pull it off.

## Install

Installation is performed in the reverse order, pay attention to the following points:



### Note

*Correctly install the seal when installing the control unit. Water ingress will destroy the headlight.*

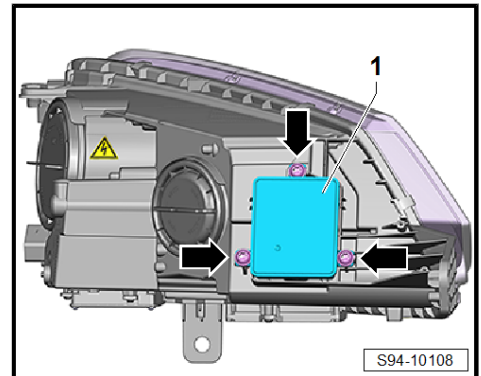

## Tightening torques

Fixing screws for control unit	1.5 Nm
--------------------------------	--------

## 2.12 Removing and installing headlight range control motor

⇒ [“2.12.1 Removing and installing headlight range control motor - vehicles up to MY 2013”, page 139](#)

⇒ [“2.12.2 Removing and installing headlight range control motor - vehicles as of MY 2014”, page 140](#)

### 2.12.1 Removing and installing headlight range control motor - vehicles up to MY 2013

#### Removing

- Remove headlight with defective control motor  
 ⇒ [“1.3 Removing and installing headlight”, page 111](#) .
- Remove cover -1- and -2- (cover -2- when removing the control motor for purposes of presentation).
- In order to facilitate access to the control motor, remove the gas discharge lamp and its holder  
 ⇒ [“2.7 Replacing light bulbs in the headlight - vehicles up to MY 2013”, page 132](#) .

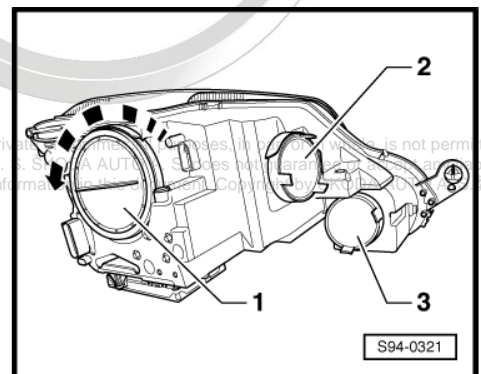



- Carefully break out the plugs -1- (they must not fall into the headlight housing) and unscrew the fixing screws of the control motor -2-.

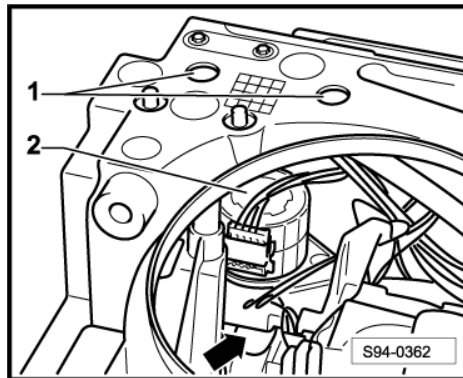

- Unhook the pressure element -1- -arrow-.
- Remove the control motor and disconnect the plug.

**Install**

Installation is performed in the reverse order, pay attention to the following points:

- Replace the broken out plugs with the plugs from the repair kit.
- When installing the caps, pay attention to the correct fitting. Water ingress will destroy the headlight.
- Inspect proper operation.
- Set up the headlight ⇒ Maintenance ; Booklet Yeti .

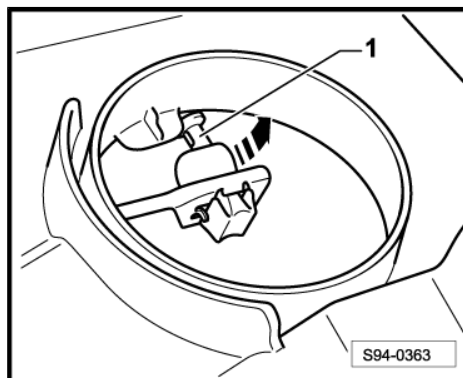

**2.12.2 Removing and installing headlight range control motor - vehicles as of MY 2014**

**Removing**

- Remove headlight  
⇒ ["1.3 Removing and installing headlight", page 111](#) .
- Turn cover -1- towards the left and remove, and also remove the cover -2- during the work for the purpose of clear presentation.
- Remove the gas discharge lamp  
⇒ ["2.8.1 Replacing gas discharge lamp with integrated high voltage ignition unit D3S", page 134](#) .

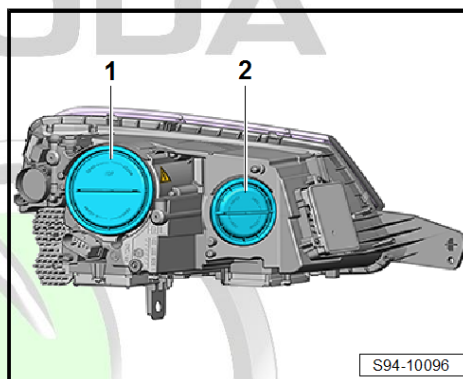

Protected by copyright. Copying for private or commercial purposes, in part or in whole, is not permitted unless authorised by ŠKODA AUTO A. S. ŠKODA AUTO A. S. does not guarantee or accept any liability with respect to the correctness of information in this document. Copyright by ŠKODA AUTO A. S. ©



- Carefully brake out plugs -3- via the fixing screws of the control motor (they must not be allowed to fall into the headlight housing).
- Unscrew screws -1-.
- Unhook the pressure element of the control motor out of the bearing -arrow-.
- Remove the control motor -2- and disconnect the plug -4-.

#### Install

Installation is performed in the reverse order, pay attention to the following points:

- Replace the broken out plugs with the plugs from the repair kit.

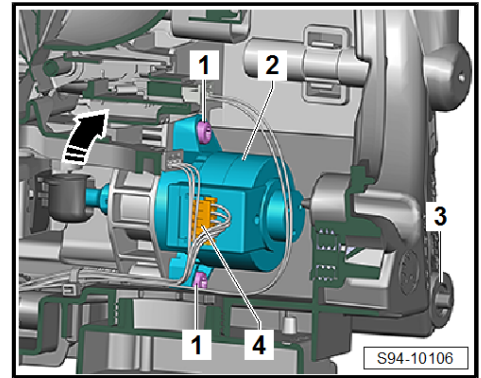

#### Note

*Check seal for damage and observe correct installation position of caps, see fig.*

- Inspect proper operation.
- Set up the headlight ⇒ Maintenance ; Booklet Yeti .

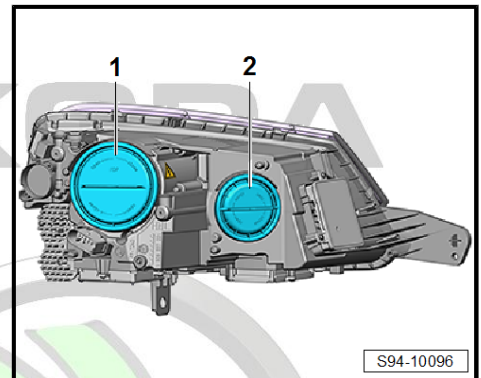

## 2.13 Change headlight for right-hand / left-hand traffic

The position of the ray of light should be adjusted when driving in countries which drive on the right or the left thereby preventing blinding of the drivers travelling in the opposite direction.

On vehicles which have the Maxi DOT display in the dash panel insert, the position of the ray of light in the menu "Maxi DOT" function "light and sight - travel mode - right-hand drive or left-hand drive" can be adjusted see ⇒ Owner's manual Yeti .

If the dash panel insert is not equipped with the Maxi DOT display, the position of the ray of light must be adjusted with ⇒ Vehicle diagnostic tester.

## 2.14 Removing and installing the cornering light and headlight range control unit - J745-

- Switch off all electrical components and take out the ignition key.

#### Remove - right-hand drive

- Remove the storage compartment in the dash panel on the front passenger side ⇒ Body Work; Rep. gr. 70 .

Protected by copyright. Copying for private or commercial purposes, in part or in whole, is not permitted unless authorised by ŠKODA AUTO A. S. ŠKODA AUTO A. S. does not guarantee or accept any liability with respect to the correctness of information in this document. Copyright by ŠKODA AUTO A. S. ©



- Unscrew fixing screws -1-.
- Carefully unhook the control unit -3- a little towards the bottom and disconnect the plug -2- by tilting out the catch clamp.

**Remove - left-hand drive**

- Remove the storage compartment in the dash panel on the front passenger side ⇒ Body Work; Rep. gr. 70 .
- Unscrew the bottom fixing screws in the dash panel on the front passenger side and slightly tilt out the bottom part of the dash panel on the front passenger side towards you.

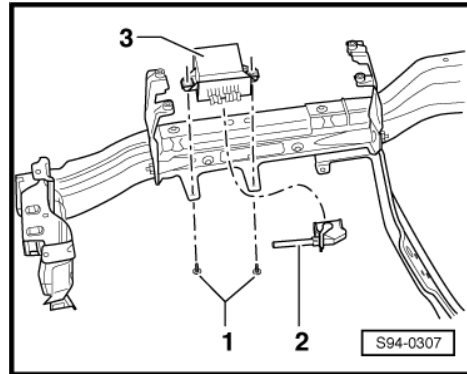

- Unscrew screws -1- and detach the control unit -2- from the bracket.
- Disconnect the plug by tilting out the catch clamp -3-.

**Install**

Installation is performed in the reverse order, pay attention to the following points:

- If the control unit was replaced, then the coding of the new control unit must be carried out with the ⇒ Vehicle diagnostic tester in the function “Targeted fault finding”.
- Subsequently carry out the basic setting of the headlight ⇒ [“1.4 Adjusting headlights”, page 113](#) .

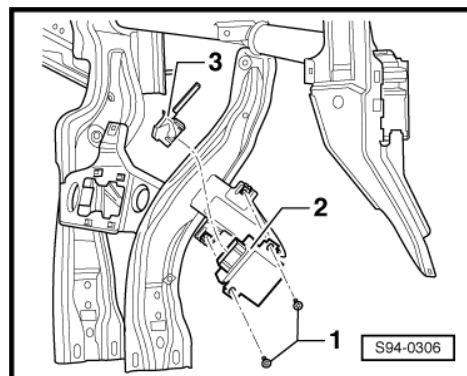

**Tightening torques**

Fixing screws for control unit	1.5 Nm
--------------------------------	--------

**2.15 Vehicle level sensor front left -G78- and rear left -G76-**



**Note**

- ◆ *Front vehicle level sensor - G78- only for vehicles manufactured up to CW 45.2009.*
- ◆ *If the sender at the front axle is defective, detach the sender (do not replace) and change the code of the control unit with ⇒ Vehicle diagnostic tester.*

The vehicle level sensors are an integral part of the headlight range.

The assembly work is described in the Workshop Manual ⇒ Chassis :

- ◆ Install front left vehicle level sensor - G78- ⇒ Chassis; Rep. gr. 40
- ◆ Install rear left vehicle level sensor - G76- ⇒ Chassis; Rep. gr. 42

**2.16 Replace headlight fixing brackets**

Replacement of the headlight attachment brackets is similar to that for the halogen headlight ⇒ [“1.8 Replace headlight fixing brackets”, page 124](#) .

Protected by copyright. Copying for private or commercial purposes, in part or in whole, is not permitted unless authorised by ŠKODA AUTO A. S. ŠKODA AUTO A. S. does not guarantee or accept any liability with respect to the correctness of information in this document. Copyright by ŠKODA AUTO A. S. ©



### 3 Fog light with corner function - as of MY 2014

⇒ ["3.1 Removing and installing fog light", page 143](#)

⇒ ["3.2 Replacing the light bulb for fog light H8", page 144](#)

⇒ ["3.3 Adjusting the fog light", page 145](#)

#### 3.1 Removing and installing fog light

##### Removing

- Switch off the ignition and all electrical components.
- Carefully prise out covers -1- out of the catches -arrows- in succession.

Outdoor model

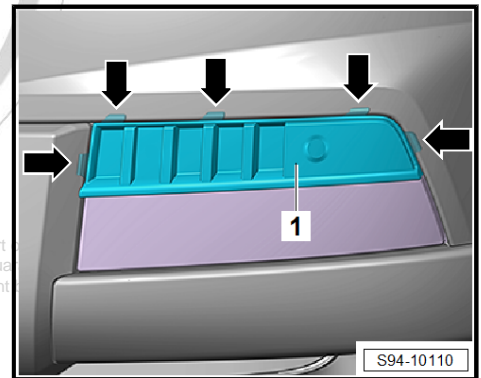

Protected by copyright. Copying for private or commercial purposes, in part or in full, is prohibited unless authorised by ŠKODA AUTO A. S. ŠKODA AUTO A. S. does not guarantee the correctness of information in this document. Copyright © 2016 ŠKODA AUTO A. S.

City model

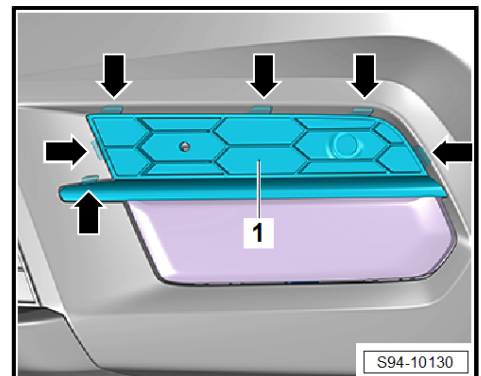



- Unscrew screws -1-, raise headlight -2- and remove -arrow-.
- Disconnect plug.

### Install

Installation is carried out in the reverse order.



#### Note

- ◆ Two ventilation angled pieces are located on the reverse side of the fog light.
- ◆ The ventilation angled piece is always delivered as one piece in the spare part with the dust filter.
- ◆ If a new ventilation angled piece is built into the “City” model, this dust filter (due to the fog light having a different type) must be removed from the ventilation angled piece.

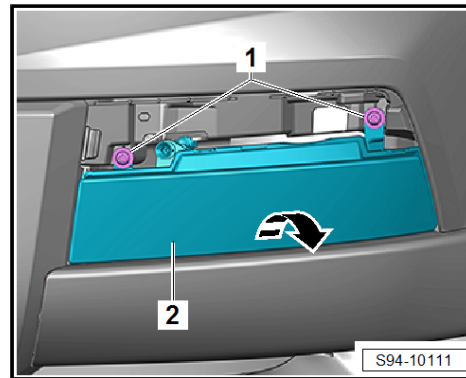

### Tightening torques

Fixing screws for fog lights	1.5 Nm
------------------------------	--------

## 3.2 Replacing the light bulb for fog light “H8”



#### Note

Do not touch the glass when installing the light bulb. Your fingers will leave traces of grease on the glass which then evaporate when the bulb is switched on causing it to cloud.



#### WARNING

**The H8 light bulb is pressurized and can burst when changing the bulb. It is recommended to wear gloves and safety glasses when changing bulbs.**

- Remove fog light  
⇒ [“3.1 Removing and installing fog light”, page 143](#).
- Turn the light bulb with socket -arrow- and remove.
- Replace defective light bulb.

Installation is carried out in the reverse order.

- Check the headlight beam setting, adjust where necessary  
⇒ Maintenance ; Booklet Yeti

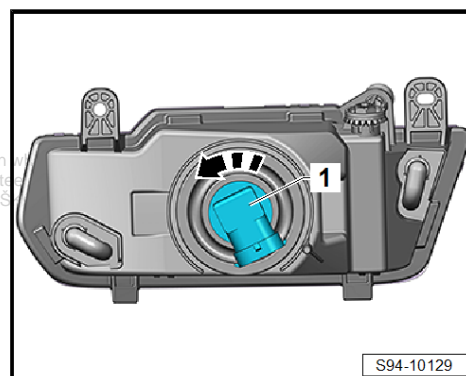



### 3.3 Adjusting the fog light



*Use a headlight beam setting device for setting the headlight beam. The nominal values and the adjustment procedure can be found in the Manual ⇒ Maintenance ; Booklet Yeti .*

# ŠKODA



Protected by copyright. Copying for private or commercial purposes, in part or in whole, is not permitted unless authorised by ŠKODA AUTO A. S. ŠKODA AUTO A. S. does not guarantee or accept any liability with respect to the correctness of information in this document. Copyright by ŠKODA AUTO A. S. ©

## 4 Tail lights

⇒ [“4.1 Removing and installing the tail light”, page 146](#)

⇒ [“4.2 Removing and installing lamp holder”, page 146](#)

⇒ [“4.3 Summary of components of light bulbs”, page 147](#)

### 4.1 Removing and installing the tail light

#### Removing

- Switch off the ignition and all electrical components.
- Unscrew the screws -1- and release the light -2- towards the rear -arrow- out of the retaining parts -3-.
- Unplug connector -4-.

#### Install

Installation is carried out in the reverse order.

#### Tightening torques

Fixing screws for light	2.5 Nm
-------------------------	--------

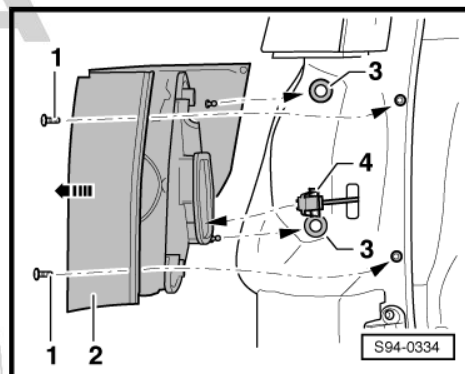

### 4.2 Removing and installing lamp holder

#### Removing

- Remove tail light  
⇒ [“4.1 Removing and installing the tail light”, page 146](#).
- Unscrew bolt -2-.

#### Variant without LED diodes

Protected by copyright. Copying for private or commercial purposes, in part or in whole, is not permitted without the prior written consent of ŠKODA AUTO A. S. ŠKODA AUTO A. S. does not guarantee or accept any liability for the accuracy or completeness of the information in this document. Copyright by ŠKODA AUTO A. S.

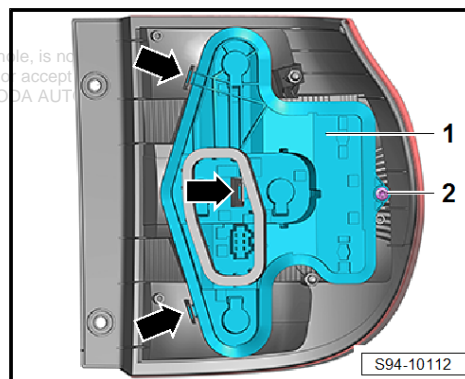

#### Variant with LED diodes

- Unclip lamp holder -1- -arrows- and remove it.

#### Install

Installation is carried out in the reverse order.

#### Tightening torques

Fixing screws for bulb carrier	1.2 Nm
--------------------------------	--------

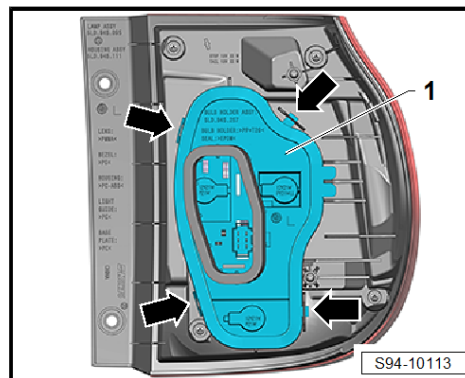

## 4.3 Summary of components of light bulbs

### Variant without LED diodes

- 1 - Brake light - P21W
- 2 - Parking light - W5W
- 3 - Turn signal light - PY21W
- 4 - Parking light - W5W
- 5 - Fog light - P21W
- 6 - Reversing light - P21W

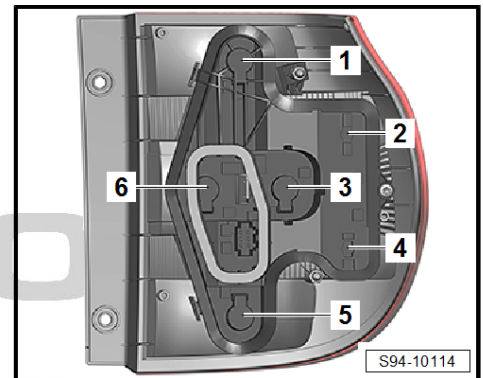

### Variant with LED diodes

- 1 - Reversing light - P21W
- 2 - Turn signal light - PY21W
- 3 - Fog light - P21W



*LED diodes have a brake light and parking light function and are integrated in the lamp housing. Not replaceable individually.*

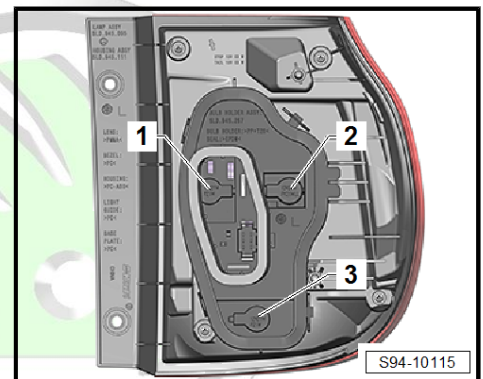

Protected by copyright. Copying for private or commercial purposes, in part or in whole, is not permitted unless authorised by ŠKODA AUTO A. S. ŠKODA AUTO A. S. does not guarantee or accept any liability with respect to the correctness of information in this document. Copyright by ŠKODA AUTO A. S.



## 5 Number plate light

⇒ "5.1 Removing and installing number plate light", page 148

### 5.1 Removing and installing number plate light



#### Note

*Lighting variant with LED diode - In the event of a defect, replace the entire lighting.*

- Switch off the ignition and all electrical components.

#### Removing - secured with screws

- Uniformly unscrew the fixing screws -arrows- in the light emission window.

#### Removing - secured with catches

- Insert a small cross-head screwdriver -2- into the hole of the lamp, see fig.
- Slightly move the light -1- e.g. with a screwdriver -2- in direction of arrow -A- and tilt out in direction of arrow -B-.

#### All vehicles

- Remove the light.
- Disconnect plug.
- Replace any faulty bulbs (by type, bulb C5W/W5W).

#### Install

Installation is performed in the reverse order, pay attention to the following points:

#### Tightening torques

Fixing screws for light	0.5 Nm
-------------------------	--------

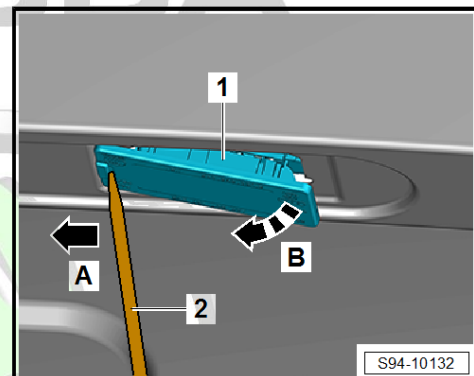
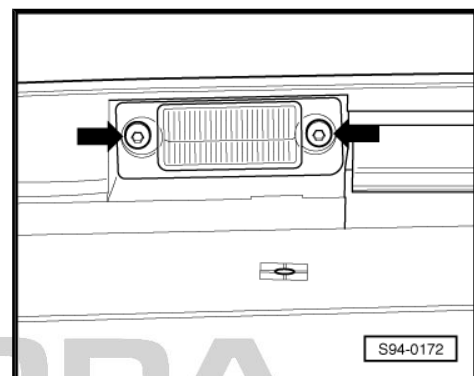

## 6 High level brake light

⇒ "6.1 Removing and installing high level brake light", page 149

### 6.1 Removing and installing high level brake light

#### Removing

- Switch off the ignition and all electrical components.
- Remove the top tailgate trim panel ⇒ Body Work; Rep. gr. 70 .
- Press the retaining tabs -arrows- and slacken the high level brake light from the tailgate.
- Disconnect plug.

#### Install



#### Note

- ◆ *The high level brake light is fitted with diodes which cannot be replaced individually.*
- ◆ *Check all the way around the seal for damage.*
- Connect the plug to the brake light and insert the light into the assembly opening in the tailgate.
- Insert a small screwdriver consecutively into the openings -arrows- and pull it across until the retaining tabs click audibly into place.

Protected by copyright. Copying for private or commercial purposes, in part or in whole, is not permitted unless authorised by ŠKODA AUTO A. S. ŠKODA AUTO A. S. does not guarantee or accept any liability with respect to the correctness of information in this document. Copyright by ŠKODA AUTO A. S.

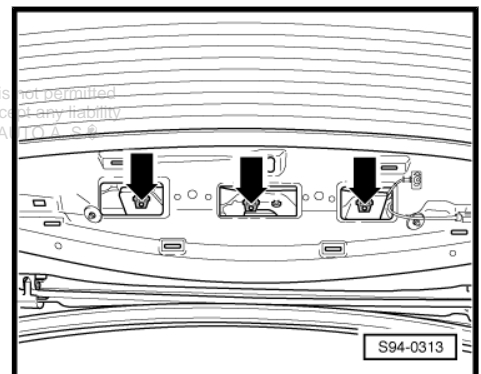
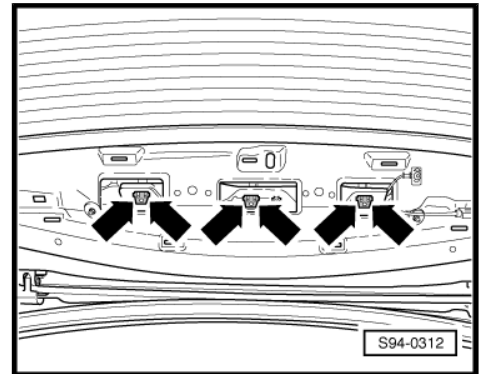



## 7 Steering column switch

⇒ [“7.1 Self-diagnosis, coding and fault indication”, page 150](#)

⇒ [“7.2 Steering column switch - installed up to 05.2010”, page 150](#)

⇒ [“7.3 Steering column switch - installed as of 06.2010”, page 156](#)

⇒ [“7.4 Setting middle position of the return ring with coil spring”, page 159](#)

### 7.1 Self-diagnosis, coding and fault indication

In case of malfunctions of the steering column switch, check the coding.

The steering column electronics control unit - J527- is equipped with self-diagnosis, which facilitates the fault finding.

Use the ⇒ Vehicle diagnostic tester for troubleshooting and coding.

### 7.2 Steering column switch - installed up to 05.2010

⇒ [“7.2.1 Summary of components of steering column switch”, page 150](#)

⇒ [“7.2.2 Removing and installing steering column electronics control unit J527 ”, page 151](#)

⇒ [“7.2.3 Removing and installing switch mounting on the steering column”, page 152](#)

⇒ [“7.2.4 Removing and installing return ring with coil spring F350 ”, page 154](#)

⇒ [“7.2.5 Removing and installing lever key of switch mounting on the steering column”, page 154](#)

⇒ [“7.2.6 Contact assignment on the steering column electronics control unit J527 ”, page 155](#)

#### 7.2.1 Summary of components of steering column switch

Protected by copyright. Copying for private or commercial purposes, in part or in whole, is not permitted unless authorised by ŠKODA AUTO A. S. ŠKODA AUTO A. S. does not guarantee or accept any liability

document. Copyright by ŠKODA AUTO A. S.

### 1 - Left lever key

- ◆ Removing and installing  
⇒ [“7.2.5 Removing and installing lever key of switch mounting on the steering column”, page 154](#)

### 2 - Switch mounting on the steering column

- ◆ Removing and installing  
⇒ [“7.2.3 Removing and installing switch mounting on the steering column”, page 152](#)

### 3 - Right lever key

- ◆ Removing and installing  
⇒ [“7.2.5 Removing and installing lever key of switch mounting on the steering column”, page 154](#)

### 4 - Fixing screw

- 0.4 Nm

### 5 - Steering column electronics control unit - J527-

- ◆ Removing and installing  
⇒ [“7.2.2 Removing and installing steering column electronics control unit J527”, page 151](#)

### 6 - Return ring with coil spring - F350-

- ◆ Removing and installing  
⇒ [“7.2.4 Removing and installing return ring with coil spring F350”, page 154](#)

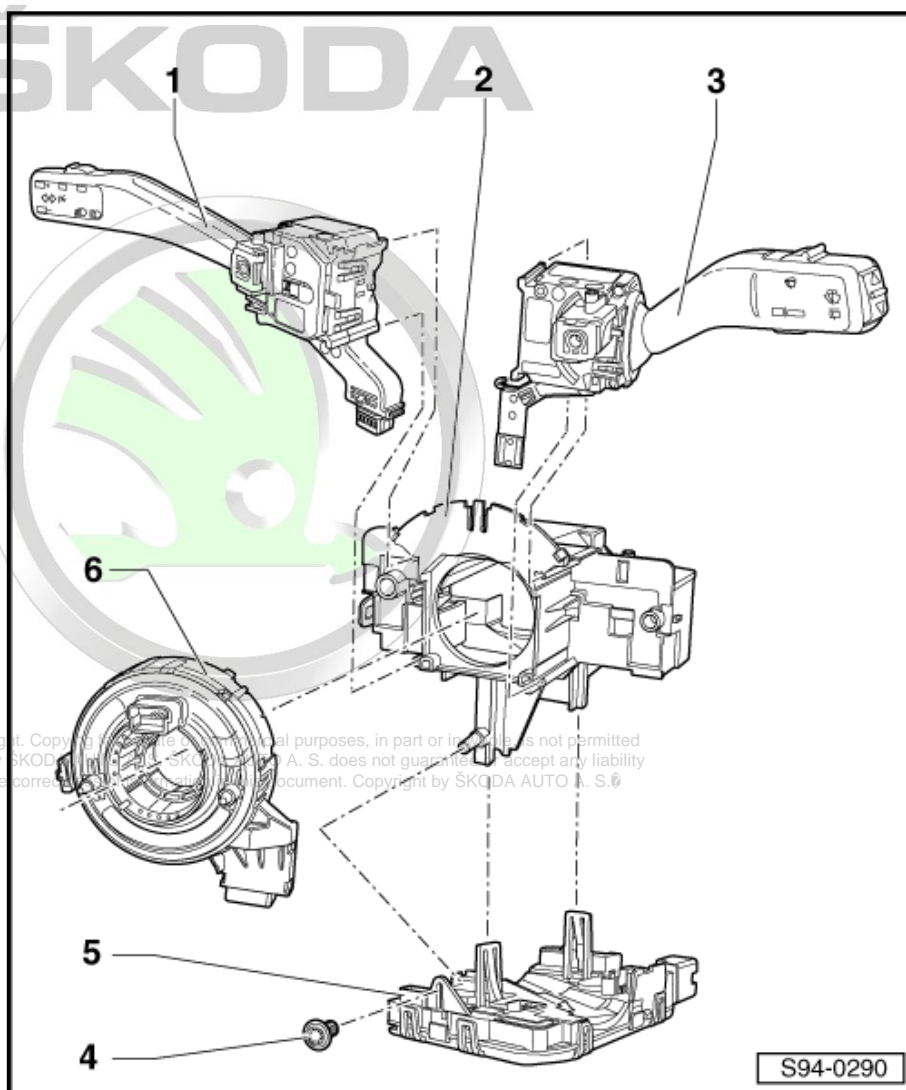

## 7.2.2 Removing and installing steering column electronics control unit - J527-



### Note

The new control unit must be coded after the installation see  
⇒ [Vehicle diagnostic tester](#).

### Special tools and workshop equipment required

- ◆ Drill Ø 2.5 mm

### Removing

- Remove steering wheel ⇒ [Body Work; Rep. gr. 69](#) .
- Removing top and bottom steering column trim ⇒ [Body Work; Rep. gr. 70](#) .



- Unscrew bolt -1-.
- Insert in the opening arrow -1- the drill -2- (Ø 2.5 mm)
- Unlatch the fuse in direction of arrow -2- using the drill.

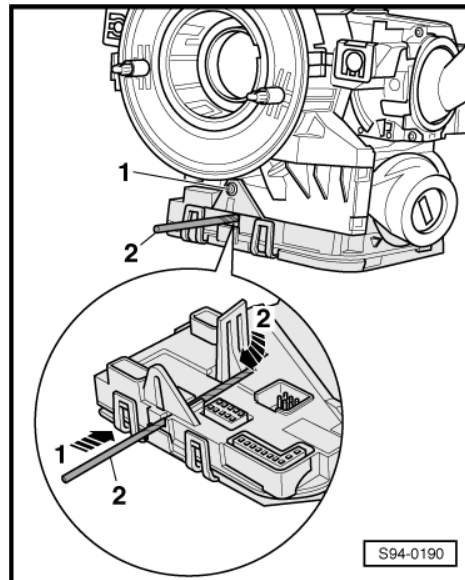

- Press fuse on the connector side with a suitable screwdriver in -direction of arrow-, in order to unlatch it.
- Carefully pull off control unit from the switches straight to the bottom in such a way that it does not tilt.

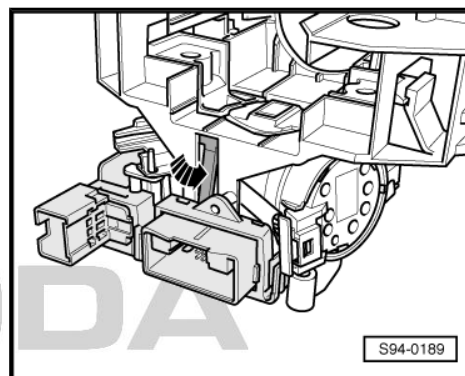

- Unlock the plug connection -1- and disconnect -A-.
- Pull lock -3- out of the plug connection -2-, press fuse -arrow- and disconnect plug connection.

**Install**

Installation is performed in the reverse order, pay attention to the following points:

- Make sure that all the retaining lugs and plug connections lock in place correctly.

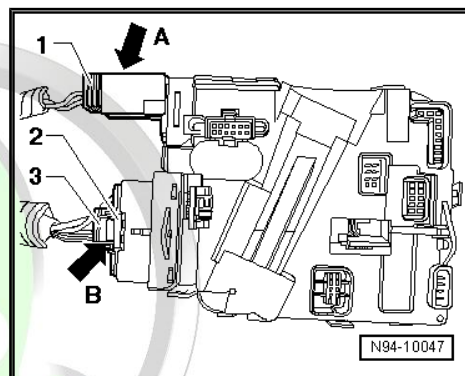

**Tightening torques**

Fixing screws for control unit	0.4 Nm
--------------------------------	--------

**7.2.3 Removing and installing switch mounting on the steering column**



**Note**

Protected by copyright. Copying for private or commercial purposes, in part or in whole, is not permitted unless authorised by ŠKODA AUTO A. S. ŠKODA AUTO A. S. does not guarantee or accept any liability with respect to the correctness of information in this document. Copyright by ŠKODA AUTO A. S. ©

*The fixing screws of the steering lock must be bored out in order to remove the switch mounting on the steering column. New pull-off screws are required for later installation => Electronic Catalogue of Original Parts .*



**Caution**

*When boring out the screws splinters can penetrate into the surrounding components and can cause damage and/or functional problems. Thus it is purposeful to remove these components before boring out the screws.*

**Removing**

Remove the following components consecutively as follows:

- Steering column electronics control unit - J527-  
 => "7.2.2 Removing and installing steering column electronics control unit J527", page 151 .
- Return ring with coil spring - F350-  
 => "7.2.4 Removing and installing return ring with coil spring F350", page 154 .
- Left and right lever key  
 => "7.2.5 Removing and installing lever key of switch mounting on the steering column", page 154 .
- Disconnect plug connection from the reader coil -arrow-.
- Bore out fixing screws -1- for steering lock with lock cylinder and ignition lock -3-.
- Slide switch mounting -2- with steering lock out of the steering column.

- Release the retaining lugs -arrows- and remove the steering lock housing -2- from the mounting -1-.

**Install**

Protected by copyright. Copying for private or commercial purposes, in part or in whole, is not permitted unless authorised by ŠKODA AUTO A. S. ŠKODA AUTO A. S. does not guarantee or accept any liability with respect to the correctness of information in this document. Copyright by ŠKODA AUTO A. S.

- Insert steering lock with lock cylinder and ignition lock -3- into the switch mounting -2-.
- Fit switch mounting with steering lock as far as possible onto the steering column.
- Insert plug connection -arrow- into the reader coil at the lock cylinder.
- Screw on steering lock with new pull-off screws -1- and tighten until the screw heads are torn off.
- Install the other components in reverse order.

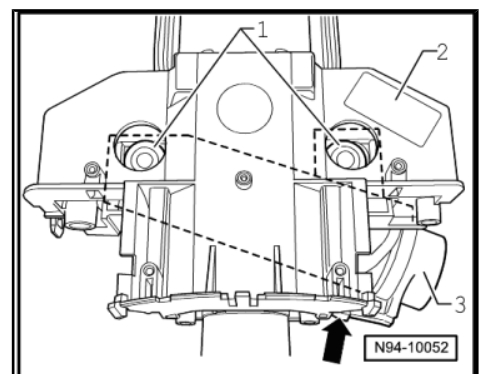
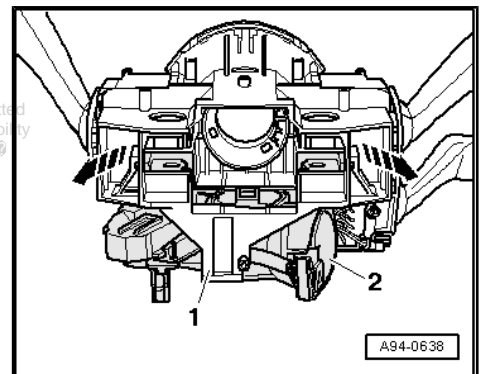
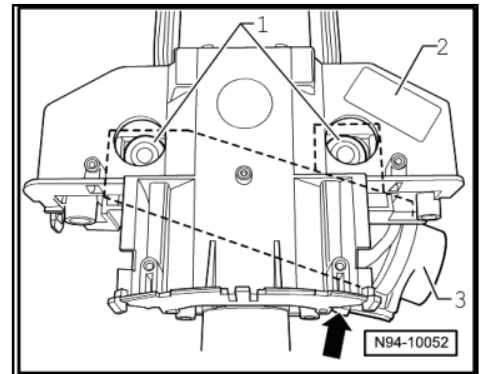



## 7.2.4 Removing and installing return ring with coil spring - F350-

### Removing

- Removing steering column electronics control unit - J527-  
⇒ [“7.2.2 Removing and installing steering column electronics control unit J527”, page 151](#) .
- Carefully release retaining tabs -arrows- and pull off return ring with coil spring -1- from the switch mounting on the steering column.

### Install

Installation is performed in the reverse order, pay attention to the following points:



#### Note

*When installing, the return ring with coil spring must be in the middle position and the wheels in the straight ahead position. In case of doubt about the correct positioning of the ring rotor, the middle position of the return ring must be set before installing the steering wheel*  
⇒ [“7.4 Setting middle position of the return ring with coil spring”, page 159](#) .

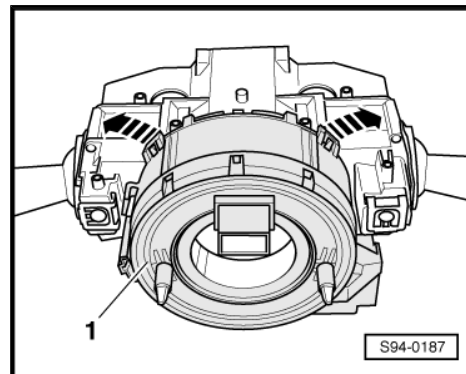

## 7.2.5 Removing and installing lever key of switch mounting on the steering column

### Special tools and workshop equipment required

- ◆ Feeler gauge

### Removing

- Remove return ring with coil spring  
⇒ [“7.2.4 Removing and installing return ring with coil spring F350”, page 154](#) .



#### Note

*The following operations are shown on a removed steering column switch for purposes of clear presentation.*

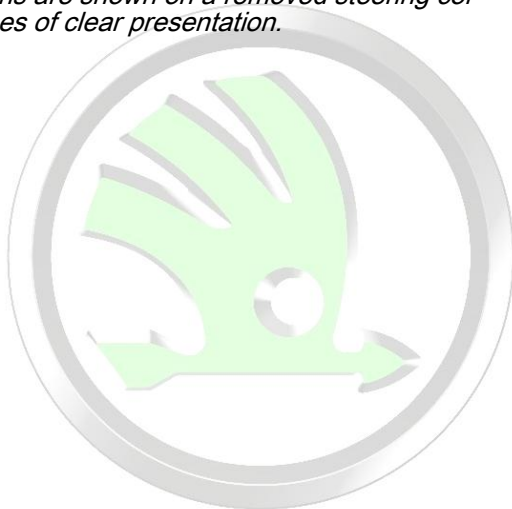



- Unlock the retaining lugs -arrows- with feeler gauge 1.0 mm-1- and remove the left level key in the direction of arrow -A-.

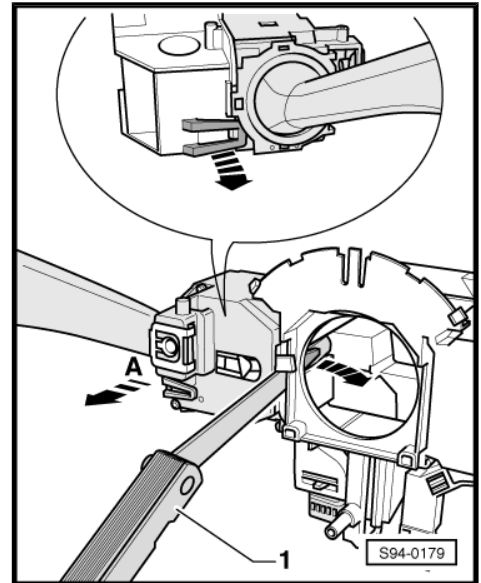

- Unlock the retaining lugs -arrows- with feeler gauge 1.0 mm -1- and remove the right level key in the direction of arrow -A-.

#### Install

Installation is performed in the reverse order, pay attention to the following points:

- Make sure that all the retaining lugs lock in place correctly.

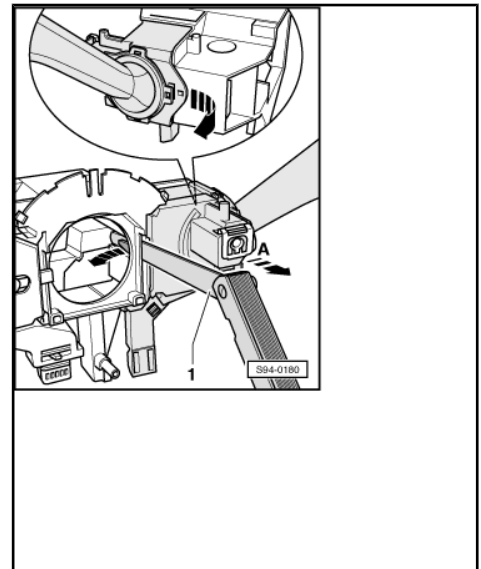

### 7.2.6 Contact assignment on the steering column electronics control unit - J527-

The contact assignment on the steering column electronics control unit - J527- can be found in the Workshop Manual ⇒ Current flow diagrams, Electrical fault finding and Fitting locations.



## 7.3 Steering column switch - installed as of 06.2010

⇒ [“7.3.1 Summary of components of steering column switch with mechanical steering lock”, page 156](#)

⇒ [“7.3.2 Summary of components of steering column switch with electronic steering lock”, page 157](#)

⇒ [“7.3.3 Removing and installing return ring with coil spring F350 with integrated steering column electronics control unit J527”, page 158](#)

⇒ [“7.3.4 Removing and installing steering column combination switch”, page 159](#)

⇒ [“7.3.5 Contact assignment on the steering column electronics control unit J527”, page 159](#)

### 7.3.1 Summary of components of steering column switch with mechanical steering lock

The steering column electronics control unit - J527- , steering column combination switch - E595- and base holder for steering column switch components are designed according to the manufacturer (Valeo or Kostal). The summary of components illustration shows the Valeo manufacturer's design.

**1 - Return ring with coil spring - F350- with integrated steering column electronics control unit - J527-**

- ◆ Removing and installing  
⇒ [“7.3.3 Removing and installing return ring with coil spring F350 with integrated steering column electronics control unit J527”, page 158](#)

**2 - Steering column combination switch**

- ◆ Removing and installing  
⇒ [“7.3.4 Removing and installing steering column combination switch”, page 159](#)

**3 - Switch carrier on the steering column**

- Removing and installing  
⇒ [“8.3 Removing and installing steering lock - installed as of 06.2010”, page 163](#)

**4 - Pull-off screws**

- Breakaway torque approx. 15 Nm

**5 - Steering lock housing**

- Removing and installing  
⇒ [“8.3 Removing and installing steering lock - installed as of 06.2010”, page 163](#)

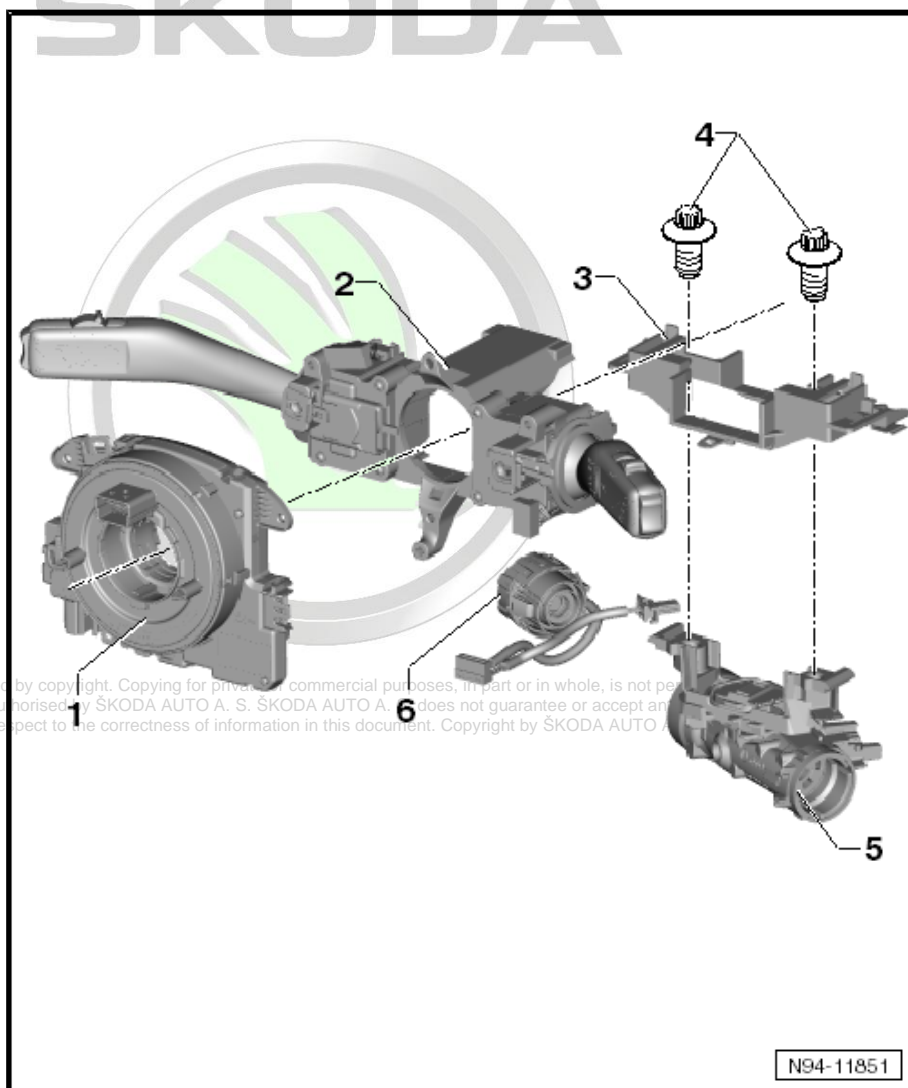

N94-11851

## 6 - Ignition/starter switch

- ❑ Removing and installing ⇒ [“8.4 Removing and installing the ignition/starter switch”, page 163](#)

## 7.3.2 Summary of components of steering column switch with electronic steering lock

### Note

- ◆ Installed as of MY 2014 in vehicles with interface for entry and start system.
- ◆ The steering column electronics control unit - J527-, steering column combination switch - E595- and base holder for steering column switch components are designed according to the manufacturer (Valeo or Kostal). The summary of components illustration shows the Valeo manufacturer's design.

### 1 - Return ring with coil spring - F350- with integrated steering column electronics control unit - J527-

- ◆ Removing and installing ⇒ [“7.3.3 Removing and installing return ring with coil spring F350 with integrated steering column electronics control unit J527”, page 158](#)

### 2 - Steering column combination switch

- ◆ Removing and installing ⇒ [“7.3.4 Removing and installing steering column combination switch”, page 159](#)

### 3 - Switch carrier on the steering column

- ❑ Removing and installing is identical to that of the steering lock housing ⇒ [“9.7.2 Removing and installing steering lock with control unit for ELV J764”, page 172](#)

### 4 - Pull-off screws

- ❑ M 8 × 20
- ❑ Breakaway torque approx. 15 Nm

### 5 - Steering lock with control unit for electronic steering column lock - J764- (ESCL)

- ◆ Removing and installing ⇒ [“9.7.2 Removing and installing steering lock with control unit for ELV J764”, page 172](#)

### 6 - Start/stop button - E378-

- ❑ with immobiliser reader coil for emergency start
- ❑ Removing and installing ⇒ [“9.6 Removing and installing start/stop button and immobiliser reader coil for emergency start”, page 171](#)

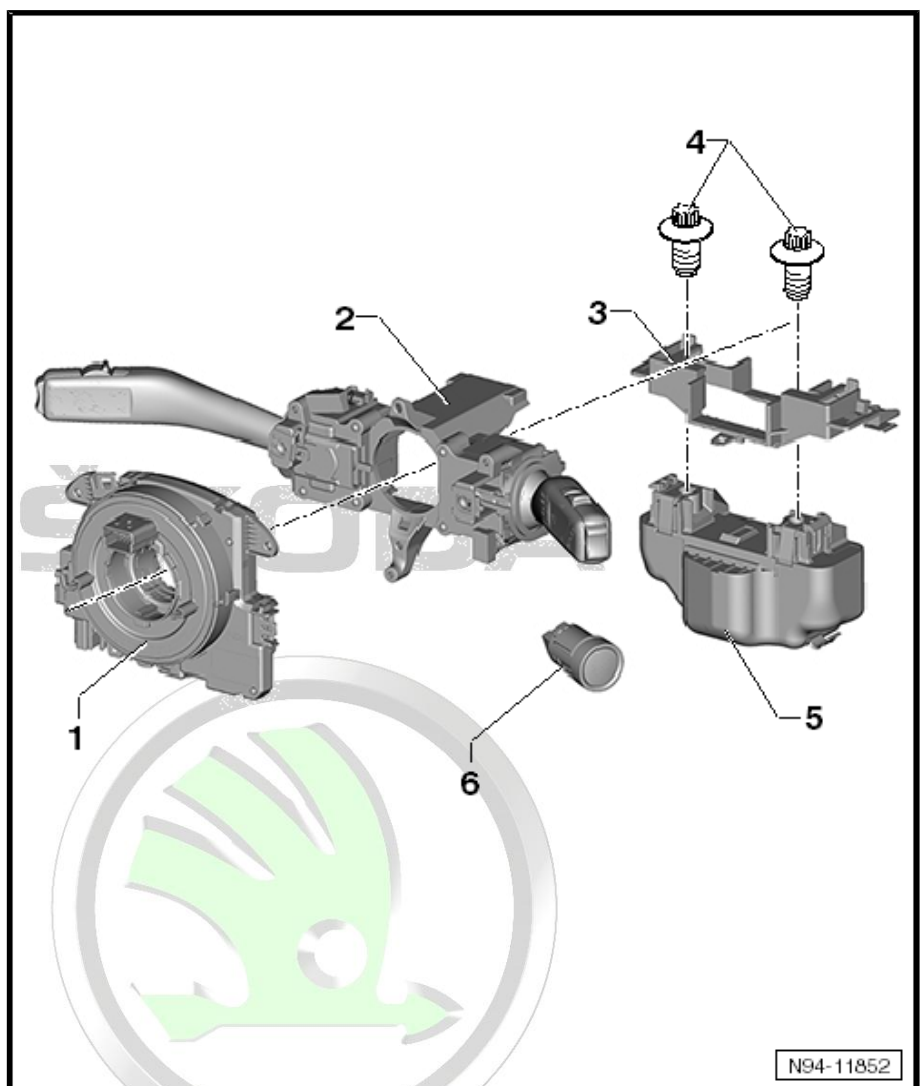



### 7.3.3 Removing and installing return ring with coil spring - F350- with integrated steering column electronics control unit - J527-

- Remove steering wheel ⇒ Body Work; Rep. gr. 69 . Before the steering wheel is removed from the steering column, the wheels must be in the straight ahead position.
- Removing top and bottom steering column trim ⇒ Body Work; Rep. gr. 70 .
- Lock the return ring -4- in the centre position (plug -3- is in the middle at the top) with adhesive tape -2-, if necessary with transport security.

Valeo manufacturer:

- Unscrew screws -arrows-, disconnect plug -1- and push return ring with control unit -4- off the steering column.

Kostal manufacturer:

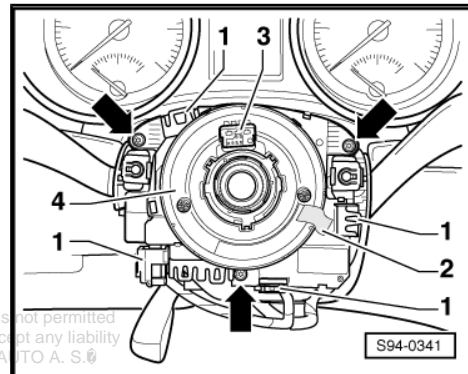

Protected by copyright. Copying for private or commercial purposes, in part or in whole, is not permitted unless authorised by ŠKODA AUTO A. S. ŠKODA AUTO A. S. does not guarantee or accept any liability with respect to the correctness of information in this document. Copyright by ŠKODA AUTO A. S. ©

- Depending on equipment - unlock plug connections -1-, -2-, -3-, -4- und -5- and pull off.
- Unscrew screw in direction of arrow -B-.
- Unlock retaining tabs in direction of arrow -A- and push return ring with control unit off the steering column.

#### Install

Installation is performed in the reverse order, pay attention to the following points:

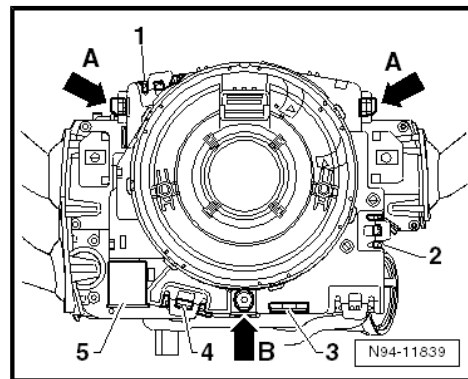

#### Note

- ◆ *When installing, the return ring with coil spring must be in the middle position and the wheels in the straight ahead position. In case of doubt about the correct positioning of the ring rotor, the middle position of the return ring must be set before installing the steering wheel*  
⇒ [“7.4 Setting middle position of the return ring with coil spring”, page 159](#) .
- ◆ *The indicator lever must be in the zero position so that the restoring segment does not protrude and break as a result.*
- ◆ *Kostal manufacturer - retaining tabs arrows -A- must audibly click into place.*
- ◆ *The new control unit must be coded after the installation see ⇒ Vehicle diagnostic tester.*

#### Tightening torques

Fixing screws for control unit	1.5 Nm
--------------------------------	--------



### 7.3.4 Removing and installing steering column combination switch

#### Removing



Note

The steering column is not shown in the illustration for purposes of clear presentation.

- Remove steering wheel ⇒ Body Work; Rep. gr. 69 . Before the steering wheel is removed from the steering column, the wheels must be in the straight ahead position.
- Removing top and bottom steering column trim ⇒ Body Work; Rep. gr. 70 .
- Remove return ring with coil spring  
 ⇒ [“7.3.3 Removing and installing return ring with coil spring F350 with integrated steering column electronics control unit J527”](#), page 158 .

Valeo manufacturer:

- Insert a small cross-head screwdriver through the opening arrow -A- and unlock the bottom catch peg.
- Press the upper locking lugs in direction of arrow -B- and slide the combination switch -1- out of the bearing on the steering lock in direction of arrow -C-.

Kostal manufacturer:

- Unscrew screw -arrow- and push the combination switch -1- out of the bracket on the steering lock.

#### Install

Installation is performed in the reverse order, pay attention to the following points:

- Make sure that all the retaining lugs and plug connections lock in place correctly.

#### Tightening torques

Fixing screw for combination switch	1 Nm
-------------------------------------	------

# ŠKODA

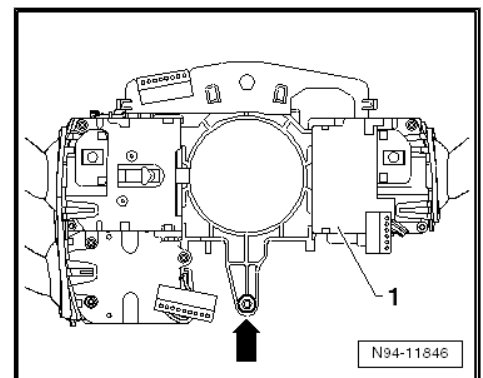
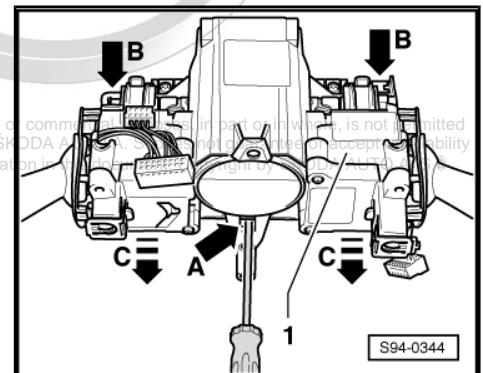

### 7.3.5 Contact assignment on the steering column electronics control unit - J527-

You can find the current contact assignment in the ⇒ Current flow diagrams, Electrical fault finding and Fitting locations.

### 7.4 Setting middle position of the return ring with coil spring

It is only carried out if there is a doubt about the correct setting of the centre position for the return ring rotor.



### Work procedure

- Put the front wheels in straight ahead position.
- Slowly turn the ring rotor manually to the right up to the stop.
- Slowly turn the ring rotor manually to the left up to the stop and count the number of turns.
- Slowly turn the ring rotor to the right by half of the counted turns in the centre position (top connector must be in horizontal position).
- Install steering wheel ⇒ Body Work; Rep. gr. 69 , if necessary lock ring rotor with transport security or adhesive tape.

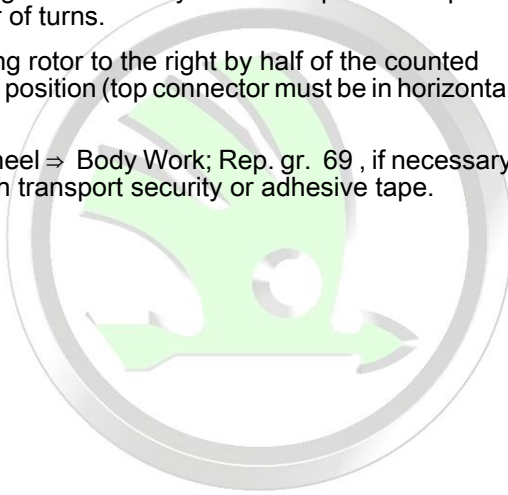

Protected by copyright. Copying for private or commercial purposes, in part or in whole, is not permitted unless authorised by ŠKODA AUTO A. S. ŠKODA AUTO A. S. does not guarantee or accept any liability with respect to the correctness of information in this document. Copyright by ŠKODA AUTO A. S. ©



## 8 Steering lock with ignition starter switch and lock cylinder

⇒ ["8.1 Removing and installing lock cylinder", page 161](#)

⇒ ["8.2 Removing and installing steering lock - installed up to 05.2010", page 162](#)

⇒ ["8.3 Removing and installing steering lock - installed as of 06.2010", page 163](#)

⇒ ["8.4 Removing and installing the ignition/starter switch", page 163](#)

⇒ ["8.5 Removing and installing ignition key anti-removal lock solenoid N376 ", page 164](#)

⇒ ["8.6 Contact assignment on the ignition/starter switch and the ignition key anti-removal lock", page 165](#)

### 8.1 Removing and installing lock cylinder



#### Caution

*The steering lock must not be moved without the lock cylinder, otherwise it would block completely. The blocked steering lock must be replaced*

#### Removing

- Disconnect battery earth strap  
 ⇒ ["1.1 Disconnecting and reconnecting battery", page 5](#)



#### Note

*The steering wheel must not be removed. For installing the fixing screws of the bottom trim panel for steering column, turn the steering wheel to the left by 90° and subsequently turn it to the right.*

- First of all remove the top and then the bottom steering column trim panel ⇒ Body Work; Rep. gr. 70 .
- Place the ignition key in the lock cylinder and turn to position "Ignition on" -2-.
- Lead a steel cable (about 1.2 mm in diameter) through the hole in the ignition key -arrow-.

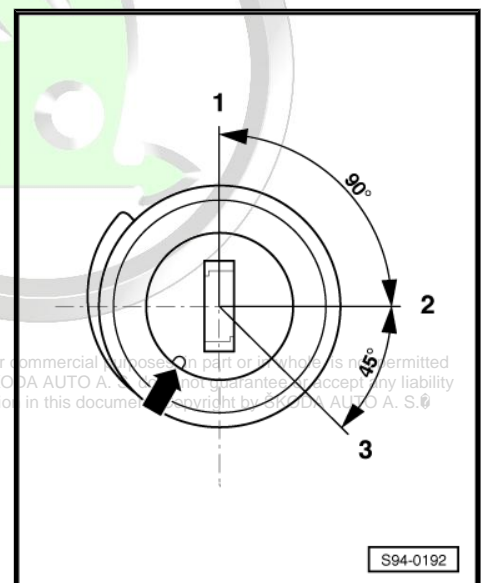



- Use the steel cable -2- to unlock the securing lever -3- of the lock cylinder -arrow- and to pull the lock cylinder out of the steering lock. For this step carefully slacken the cable to the reader coil of the vehicle immobiliser.

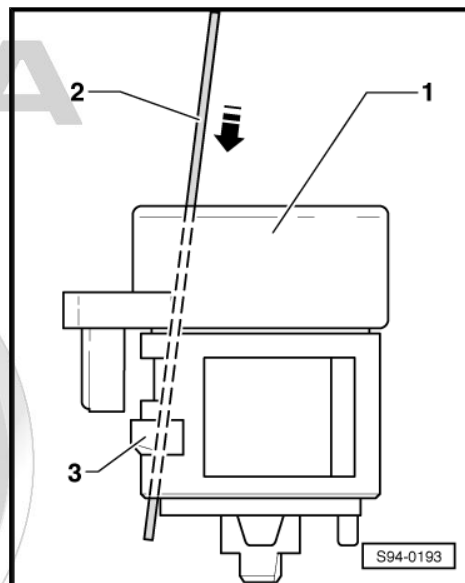

- Separate plug connection for immobiliser -1-.



**Note**

*The reader coil for the vehicle immobiliser is fixed to the lock cylinder and cannot be replaced separately.*

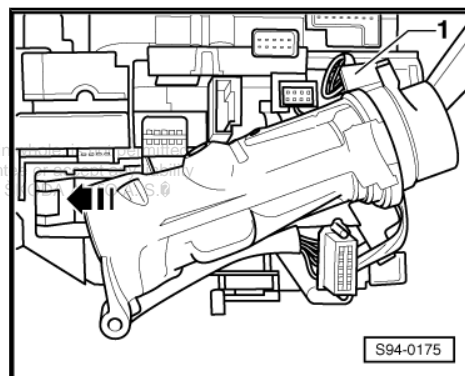

**Install**

- Place the ignition key in the lock cylinder and turn to position "Ignition on".
- Fit the plug connection together on the reading coil for immobiliser.
- Insert the lock cylinder with the reader coil into the steering lock housing until it clicks audibly into place.



**Note**

*Pay attention to the correct position of the cable to the reader coil of the vehicle immobiliser when inserting the lock cylinder.*

- Install steering column trim panels ⇒ Body Work; Rep. gr. 70 .
- Pay attention to the work sequence when connecting the battery earth strap  
⇒ ["1.1 Disconnecting and reconnecting battery", page 5](#) .

## 8.2 Removing and installing steering lock - installed up to 05.2010

The work sequence for removing and installing the steering lock is the same as for the switch mounting  
⇒ ["7.2.3 Removing and installing switch mounting on the steering column", page 152](#) .



## 8.3 Removing and installing steering lock - installed as of 06.2010

### Removing

- Remove steering wheel ⇒ Body Work; Rep. gr. 69 , bottom and top steering column trim panel ⇒ Body Work; Rep. gr. 70 .
- Remove return ring with coil spring  
 ⇒ [“7.3.3 Removing and installing return ring with coil spring F350 with integrated steering column electronics control unit J527 ”, page 158](#) .
- Remove steering column combination switch  
 ⇒ [“7.3.4 Removing and installing steering column combination switch” , page 159](#) .
- Disconnect the plug from the ignition starter switch and from the reader coil.
- Bore out fixing screws -1- and remove steering lock -3- with carrier of combination switch -2-.

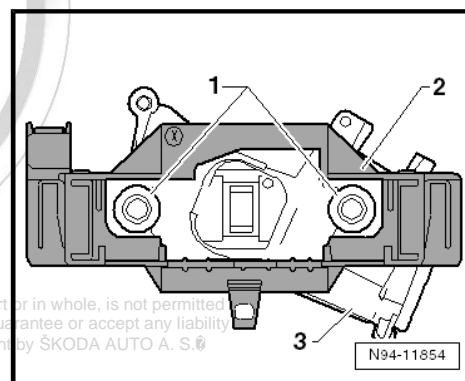

Protected by copyright. Copying for private or commercial purposes, in part or in whole, is not permitted unless authorised by ŠKODA AUTO A. S. ŠKODA AUTO A. S. does not guarantee or accept any liability with respect to the correctness of information in this document. Copyright by ŠKODA AUTO A. S. ©

- Press off catches -arrows- and remove carrier of combination switch -1- from steering lock housing -2-.

### Install

Installation is performed in the reverse order, pay attention to the following points:

- Screw on steering lock with new pull-off screws and tighten until the screw heads are torn off.
- Make sure that all the retaining lugs and plug connections lock in place correctly.

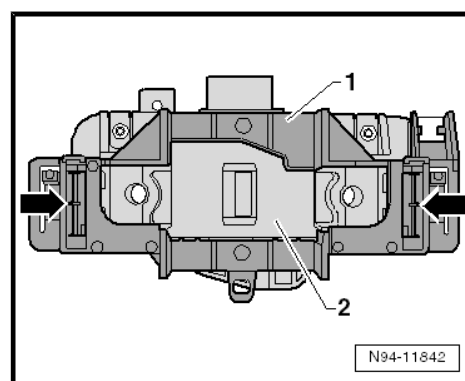

## 8.4 Removing and installing the ignition/ starter switch

### Removing

- Disconnect battery earth strap  
 ⇒ [“1.1 Disconnecting and reconnecting battery” , page 5](#) .



### Note

*The steering wheel must not be removed. For installing the fixing screws of the bottom trim panel for steering column, turn the steering wheel to the left by 90° and subsequently turn it to the right.*

- Switch off the ignition and all electrical components.
- First of all remove the top and then the bottom steering column trim panel ⇒ Body Work; Rep. gr. 70 .



- Release cover -1- (if present) for ignition starter switch by inserting a small screwdriver in the opening -arrow- and lift off the cover -movement arrow- through extensive levering off and remove.
- Disconnect plugs -3- from ignition starter switch -2-.

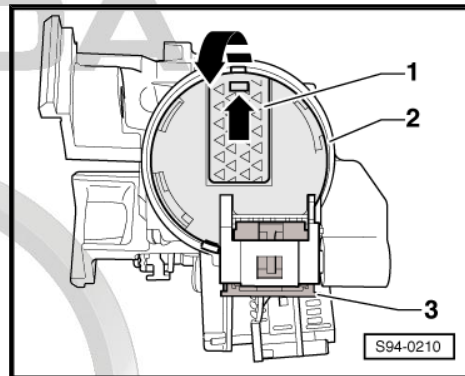

- Release ignition starter switch by inserting two small screwdrivers (e.g. watch-and-clock screwdriver) in the openings -arrows-and by levering off the retaining tabs.
- Pull ignition starter switch -1- out of the steering lock.

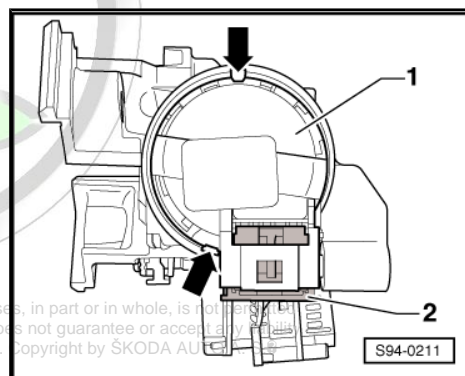

**Install**



**Note**

*When installing the ignition/starter switch and the steering lock must be in the same position, e.g. "Ignition ON".*

- Insert ignition starter switch into the steering lock until there is an audible click.
- Further installation occurs in reverse order.
- Pay attention to the work sequence when connecting the battery earth strap  
⇒ ["1.1 Disconnecting and reconnecting battery", page 5](#) .

## 8.5 Removing and installing ignition key anti-removal lock solenoid - N376-

Only on vehicles equipped with automatic gearbox.

**Removing**



**Note**

*The steering wheel must not be removed. For installing the fixing screws of the bottom trim panel for steering column, turn the steering wheel to the left by 90° and subsequently turn it to the right.*

- First of all remove the top and then the bottom steering column trim panel ⇒ Body Work; Rep. gr. 70 .



- Unlock catch -2- and pull out ignition key anti-removal lock magnet -1- out of the clamp in direction of the arrow.
- To do so unplug the connector simultaneously.

**Install**

Installation is carried out in the reverse order.

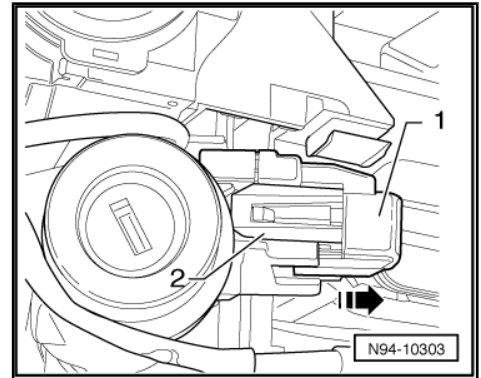

**8.6 Contact assignment on the ignition/ starter switch and the ignition key anti-removal lock**

**2-pin plug on the ignition key anti-removal lock -A- (for automatic transmission vehicles)**

- 1 - Ignition key anti-removal lock in, terminal 30
- 2 - Ignition key anti-removal lock earth

**6-pin plug at ignition starter switch -B-**

**i Note**

*The contacts -1- and -6- are marked on the 6-pin plug.*

- 1 - Ignition/starter switch output, terminal 50
- 2 - Terminal 30 voltage supply to ignition/starter switch
- 3 - Ignition/starter switch output, terminal S
- 4 - Ignition/starter switch output, terminal X
- 5 - Ignition/starter switch output, terminal P
- 6 - Ignition/starter switch output, terminal 15

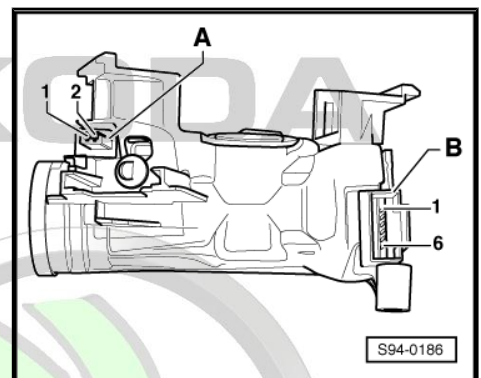

Protected by copyright. Copying for private or commercial purposes, in part or in whole, is not permitted unless authorised by ŠKODA AUTO A. S. ŠKODA AUTO A. S. does not guarantee or accept any liability with respect to the correctness of information in this document. Copyright by ŠKODA AUTO A. S. ©



## 9 Keyless unlocking of the vehicle/the steering, keyless start/stop – interface for entry and start system

⇒ [“9.1 General description”, page 166](#)

⇒ [“9.2 Fault recognition and fault display”, page 166](#)

⇒ [“9.3 Summary of components of the interface for entry and start system”, page 166](#)

⇒ [“9.4 Removing and installing control unit for entry and start authorisation J518”, page 168](#)

⇒ [“9.5 Aerials of the interface for entry and start system”, page 169](#)

⇒ [“9.6 Removing and installing start/stop button and immobiliser reader coil for emergency start”, page 171](#)

⇒ [“9.7 Steering lock with control unit for electronic steering column lock J764 \(ESCL\)”, page 172](#)

### 9.1 General description

The KESSY interface for entry and start system (Keyless Entry, Start and Exit System – a keyless access and start authorisation system) enables keyless unlocking and locking of the vehicle, as well as keyless engine start and switch-off. It is sufficient to carry the key with you. The lock with the control unit for ELV - J764- , which is a component of this system, replaces the mechanical steering lock.

The lock with the control unit for ELV - J764- generates the commands for switching on/off the S-contact, switching on/off the ignition (terminal 15) and the engine start/stop. These commands are transferred as signals to other vehicle components by the on-board supply control unit - J519- .

Overview of components

⇒ [“9.3 Summary of components of the interface for entry and start system”, page 166](#) .

When handling a fault, it is essential to know the functions and how to operate the entire interface for the entry and start system.

Detailed description of the function and operation of the interface for entry and start system:

- ◆ ⇒ Self-study programme No. 85 ; Interface for entry and start system in Škoda vehicles
- ◆ ⇒ Owner's manual Yeti

### 9.2 Fault recognition and fault display

The interface for entry and start system is equipped with self-diagnosis.

For fault recognition and fault finding use the ⇒ Vehicle diagnostic tester in the function “Targeted fault finding”.

### 9.3 Summary of components of the interface for entry and start system

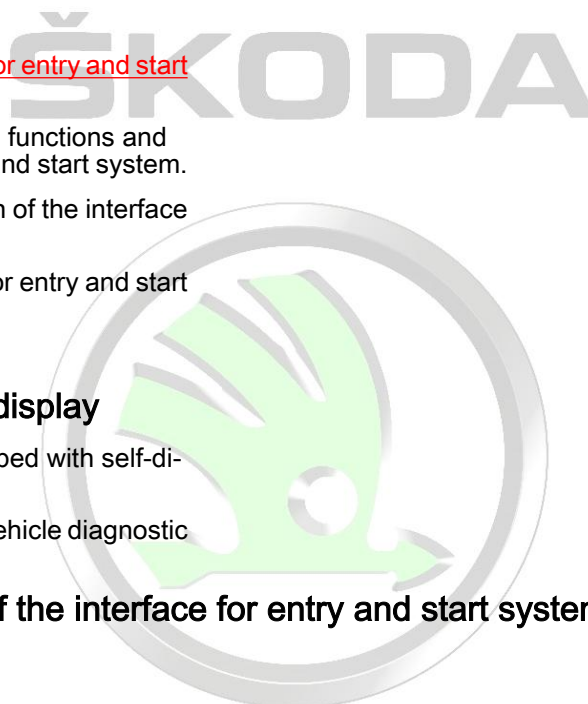

### 1 - Aerial under the rear bumper - R136-

- ❑ Removing and installing  
⇒ [“9.5.4 Removing and installing the rear aerial beneath the bumper”](#), page 170

### 2 - Aerial and sensors in the outer door handle on the driver's side - R134-

- ❑ not replaceable individually
- ❑ in the case of a fault, replace the complete outer door handle ⇒ Body Work; Rep. gr. 57

### 3 - Lock with control unit for ELV - J764-

- ❑ Removing and installing  
⇒ [“9.7 Steering lock with control unit for electronic steering column lock J764 \(ESCL\)”](#), page 172

### 4 - Access and start authorisation control unit - J518- behind the glove compartment/front passenger's side

- ❑ Removing and installing  
⇒ [“9.4 Removing and installing control unit for entry and start authorisation J518”](#), page 168

### 5 - Immobiliser reader coil for emergency start

- ❑ Removing and installing  
⇒ [“9.6 Removing and installing start/stop button and immobiliser reader coil for emergency start”](#), page 171

### 6 - Start/stop button

- ❑ Removing and installing  
⇒ [“9.6 Removing and installing start/stop button and immobiliser reader coil for emergency start”](#), page 171

### 7 - Aerial under the centre console - R138-

- ❑ Removing and installing  
⇒ [“9.5.1 Removing and installing the aerial under the centre console”](#), page 169

### 8 - Aerial and sensors in the outer door handle on the front passenger's side - R135-

- ❑ not replaceable individually
- ❑ in the case of a fault, replace the complete door handle ⇒ Body Work; Rep. gr. 57

### 9 - Aerial in the luggage compartment - R137-

- ❑ Removing and installing  
⇒ [“9.5.3 Removing and installing the rear aerial in the luggage compartment in the middle”](#), page 170

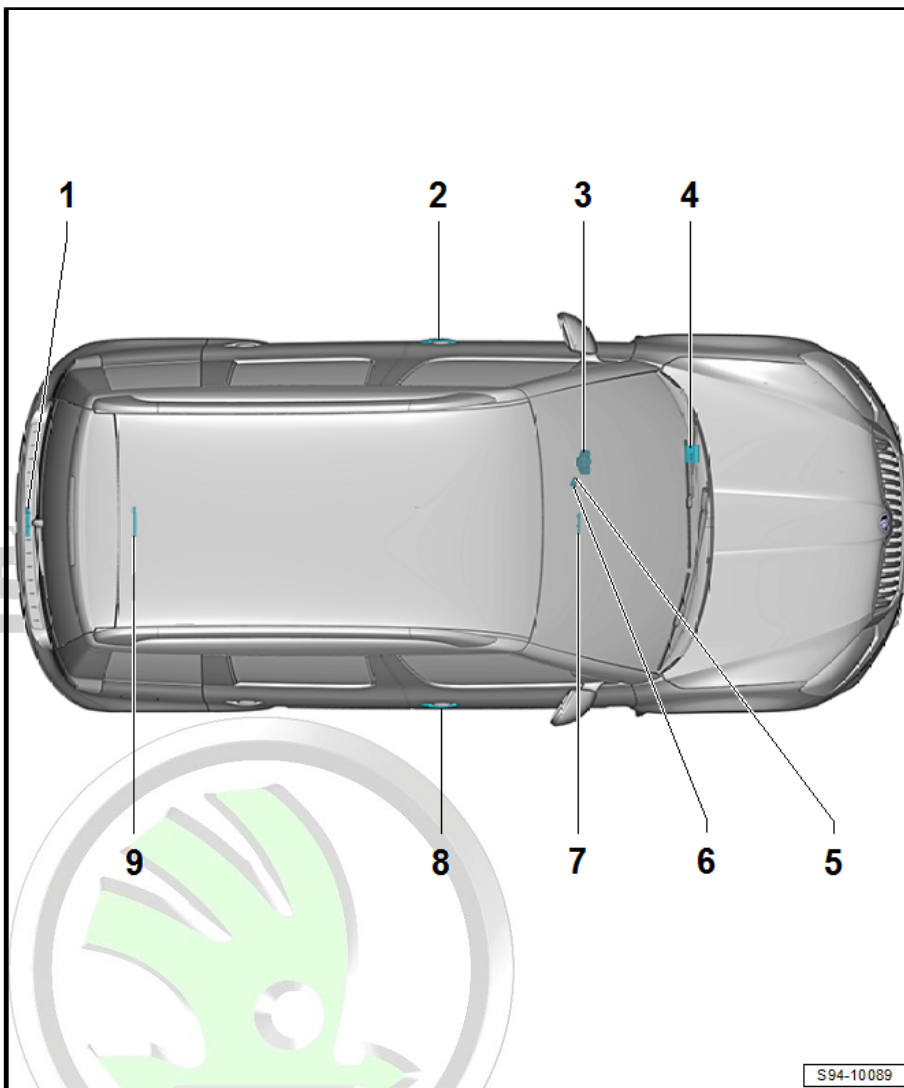

### Other components with which the interface for entry and start system communicates via the CAN bus

- ◆ Onboard supply control unit - J519-



- ◆ Data bus diagnostic interface Gateway - J533-
- ◆ Dash panel insert
- ◆ Selector lever of the automatic gearbox (vehicles with automatic gearbox)
- ◆ Engine control unit
- ◆ Control unit for ABS/ESP

## 9.4 Removing and installing control unit for entry and start authorisation - J518-

⇒ [“9.4.1 Removing and installing control unit for entry and start authorisation J518 - left-hand drive vehicles”, page 168](#)

⇒ [“9.4.2 Removing and installing control unit for entry and start authorisation J518 - right-hand drive vehicles”, page 169](#)

### 9.4.1 Removing and installing control unit for entry and start authorisation - J518- - left-hand drive vehicles

The control unit for entry and start authorisation - J518- is located above the brake pedal.

#### Removing

- Switch off the ignition and all electrical components.

Vehicles without knee airbag:

- Removing the left footwell vent on the driver side ⇒ Heating, Air Conditioning; Rep. gr. 80 .
- Remove uptake and remove crash strut for the brake pedal.

Vehicles with knee airbag:

- Remove knee airbag and support for knee airbag ⇒ Body Work; Rep. gr. 69 .
- Removing the left footwell vent on the driver side ⇒ Heating, Air Conditioning; Rep. gr. 80 .
- Removing the dash panel ⇒ Body Work; Rep. gr. 70 .
- Remove two screws and remove the left support of the cross member for dash panel with crash strut for brake pedal.

All vehicles:

- Raise the latches in direction of arrow -A- and move unit -1- with holder -2- out of the bearing on the brake pedal holder in direction of arrow -B-.
- Disconnect the plug by tilting out the catch clamp.
- Press of the catches and push out the control unit -1- from the mounting bracket -2-.

#### Install

Installation is performed in the reverse order, pay attention to the following points:

- If the control unit has been replaced, code using ⇒ Vehicle diagnostic tester. ⇒ Vehicle diagnostic tester must be connected and online.
- Test the complete system for proper operation.

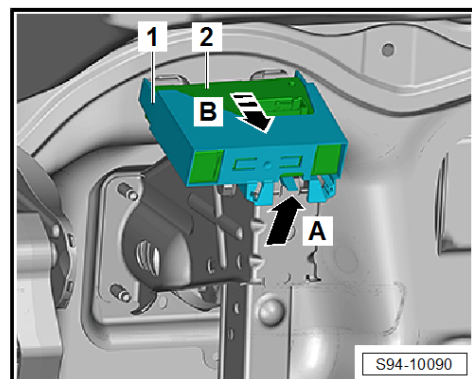

## 9.4.2 Removing and installing control unit for entry and start authorisation - J518- - right-hand drive vehicles

The control unit for entry and start authorisation - J518- is located behind the heating/air conditioning system control.

### Removing

- Switch off the ignition and all electrical components.
- Remove heating control or air conditioning system control ⇒ Heating, Air Conditioning; Rep. gr. 80 or ⇒ Heating, Air Conditioning; Rep. gr. 87 .
- Push off the locking lugs in direction of arrow -A- and move control unit -1- in direction of arrow -B- away from the holder -3-.
- Unlock and disconnect the plug connection -2- by tilting out the clamp.

### Install

Installation is performed in the reverse order, pay attention to the following points:

- If the control unit has been replaced, code using ⇒ Vehicle diagnostic tester. ⇒ Vehicle diagnostic tester must be connected and online.
- Test the complete system for proper operation.

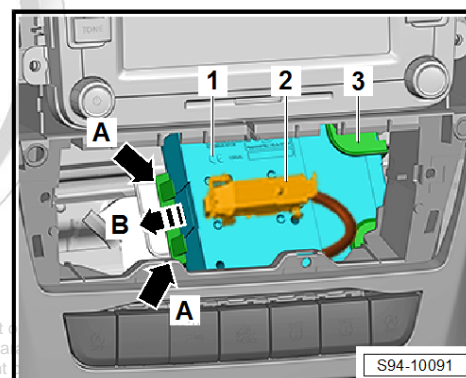

## 9.5 Aerials of the interface for entry and start system

⇒ [“9.5.1 Removing and installing the aerial under the centre console”, page 169](#)

⇒ [“9.5.2 Removing and installing aerials and sensors in the front outer door handles”, page 170](#)

⇒ [“9.5.3 Removing and installing the rear aerial in the luggage compartment in the middle”, page 170](#)

⇒ [“9.5.4 Removing and installing the rear aerial beneath the bumper”, page 170](#)

### 9.5.1 Removing and installing the aerial under the centre console

#### Removing

The aerial is located (fixed from both sides with adhesive tape) under the centre control in front of the gearshift lever.

- Switch off the ignition and all electrical components.



- Remove the centre console and air guide -2- ⇒ Body Work; Rep. gr. 68 .
- Light the floor covering and remove the aerial -1- from the bodyshell.
- Unplug connector -3-.

#### Install

Installation is performed in the reverse order, pay attention to the following points:

- If the aerial which was taken off is reused, a new double-sided adhesive tape must be used.

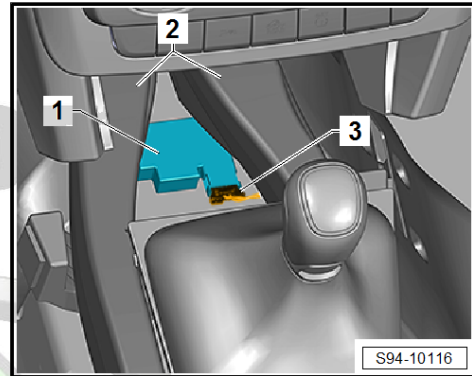

### 9.5.2 Removing and installing aerials and sensors in the front outer door handles

Not replaceable individually.

In the case of a fault, replace the complete outer door handle ⇒ Body Work; Rep. gr. 57 .

### 9.5.3 Removing and installing the rear aerial in the luggage compartment in the middle

Is located behind the rear seats underneath the floor covering in the middle.

#### Removing

- Switch off the ignition and all electrical components.
- Fold down the rear seats and raise the floor covering in the luggage compartment.
- Remove the connector -1- and carefully pull off the aerial -2- from the bearing in the bodyshell, e.g. with the removal tool for the inner lining of the door panel -MP 8-602/1- .

#### Install

- Fit connector and press the straddling dowels for aerial into the assembly openings.

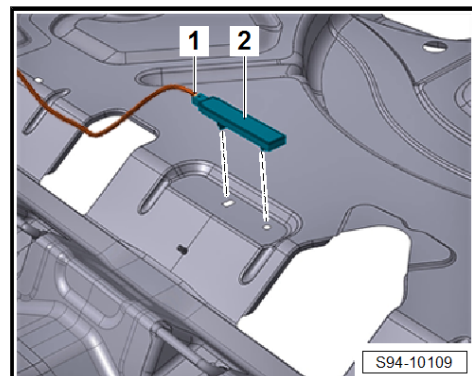

### 9.5.4 Removing and installing the rear aerial beneath the bumper

#### Removing

- Switch off the ignition and all electrical components.
- Remove rear bumper ⇒ Body Work; Rep. gr. 63 .



- Press off retaining tabs -arrows- and remove aerial -2-.
- Disconnect plug connection -1-.

**Install**

Installation is carried out in the reverse order.

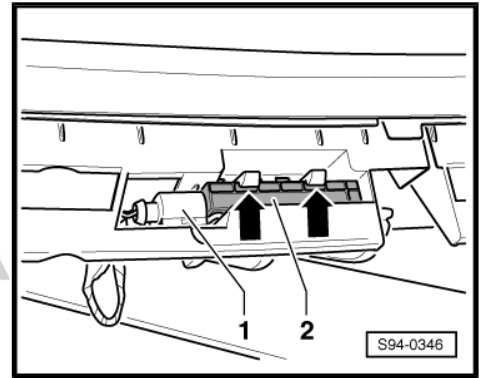

**9.6 Removing and installing start/stop button and immobiliser reader coil for emergency start**

**Removing**



**Note**

*The steering wheel must not be removed. For installing the fixing screws of the bottom trim panel for steering column, turn the steering wheel to the left by 90° and subsequently turn it to the right.*

- First of all remove the top and then the bottom steering column trim panel ⇒ Body Work; Rep. gr. 70 .
- Disconnect the plug from the button -1- and from the reader coil -2-.
- Insert two small cross-head screwdrivers (e.g. watch-and-clock screwdrivers) into the openings -arrows- and press the sheet pegs.
- Grip the bottom part of the button -1- and press it towards the outside from the bottom trim panel for steering column.
- When removing the reader coil -2- first of all remove the button, then carefully unclip the reader coil using the disassembly wedge - 3409- .

**Install**

- If removed, first of all insert the immobiliser reader coil -2- and lock in place.
- Then insert the button -1- into the bottom trim panel and press until the interlocking lugs lock into place.
- Mount plug and install the bottom and top steering column trim panel.

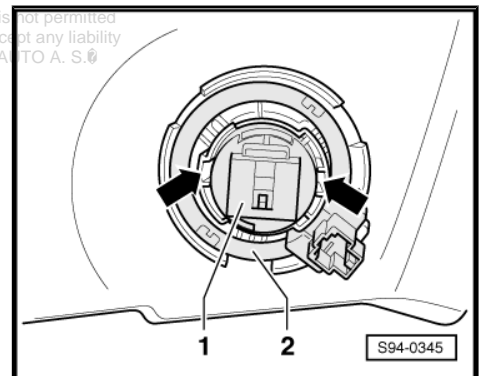

## 9.7 Steering lock with control unit for electronic steering column lock - J764- (ESCL)

⇒ [“9.7.1 Fault recognition and fault display”, page 172](#)

⇒ [“9.7.2 Removing and installing steering lock with control unit for ELV J764”, page 172](#)

### 9.7.1 Fault recognition and fault display

The lock with the control unit for ELV - J764- is equipped with self-diagnosis, which facilitates the fault finding.

For fault finding use the ⇒ Vehicle diagnostic tester in the function “Targeted fault finding”.

### 9.7.2 Removing and installing steering lock with control unit for ELV - J764-

#### Removing

- Remove steering wheel ⇒ Body Work; Rep. gr. 69 , bottom and top steering column trim panel ⇒ Body Work; Rep. gr. 70 .
- Remove return ring with coil spring  
⇒ [“7.3.3 Removing and installing return ring with coil spring F350 with integrated steering column electronics control unit J527”, page 158](#) .
- Remove steering column combination switch  
⇒ [“7.3.4 Removing and installing steering column combination switch”, page 159](#) .
- Unplug connector -2-.
- Bore out fixing screws -3- for steering lock -1-.
- Move the steering lock -1- with light force downwards in direction of arrow -A- and push out from steering column in direction of arrow -B-.

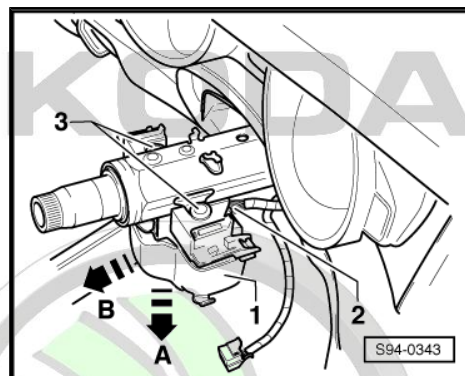

- Press off catches -arrows- and remove carrier of combination switch -1- from steering lock housing -2-.

#### Install

Installation is performed in the reverse order, pay attention to the following points:

- Screw on steering lock with new pull-off screws and tighten until the screw heads are torn off.
- Make sure that all the retaining lugs and plug connections lock in place correctly.
- After replacing, code the steering lock with the ⇒ Vehicle diagnostic tester. The ⇒ Vehicle diagnostic tester must be connected on-line.
- Test the complete system for proper operation.

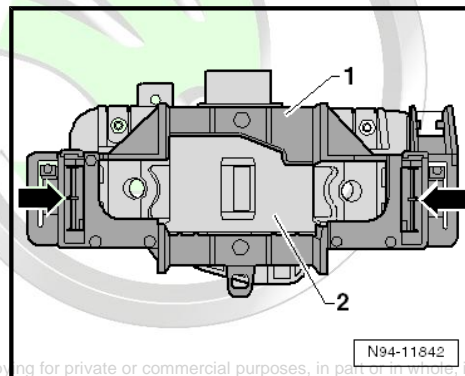

## 10 Parking aid and park steering assistant

⇒ ["10.1 General description", page 173](#)

⇒ ["10.2 Fault recognition and fault display", page 173](#)

⇒ ["10.3 Summary of components", page 174](#)

⇒ ["10.4 Remove and install parking aid control unit J446 or parking aid and park steering assistant control unit J791", page 175](#)

⇒ ["10.5 Remove and install the front parking aid warning buzzer H22", page 175](#)

⇒ ["10.6 Removing and installing the rear parking aid warning buzzer H15", page 176](#)

⇒ ["10.7 Removing and installing front parking aid sender", page 177](#)

⇒ ["10.8 Removing and installing rear parking aid sender", page 177](#)

⇒ ["10.9 Removing and installing the park steering assistant sender", page 178](#)

⇒ ["10.10 Parking aid sender holder and park steering assistant - making holes, assignment, fitting position, gluing procedure", page 178](#)

### 10.1 General description

The parking aid is installed in the following three versions:

- ◆ 4-channel system PDC: Is used to test the distance behind the vehicle (4 sensors).
- ◆ 8-channel system PDC: Is used to test the distance in front of and behind the vehicle (8 sensors).
- ◆ 8-channel system PDC+PLA: Is used to test the distance in front of and behind the vehicle and semi-automatic parking in the parallel parking spaces (as of MY 2014, also in perpendicular parking spaces) (parallel parking - 10 sensors, parallel and perpendicular parking - 12 sensors).

The park steering assistant system makes it possible to measure parallel parking spaces (as of MY 2014 also perpendicular parking spaces), to assess the area and due to the electrical mechanical assistance, the wheel rotation on the front axle during the parking movement.



#### Note

*When handling a fault it is absolutely essential to know the exact function of the parking aid and the park steering assistant.*

Detailed description of the function of the individual systems and safety measures:

- ◆ ⇒ Owner's manual Yeti
- ◆ ⇒ Self-study programme No. 72 ; Škoda Yeti, introduction of the vehicle

### 10.2 Fault recognition and fault display

The parking aid and park steering assistant are equipped with self-diagnosis, which facilitates the troubleshooting.



For fault finding use the ⇒ Vehicle diagnostic tester in the function "Targeted fault finding".

Perform the final control diagnosis in order to test the complete system ⇒ Vehicle diagnostic tester.

### 10.3 Summary of components



**Note**

Summary of details for the components ⇒ *Electronic Catalogue of Original Parts* .

**1 - Front right park steering assistant sender - G569- right vehicle side**

- in the front bumper
- Removing and installing ⇒ ["10.9 Removing and installing the park steering assistant sender"](#), page 178

**2 - Front parking aid sender from left to right -G255- , -G254- , -G253- , -G252-**

- in the front bumper
- Removing and installing ⇒ ["10.7 Removing and installing front parking aid sender"](#), page 177

**3 - Front left park steering assistant sender - G568- left vehicle side**

- in the front bumper
- Removing and installing ⇒ ["10.9 Removing and installing the park steering assistant sender"](#), page 178

**4 - The warning buzzer for the front parking aid - H22-**

- above the vehicle voltage control unit - J519-
- Removing and installing ⇒ ["10.5 Remove and install the front parking aid warning buzzer H22"](#), page 175

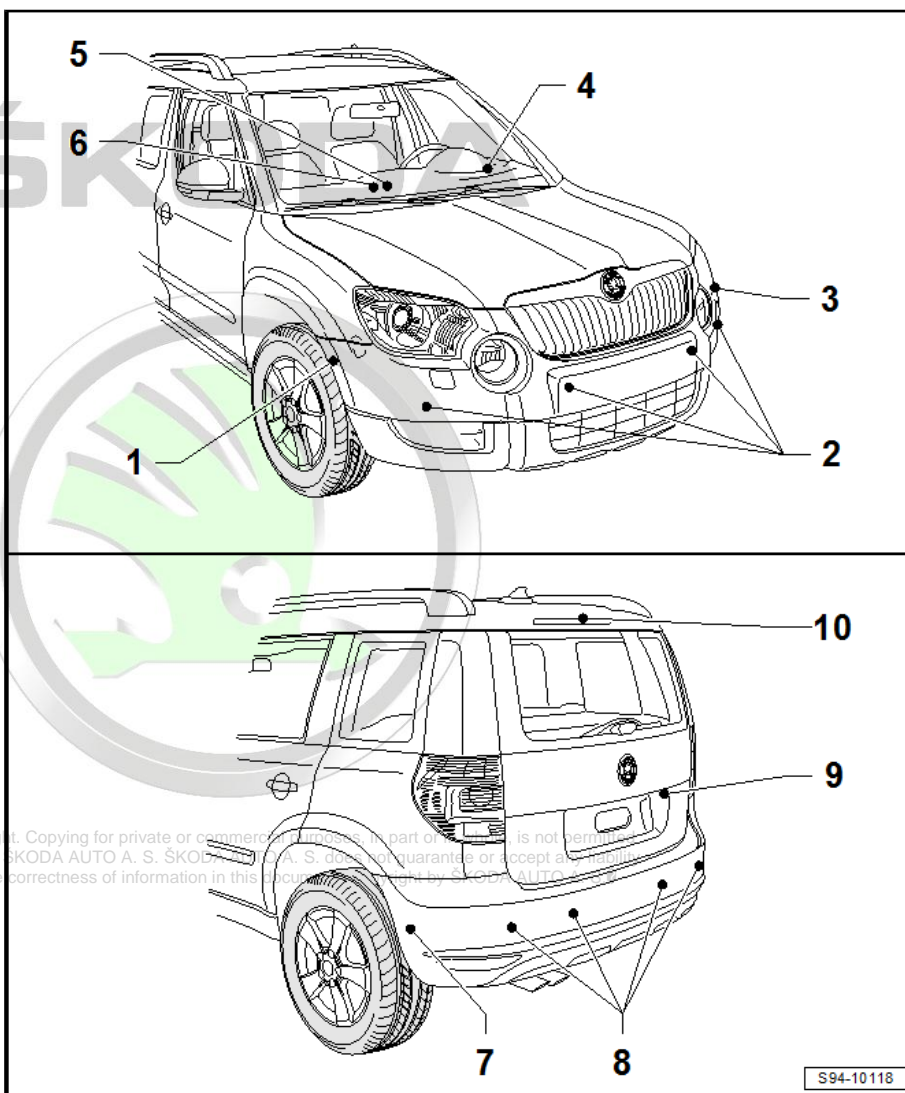

**5 - Button for parking aid - E266-**

- in the dash panel under the heater control
- Removing and installing ⇒ ["2.3 Removing and installing switches in centre console"](#), page 191

**6 - Park steering assistant button - E581-**

- in the dash panel under the heater control
- Removing and installing ⇒ ["2.3 Removing and installing switches in centre console"](#), page 191

**7 - Parking aid sender - G716- left or -G717- right**

- installed as of MY 2014

- ❑ Removing and installing  
⇒ [“10.9 Removing and installing the park steering assistant sender”, page 178](#)

#### 8 - Rear parking aid sender from left to right -G203- , -G204- , -G205- , -G206-

- ❑ in rear bumper
- ❑ Removing and installing ⇒ [“10.8 Removing and installing rear parking aid sender”, page 177](#)

#### 9 - Parking aid control unit - J446- or parking aid and park steering assistant control unit - J791-

- ❑ behind the rear luggage compartment trim panel
- ❑ Removing and installing  
⇒ [“10.4 Remove and install parking aid control unit J446 or parking aid and park steering assistant control unit J791 ”, page 175](#)

#### 10 - The warning buzzer for the rear parking aid - H15-

- ❑ at the rear right under the moulded headliner
- ❑ Removing and installing  
⇒ [“10.6 Removing and installing the rear parking aid warning buzzer H15 ”, page 176](#)

### 10.4 Remove and install parking aid control unit - J446- or parking aid and park steering assistant control unit - J791-

#### Removing

- Switch off all electrical components and take out the ignition key.
- Remove right luggage compartment trim panel, however do not remove completely ⇒ Body Work; Rep. gr. 70 .
- Release screws -arrows-.
- Release the plug -2- and disconnect it and take out the control unit -1-.

#### Install

Installation is performed in the reverse order, pay attention to the following points:

- If the control unit was replaced - code the control unit and, if equipped with the park steering assistant, adapt the tyre circumference with ⇒ Vehicle diagnostic tester.

#### Tightening torques

Fixing screws for control unit	1.5 Nm
--------------------------------	--------

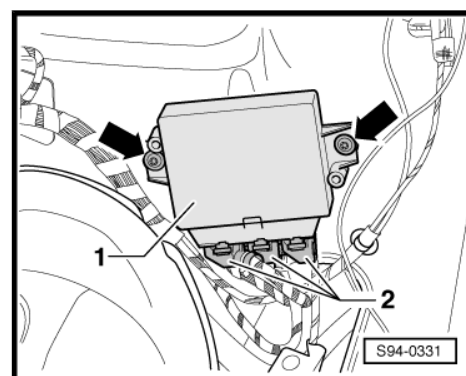

### 10.5 Remove and install the front parking aid warning buzzer - H22-

The front parking aid warning buzzer - H22- is located above the vehicle voltage control unit - J519- .

#### Removing

- Switch off all electrical components and take out the ignition key.
- Remove lower part of the dash panel insert on the driver's side  
⇒ Body Work; Rep. gr. 70 .

#### Left-hand drive:

- Remove onboard control unit - J519-  
⇒ [“2.1.3 Removing and installing the vehicle voltage control unit J519”, page 217](#)

ŠKODA AUTO A. S. ŠKODA AUTO A. S. does not guarantee or accept any liability with respect to the correctness of information in this document. Copyright by ŠKODA AUTO A. S. ©



- Press out the button rivets -arrows- from below.
- Disconnect plug and remove warning buzzer.

Right-hand drive:

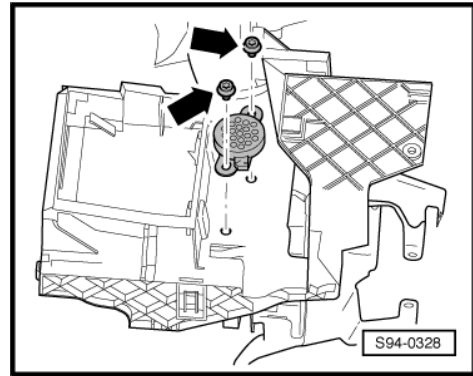

- Release and remove button rivets -arrows-.
- Disconnect plug and remove warning buzzer.

**Install**

Installation is performed in the reverse order, pay attention to the following points:

- Connect the plug and knock the button rivets in the end position.

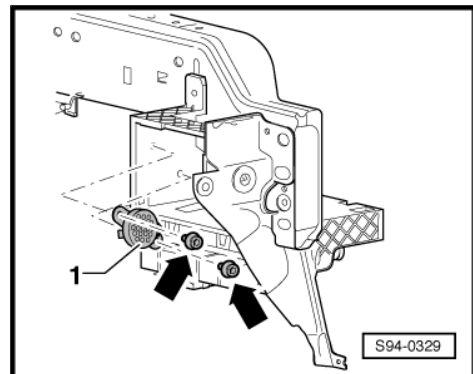

## 10.6 Removing and installing the rear parking aid warning buzzer - H15-

The warning buzzer for the rear parking aid aerial - H15- is located underneath the rear right headlining.

**Removing**

- Switch off all electrical components and take out the ignition key.
- Remove handles, top trim panel of pillar B, C, D and lower moulded headliner at rear => Body Work; Rep. gr. 70 .
- Slacken and remove button rivets -arrows-.
- Disconnect plug -1- and remove warning buzzer -2-.

**Install**

Installation is carried out in the reverse order.

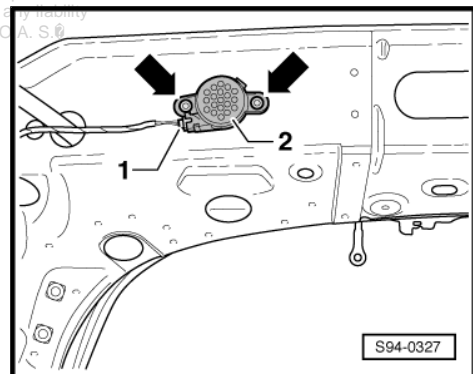



## 10.7 Removing and installing front parking aid sender



### Note

- ◆ When the sender (installed in the painted surface of the bumper) is replaced, paint the visible surface with the same colour as the bumper.
- ◆ The visible part of the sender must only be painted with a max. 125 µm thick layer of paint. Before painting the sender, the rear parts of the sender (terminal connection) must be affixed.
- ◆ Only the upper part (visible part) of the sender membrane is painted.
- ◆ To make it easier to remove the retaining tabs arrows -A-, you can use a larger pair of pliers for Seeger rings with bent jaws.

### Removing

- Switch off all electrical components and take out the ignition key.

Vehicles up to MY 2013:

- Remove front bumper ⇒ Body Work; Rep. gr. 63 .

Vehicles as of MY 2014:

- Middle sender- remove bumper ⇒ Body Work; Rep. gr. 63 , external sender - remove cover above the fog light ⇒ ["3.1 Removing and installing fog light", page 143](#) .

Protected by copyright. Copying for private or commercial purposes, in part or in whole, is not permitted unless SKODA AUTO A. S. SKODA AUTO A. S. does not guarantee or accept any liability with respect to the correctness of information in this document. Copyright by SKODA AUTO A. S.

### All vehicles:

- Detach the retaining lugs in direction of arrow -A- and press out the sender -1- on the outer side of the shock absorber inwards.
- Unplug connector -2-.

### Install

Installation is performed in the reverse order, pay attention to the following points:

- Displace the black silicone separation ring correctly onto the sender head.
- Both catch clamps must click audibly in place when installing.

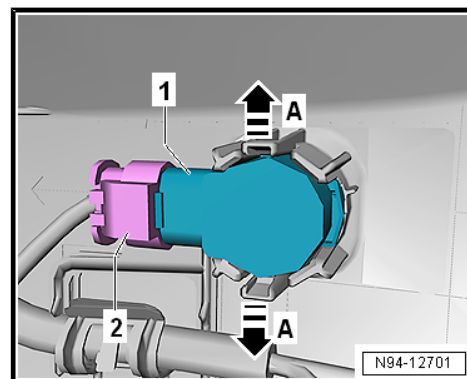

## 10.8 Removing and installing rear parking aid sender



### Note

- ◆ When the sender (installed in the painted surface of the bumper) is replaced, paint the visible surface with the same colour as the bumper.
- ◆ The visible part of the sender must only be painted with a max. 125 µm thick layer of paint. Before painting the sender, the rear parts of the sender (terminal connection) must be affixed.

### Removing

- Remove rear bumper ⇒ Body Work; Rep. gr. 63 .



- Detach the retaining lugs in direction of arrow -A- and press out the sender -1- on the outer side of the shock absorber inwards.
- Unplug connector -2-.

**Install**

Installation is performed in the reverse order, pay attention to the following points:

- Displace the black silicone separation ring correctly onto the sender head.
- Both catch clamps must click audibly in place when installing.

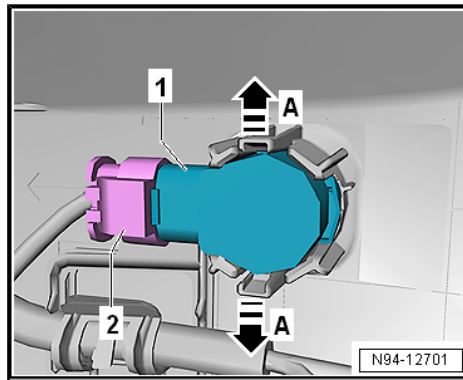

## 10.9 Removing and installing the park steering assistant sender



**Note**

- ◆ *If the sender or the sender holder is replaced, paint the visible area in the colour of the bumper.*
- ◆ *The visible part of the sender must only be painted with a max. 125 µm thick layer of paint. Before painting the sender, the rear parts of the sender (terminal connection) must be affixed.*

**Removing**

- Switch off all electrical components and take out the ignition key.

Sender in the front bumper:

- Slacken the wheelhouse liner on the side of the sender to be removed ⇒ Body Work; Rep. gr. 66 .

Sender in the rear bumper:

- Remove rear bumper ⇒ Body Work; Rep. gr. 63 .

All senders:

- Remove the fastening cloth on the sender holder -arrows- and press out the sender -1- on the outer side of the shock absorber inwards.
- Pull out the plug connector from the sender.

**Install**

Installation is carried out in the reverse order.

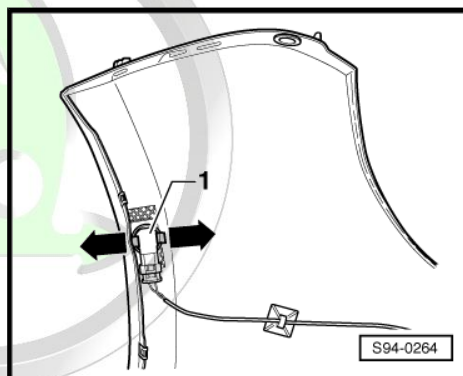

## 10.10 Parking aid sender holder and park steering assistant - making holes, assignment, fitting position, gluing procedure

**If the bumper is replaced, new sender holders must be affixed into the new bumper**

- ◆ Make holes in the new bumper see ⇒ Body Work; Rep. gr. 63 .



- ◆ Assignment of the sender holder ⇒ Electronic Catalogue of Original Parts .
- ◆ ⇒ [“10.10.1 Fitting position of the sender holders”, page 179](#)
- ◆ ⇒ [“10.10.2 Gluing procedure of the sender holders”, page 179](#)

### 10.10.1 Fitting position of the sender holders

#### Vehicles up to MY 2013:

The fitting position is determined by the peg on the holder -2- and the contour of the holder on the bumper -1-.

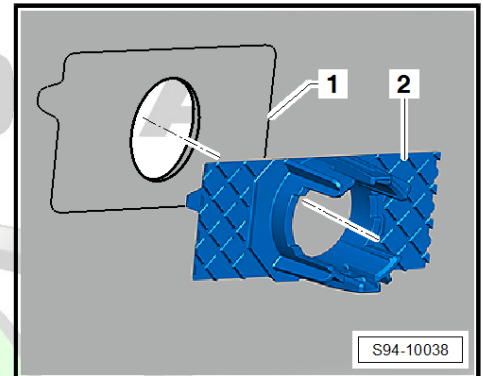

#### Vehicles as of MY 2014:

The fitting position is determined by the peg on the holder -2- and the contour of the holder on the bumper -1-.

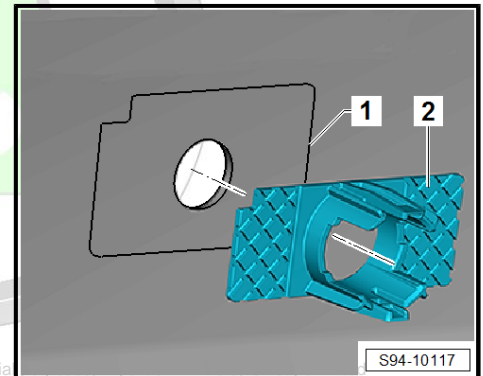

Protected by copyright. Copying for private or commercial use without the written permission of ŠKODA AUTO A. S. ŠKODA AUTO A. S. does not guarantee or accept any liability with regard to the correctness of information in this document. Copyright by ŠKODA AUTO A. S. ©

### 10.10.2 Gluing procedure of the sender holders



#### Note

- ◆ *During the gluing procedure of the sender holder for the parking aid, pay particular attention to centering the sender holder towards the opening in the bumper. The parking aid sender holder does not have a countersink collar. Therefore a centering pin must be used for precisely centering the holder in the bumper or gluing the holder with inserted parking aid sender on which the decoupling ring (black silicone ring) is placed.*
- ◆ *The temperature of the bumper and the sender holder must be between 15 °C and 25 °C during the gluing procedure.*



- Clean and thoroughly degrease the marked adhesive area -1- with isopropyl (technical alcohol).
- Evenly apply activator "3M glass/paint primer 4298UV", if necessary, "gas/paint primer K520" in the marked adhesive area -1-.
- Let the activator dry off for approx. 5 min.



#### Note

- ◆ *Pay attention to the fitting position*  
⇒ ["10.10.1 Fitting position of the sender holders", page 179](#)  
and the assignment of the sender holder ⇒ *Electronic Catalogue of Original Parts* .
- ◆ *The application force and the application time determine the durability of the bonding!*
- Remove the protective foils from both sides of the adhesive tape and press the sender holder -2- into the front bumper for approx. 10 seconds while applying high force.

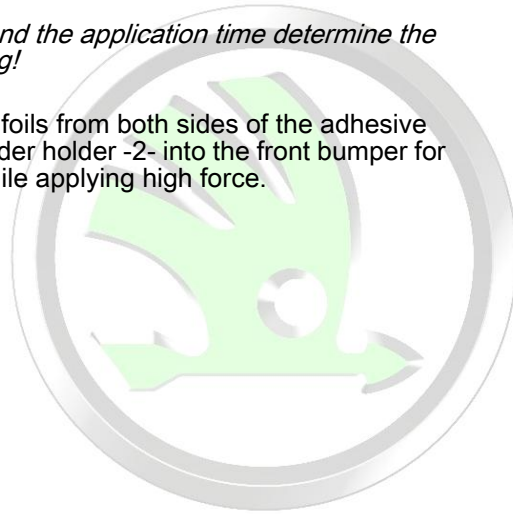
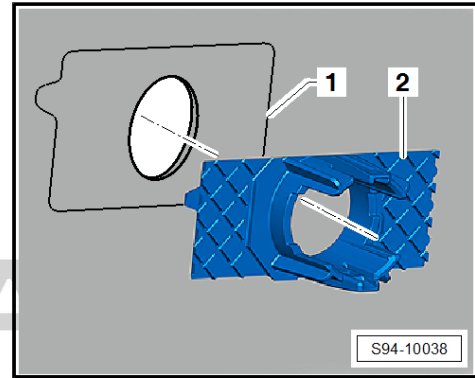

Protected by copyright. Copying for private or commercial purposes, in part or in whole, is not permitted unless authorised by ŠKODA AUTO A. S. ŠKODA AUTO A. S. does not guarantee or accept any liability with respect to the correctness of information in this document. Copyright by ŠKODA AUTO A. S. ©

## 11 Optical parking assistant (rear view camera)

⇒ [“11.1 General description”, page 181](#)

⇒ [“11.2 Summary of components: Rear view camera system”, page 181](#)

⇒ [“11.3 Removing and installing rear view camera system”, page 182](#)

⇒ [“11.4 Removing and installing the rear view camera spray nozzle”, page 183](#)

### 11.1 General description

The rear view camera helps the driver during the rear view driving. This works by showing the driver an image of the traffic situation behind the vehicle in the radio navigation system monitor.

When the ignition is switched on or the engine is running, the system will switch on by putting the gear into reverse when the radio navigation system is switched off.



#### Note

- ◆ *When handling a fault it is absolutely essential to know the function and operation of the rear view camera.*
- ◆ *Additional information and description of function ⇒ Owner's manual Yeti .*
- ◆ *Calibration of the rear view camera is not necessary.*
- ◆ *The rear view camera image does not appear on the radio navigation system until after a full system start. Like a computer, the radio navigation system needs a few seconds for the system to start after being switched on.*

The rear view camera consists of the following parts:

- ◆ Rear view camera system - R189-
- ◆ Control unit with display for radio and navigation system J503-

Protected by copyright. Copying for private or commercial purposes, in part or in whole, is not permitted without the written permission of ŠKODA AUTO A. S. ŠKODA AUTO A. S. does not guarantee or accept any liability with respect to the correctness of information in this document. Copyright by ŠKODA AUTO A. S. ©

### 11.2 Summary of components: Rear view camera system



### 1 - Control unit with display for radio and navigation system - J503-

- ❑ Removing and installing  
 ⇒ [“2 Navigation system Amundsen and Columbus”, page 43](#)

### 2 - Rear view camera system - R189-

- ❑ firmly connected with the grip strip
- ❑ Removing and installing  
 ⇒ [“11.3 Removing and installing rear view camera system”, page 182](#)
- ❑ Equipped with spray nozzle for camera lens from CW 22.2016
- ❑ Removing and installing handle with rear view camera  
 ⇒ [“11.3 Removing and installing rear view camera system”, page 182](#)
- ❑ Removing and installing spray nozzle  
 ⇒ [“11.4 Removing and installing the rear view camera spray nozzle”, page 183](#)

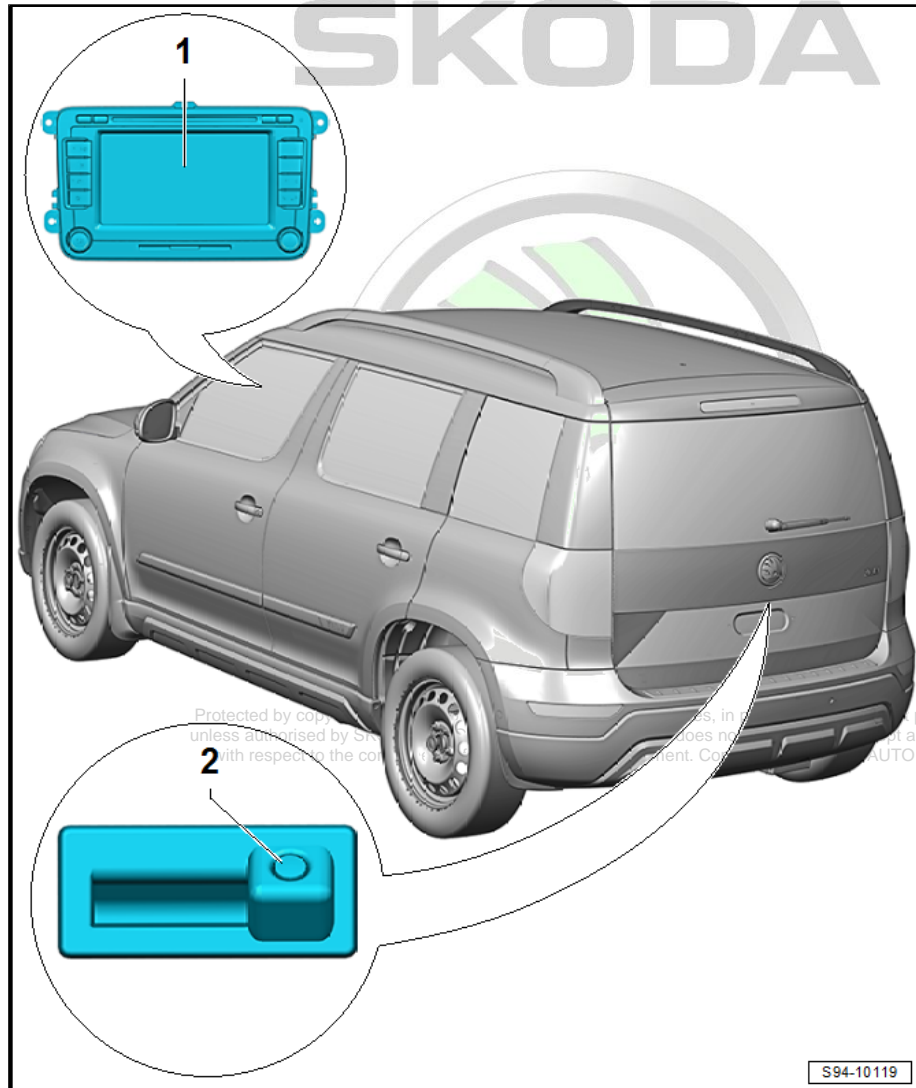

## 11.3 Removing and installing rear view camera system

The rear view camera - R189- is installed in the handle button of the rear lid and is firmly connected to the handle button.

The grip strip must be replaced when replacing the rear view camera.

### Removing

- Switch off the ignition and all electrical components.
- Remove the bottom tailgate trim panel ⇒ Body Work; Rep. gr. 70 .
- Disconnect the connectors on the tailgate and release the cables leading to the rear view camera.

Vehicles with handle recess attached using nuts:



- Unscrew nuts -arrows- and take off cover -1-.

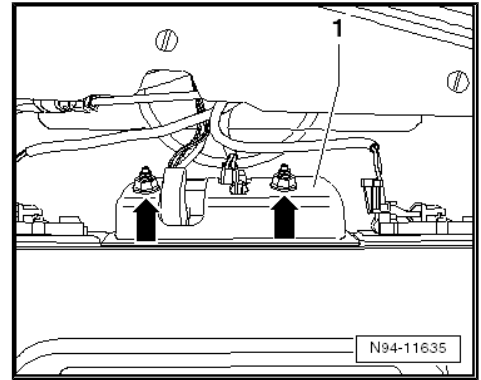

- Unlock and disconnect plug connection -1- and remove handle with the camera.

Vehicles with handle recesses attached using catches:

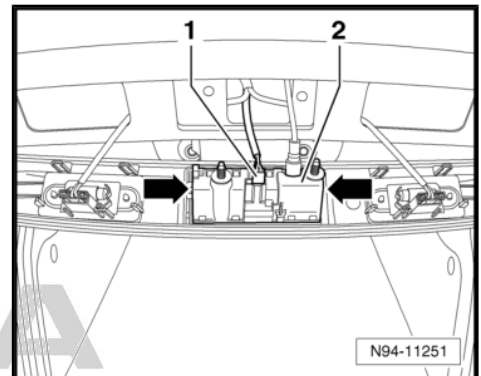

- Release the grip with the camera -1- from the catches -arrows- step by step and remove.
- Unlock and disconnect the connector of the rear view camera.

### Install

Installation is performed in the reverse order, pay attention to the following points:

- Vehicles with handle recesses attached using catches – Press the grip with the camera on the concealed frame step by step (starting from the left side and left rear tab) into the assembly opening until the retaining tabs click audibly into place.
- Perform a functional test.

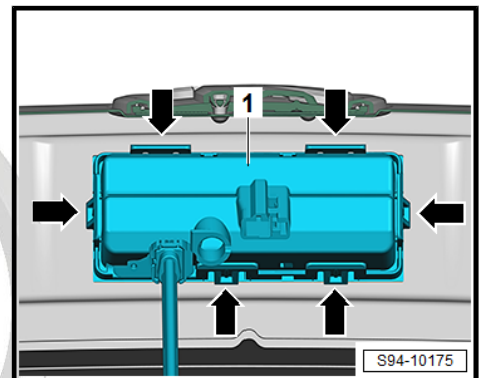

### Tightening torques

Fixing nut for handle with reversing camera	6 Nm
---	------

## 11.4 Removing and installing the rear view camera spray nozzle

Protected by copyright. Copying for private or commercial purposes, in part or in whole, is not permitted without the written consent of ŠKODA AUTO A. S. ŠKODA AUTO A. S. does not guarantee or accept any liability with respect to the correctness of information in this document. Copyright by ŠKODA AUTO A. S.

### Removing

- Switch off the ignition and all electrical components.
- Remove handle with camera  
 ⇒ [“11.3 Removing and installing rear view camera system”](#),  
[page 182](#) .
- Unlock and disconnect the feed hose by turning the fitting.



- Press off catch peg -arrow- and pull the spray nozzle -1- out from the handle -2-.

### Install

Installation is carried out in the reverse order.

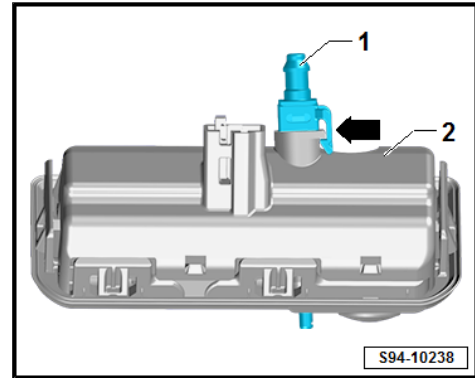

# ŠKODA



Protected by copyright. Copying for private or commercial purposes, in part or in whole, is not permitted unless authorised by ŠKODA AUTO A. S. ŠKODA AUTO A. S. does not guarantee or accept any liability with respect to the correctness of information in this document. Copyright by ŠKODA AUTO A. S. ©

## 12 Door entry lighting in the exterior mirror

⇒ [“12.1 Removing and installing door entry lighting and replacing light bulb”, page 185](#)

### 12.1 Removing and installing door entry lighting and replacing light bulb

#### Removing

- Switch off the ignition and all electrical components.
- Remove mirror glass ⇒ Body Work; Rep. gr. 66 .
- Slacken the top exterior mirror cover -1- from the catches -arrows- and carefully remove it.
- Unscrew screws -2-.

Protected by copyright. Copying for private or commercial purposes, in part or in whole, is not permitted unless authorised by ŠKODA AUTO A. S. ŠKODA AUTO A. S. does not guarantee or accept responsibility with respect to the correctness of information in this document. Copyright © ŠKODA AUTO A. S.

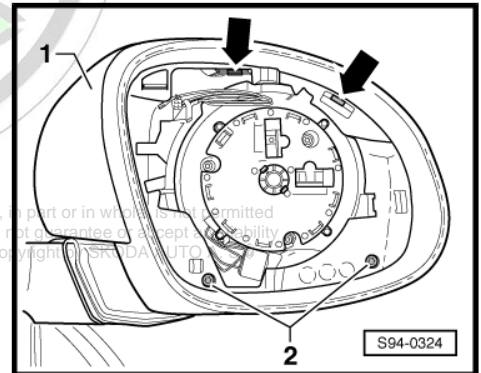

- Lower the bottom part of the exterior mirror -2- downwards.
- Turn the socket to change the bulb -1- -arrow-, remove the defective light bulb (W5W) and replace it.
- Unplug the plug -3- to change the door entry lighting and disconnect it (the complete part -2- must be replaced).

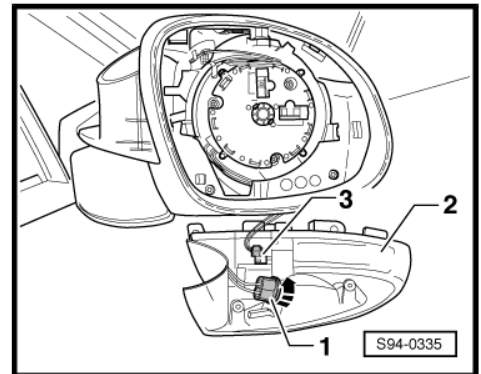

#### Install

Installation is performed in the reverse order, pay attention to the following points:

- Perform a functional test (illumination, mirror adjustment).

#### Tightening torques

Fixing screws for bottom cover	0.8 Nm
--------------------------------	--------



## 13 Side turn signal in the exterior mirror

⇒ "13.1 Removing and installing the turn signal light in the exterior mirror", page 186

### 13.1 Removing and installing the turn signal light in the exterior mirror

#### Removing

- Switch off the ignition and all electrical components.
- Remove mirror glass ⇒ Body Work; Rep. gr. 66 .
- Slacken the top exterior mirror cover -1- from the catches -arrows- and carefully remove it.
- Unscrew screws -2-.

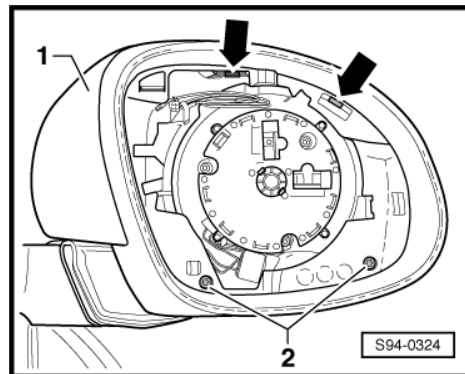

- Lower the bottom part of the exterior mirror -2- downwards.
- Unlock the plug connection -3- and disconnect.



#### Note

*In the event of a fault of the turn signal light, the complete bottom part of the exterior mirror -2- must be replaced.*

**Install** ed by copyright. Copying for private or commercial purposes, in part or in whole, is not permitted unless authorised by ŠKODA AUTO A. S. ŠKODA AUTO A. S. does not guarantee or accept any liability

Installation is performed in the reverse order, pay attention to the following points:

- Perform a functional test (illumination, mirror adjustment).

#### Tightening torques

Fixing screws for bottom cover	0.8 Nm
--------------------------------	--------

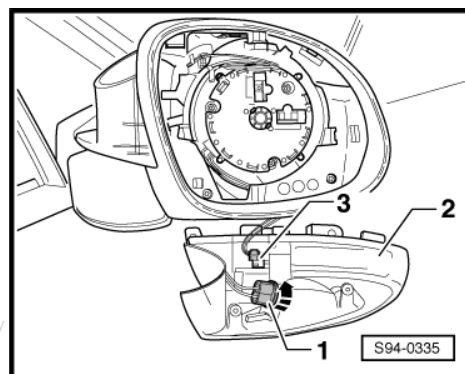

## 96 – Lights, bulbs, switches - interior

### 1 Lights and switches in the roof cover

⇒ [“1.1 Removing and installing the front interior light”, page 187](#)

⇒ [“1.2 Replace light bulbs for front interior light”, page 187](#)

⇒ [“1.3 Removing and installing the sliding roof switch”, page 188](#)

⇒ [“1.4 Removing and installing the interior light for the tail end of the vehicle”, page 188](#)

#### 1.1 Removing and installing the front interior light



Note

*The shape and control of the lighting can be designed differently (depending upon equipment), the assembly work is identical.*

- Switch off the ignition and all electrical components.
- Loosen the cover -2- out of the catches using the disassembly wedge -3409- and tilt out towards the bottom.
- Unscrew screws -arrows- and tilt out the interior light -1- and suspend it from the installation frame -3-.
- Disconnect plug.

Installation is carried out in the reverse order.

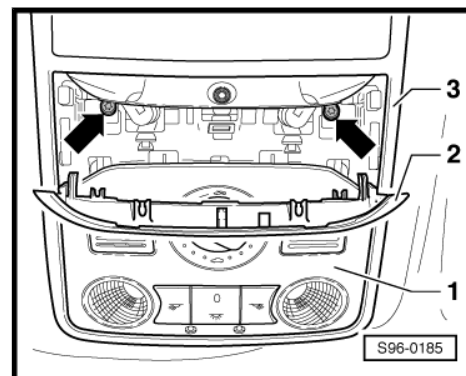

#### 1.2 Replace light bulbs for front interior light

- Remove front interior light (it is not necessary to disconnect the plug connection)  
 ⇒ [“1.1 Removing and installing the front interior light”, page 187](#) .
- Turn the socket with the light bulb -arrow- and remove.

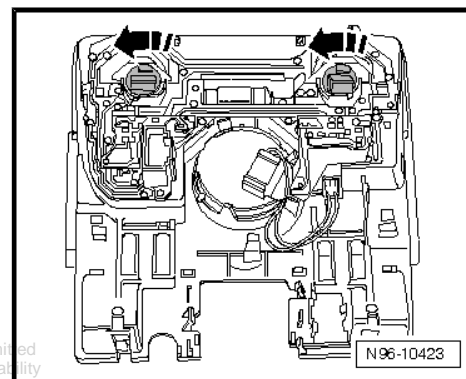



- Carefully remove the light bulb from the socket and replace (W5W).

Installation is carried out in the reverse order.

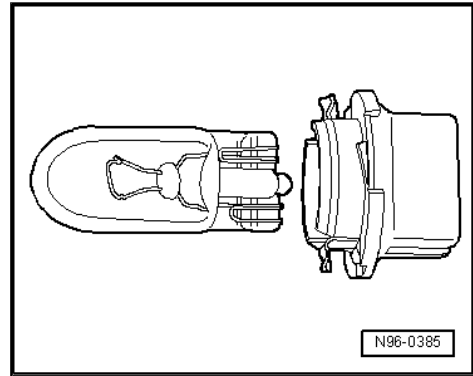

### 1.3 Removing and installing the sliding roof switch

- Remove front interior light  
⇒ ["1.1 Removing and installing the front interior light", page 187](#).
- Unlock plug connection and remove from the switch in the light.
- Unlock the catches -arrows- and remove the sliding roof switch from the trim panel.

Installation is carried out in the reverse order.

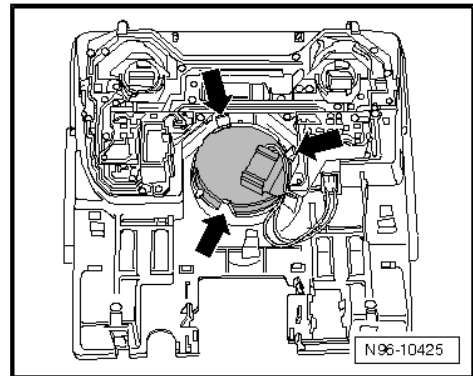

### 1.4 Removing and installing the interior light for the tail end of the vehicle

#### Removing

- Carefully release the catch -arrow- with a small cross-head screwdriver, tilt out the interior light and remove.
- Disconnect plug.

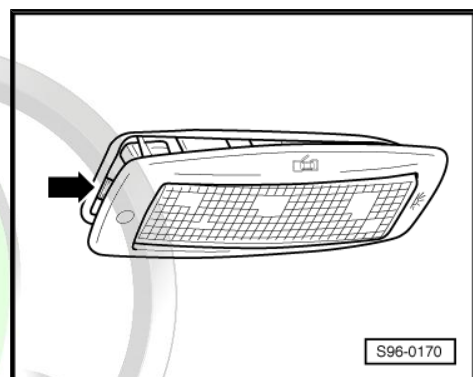



- Push out lens -arrow- and replace light bulb (C5W).

**Install**

Installation is carried out in the reverse order.

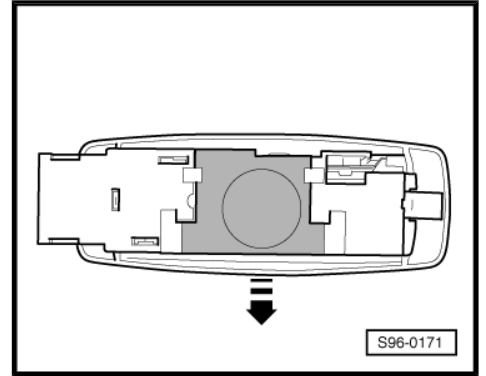

ŠKODA



Protected by copyright. Copying for private or commercial purposes, in part or in whole, is not permitted unless authorised by ŠKODA AUTO A. S. ŠKODA AUTO A. S. does not guarantee or accept any liability with respect to the correctness of information in this document. Copyright by ŠKODA AUTO A. S.®

## 2 Lights and switches in the dash panel

⇒ [“2.1 Removing and installing light switch”, page 190](#)

⇒ [“2.2 Removing and installing the headlight range control adjuster”, page 190](#)

⇒ [“2.3 Removing and installing switches in centre console”, page 191](#)

⇒ [“2.4 Removing and installing hazard warning lights button”, page 191](#)

⇒ [“2.5 Removing and installing the warning light for front passenger airbag switch-off function”, page 192](#)

⇒ [“2.6 Removing and installing glove box light”, page 192](#)

### 2.1 Removing and installing light switch

#### Removing

- Switch off the ignition and all electrical components.
- Turn the turning handle of the light switch to position “0”.
- Press in the handle of the light switch firmly in direction of arrow -1- and turn to the right in direction of arrow -2-.
- Hold the handle in this position and pull out the light switch in direction of arrow -3-.
- Disconnect plug connection at switch.

#### Install

- Mount plug.
- Turn the turning handle of the light switch to position “0”.
- Carefully push the light switch into the opening until the switch audibly locks into place.

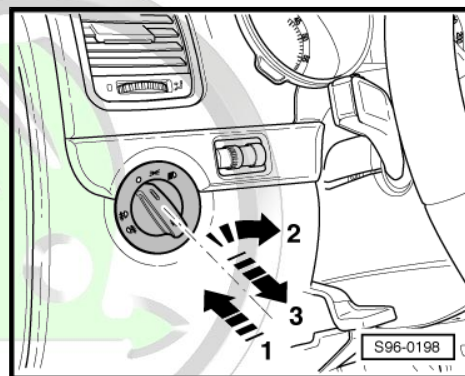

### 2.2 Removing and installing the headlight range control adjuster

#### Removing

- Switch off the ignition and all electrical components.
- Remove lower part of the dash panel insert on the driver's side  
⇒ Body Work; Rep. gr. 70 .
- Disconnect plug.

Protected by copyright. Copying for private or commercial purposes, in part or in whole, is not permitted unless authorised by ŠKODA AUTO A. S. ŠKODA AUTO A. S. does not guarantee or accept any liability with respect to the correctness of information in this document. Copyright by ŠKODA AUTO A. S. ©



- Press together the lateral securing tabs on the adjuster for the headlamp range control -arrows-.
- Pull the adjuster for headlamp range control -A- to the rear out of the mounting frame in the dash panel casing.

**i** Note

*The adjuster for headlamp range control and instrument lighting rheostat form a single unit.*

**Install**

- Insert the adjuster for headlamp range control into the mounting frame and press in place.
- Push the securing tabs outwards until they interlock with the retaining tabs.
- Mount the plug connection.
- Install the bottom part of dash panel on the drivers' side.

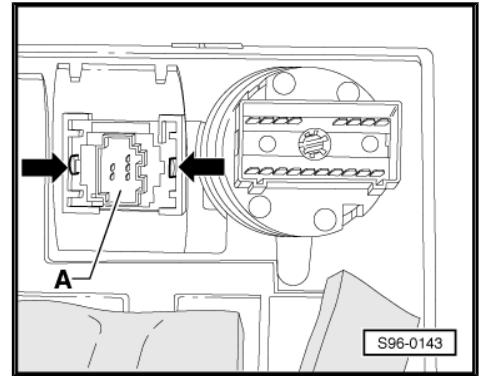

## 2.3 Removing and installing switches in centre console

**i** Note

*The assembly work is identical for all the switches.*

**Removing**

- Switch off the ignition and all electrical components.
- Loosen the cover -2- out of the catches using the disassembly wedge - 3409- .
- Carefully lever off the removed switch -1- with two screwdrivers -arrows- and push out of the centre console.

**Install**

- Press the switch into the centre console until the retaining tabs click audibly into place.
- Perform a functional test.

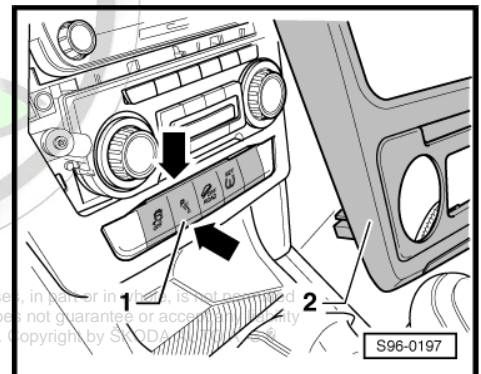

## 2.4 Removing and installing hazard warning lights button

**Removing**

- Switch off the ignition and all electrical components.



- Remove centre vent -1- ⇒ Heating, Air Conditioning; Rep. gr. 80 .
- Disconnect the plug connection at switch -2-.
- Press the switch -2- from the centre vent to the outside -arrow-.

**Install**

Installation is carried out in the reverse order.

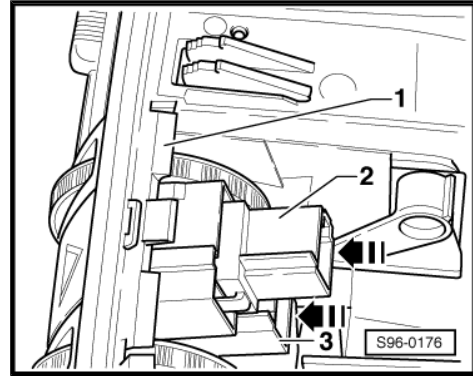

## 2.5 Removing and installing the warning light for front passenger airbag switch-off function

**Removing**

- Switch off the ignition and all electrical components.
- Remove centre vent -1- ⇒ Heating, Air Conditioning; Rep. gr. 80 .
- Disconnect the plug from the warning light -3- for front passenger airbag deactivation.
- Press the warning light -3- from the centre vent to the outside -arrow-.

**Install**

Installation is carried out in the reverse order.

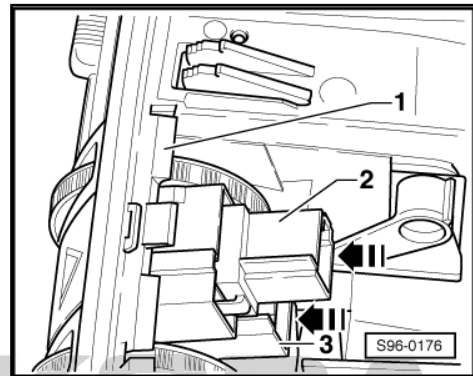

## 2.6 Removing and installing glove box light

**Removing**

- Switch off all electrical components and take out the ignition key.
- Loosen the light out of the dash panel using a disassembly wedge - 3409- or a small screwdriver.

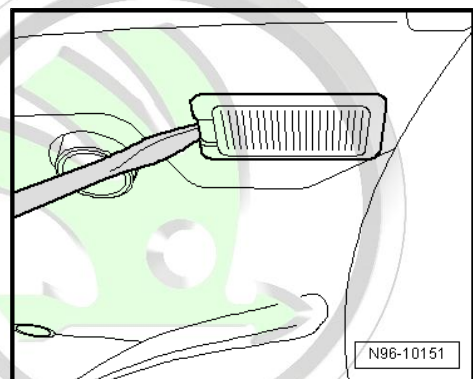

Protected by copyright. Copying for private or commercial purposes, in part or in whole, is not permitted unless authorised by ŠKODA AUTO A. S. ŠKODA AUTO A. S. does not guarantee or accept any liability with respect to the correctness of information in this document. Copyright by ŠKODA AUTO A. S. ©



- Unplug connector -arrow-.
- Replace defective light bulb (C3W).

#### Install

Installation is performed in the reverse order, pay attention to the following points:

- Perform a functional test.

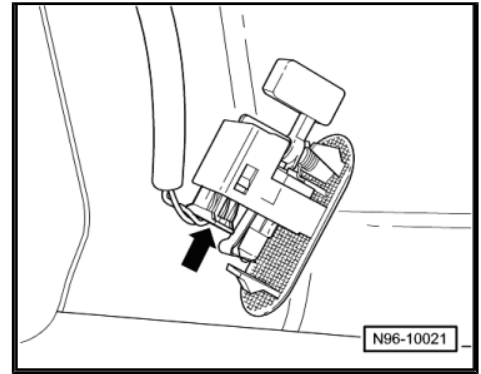

# ŠKODA



Protected by copyright. Copying for private or commercial purposes, in part or in whole, is not permitted unless authorised by ŠKODA AUTO A. S. ŠKODA AUTO A. S. does not guarantee or accept any liability with respect to the correctness of information in this document. Copyright by ŠKODA AUTO A. S. ©



### 3 Lights and switches in the centre console

⇒ [“3.1 Removing and installing switch for inside actuation of the central locking”, page 194](#)

#### 3.1 Removing and installing switch for inside actuation of the central locking

##### Removing

- Switch off the ignition and all electrical components.
- Remove the centre console -2- ⇒ Body Work; Rep. gr. 68 .
- Disconnect the plug connection from the switch -1-.
- Press the lateral retaining clamps of the switch using a cross-head screwdriver and remove the switch -1- from the centre console.

##### Install

Installation is carried out in the reverse order.

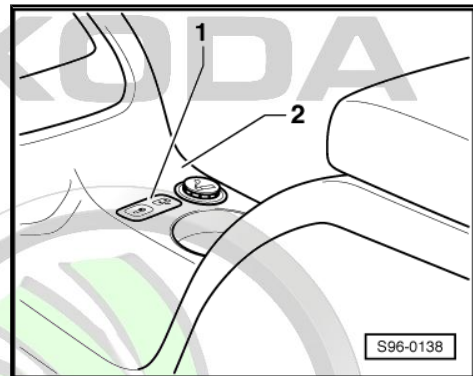

Protected by copyright. Copying for private or commercial purposes, in part or in whole, is not permitted unless authorised by ŠKODA AUTO A. S. ŠKODA AUTO A. S. does not guarantee or accept any liability with respect to the correctness of information in this document. Copyright by ŠKODA AUTO A. S.

## 4 Interior lights and switches

⇒ **“4.1 Removing and installing interior monitoring deactivation switch E267 and deactivation button for vehicle inclination sender E360”, page 195**

### 4.1 Removing and installing interior monitoring deactivation switch -E267- and deactivation button for vehicle inclination sender -E360-

#### Removing

- Remove the trim panel of pillar B -1- on the driver's side ⇒ Body work; Rep. gr. 70 .
- Disconnect plug connection at switch.
- Press the lateral retaining clamp of the button using a cross-head screwdriver and remove the button -2- from the trim panel.

#### Install

Installation is carried out in the reverse order.

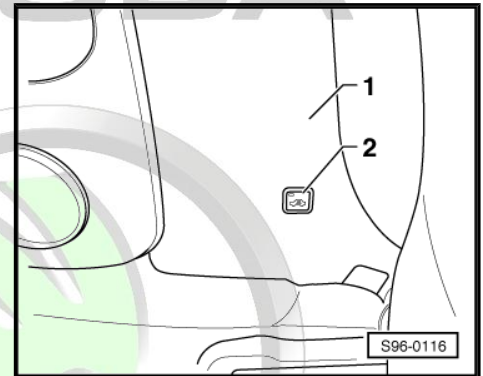

Protected by copyright. Copying for private or commercial purposes, in part or in whole, is not permitted unless authorised by ŠKODA AUTO A. S. ŠKODA AUTO A. S. does not guarantee or accept any liability with respect to the correctness of information in this document. Copyright by ŠKODA AUTO A. S. ©



## 5 Lights and switches in the door

⇒ [“5.1 Removing and installing the switch for the power window lifter”, page 196](#)

⇒ [“5.2 Removing and installing the mirror adjustment switch”, page 196](#)

⇒ [“5.3 Removing and installing the switch for the power windows on the front and rear passenger’s side”, page 197](#)

⇒ [“5.4 Removing and installing door warning lamp”, page 197](#)

### 5.1 Removing and installing the switch for the power window lifter

- Lever off, tilt out and remove the switches -1- using the disassembly wedge - 3409- .
- Disconnect plug.

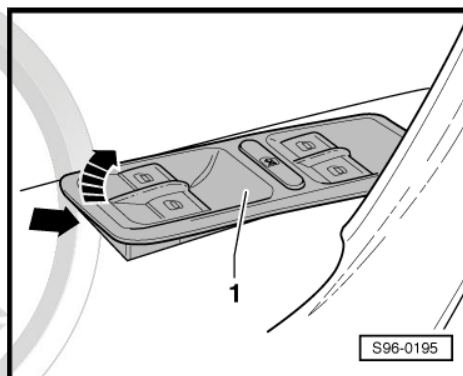

- Slacken the control element out of the retaining tabs -arrows- and remove.

Installation is carried out in the reverse order.

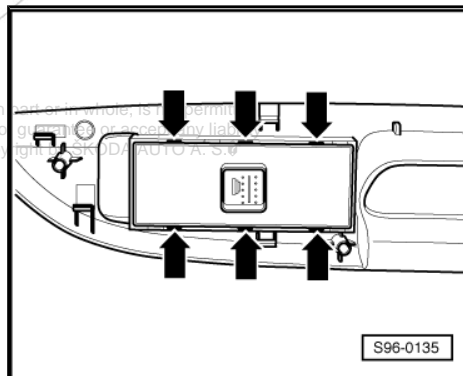

### 5.2 Removing and installing the mirror adjustment switch

#### Removing

- Switch off the ignition and all electrical components.
- Unclip cover for treble speaker -2-.
- Disconnect plug connection -1-.

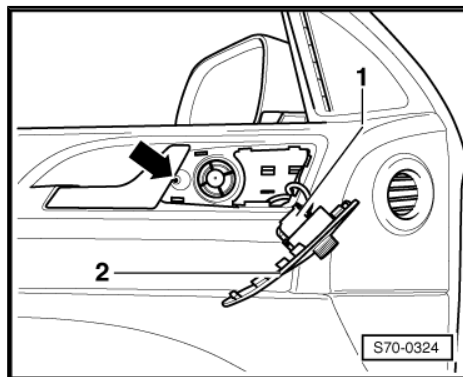



- Remove operating unit -arrows-.

**Install**

Installation is carried out in the reverse order.

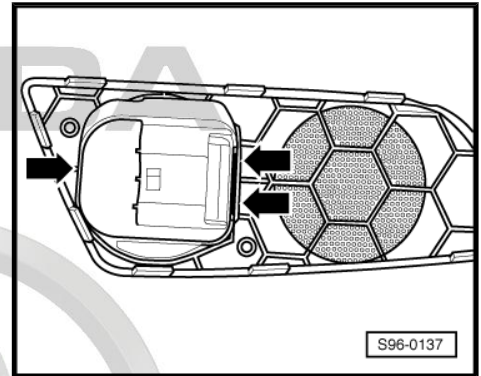

### 5.3 Removing and installing the switch for the power windows on the front and rear passenger's side

**Removing**

- Switch off the ignition and all electrical components.
- Unclip the cover -1- for the treble speaker with the switch out of the door trim panel.
- Unplug connector -2-.

Protected by copyright. Copying for private or commercial purposes, in part or in full, is prohibited unless authorised by ŠKODA AUTO A. S. ŠKODA AUTO A. S. does not guarantee the accuracy of the information with respect to the correctness of information in this document. Copyright by ŠKODA AUTO A. S.

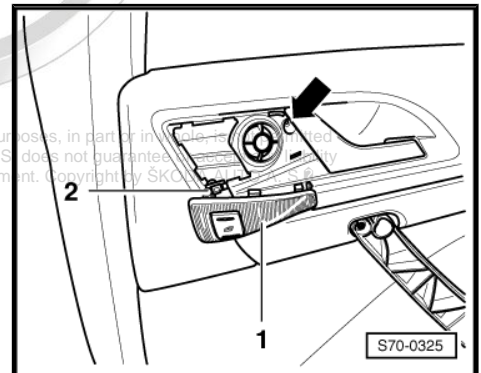

- Carefully lever out the switch from the catches -arrows-.

**Install**

Installation is carried out in the reverse order.

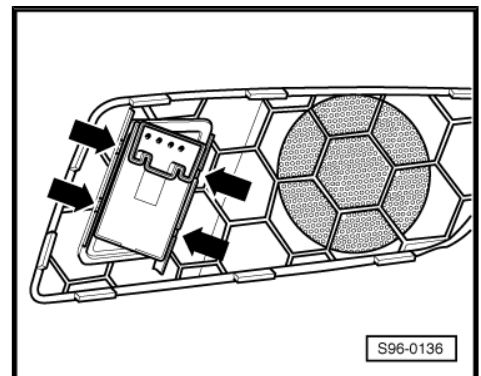

### 5.4 Removing and installing door warning lamp

**Removing**

- Switch off the ignition and all electrical components.



- Use a cross-head screwdriver to grasp behind the lens and carefully lever out lamp.
- Disconnect the plug connection.

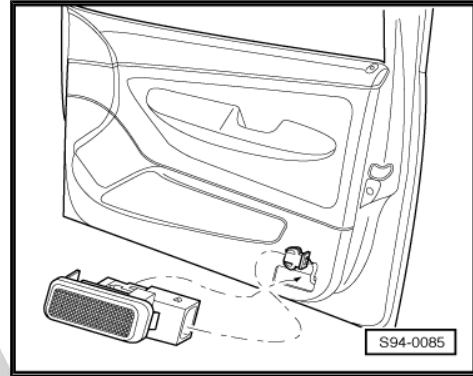

- Tilt out the cover of the light -arrow-.

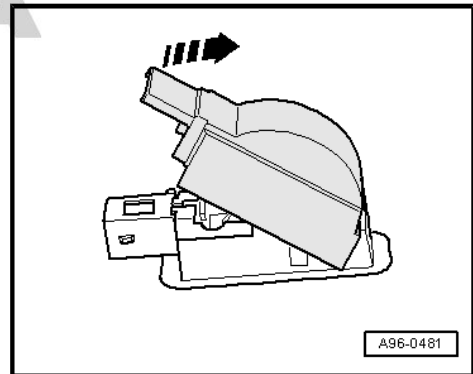

- Carefully pull the light bulb (W5W) out of the socket and mount a new one.

**Install**

Installation is carried out in the reverse order.

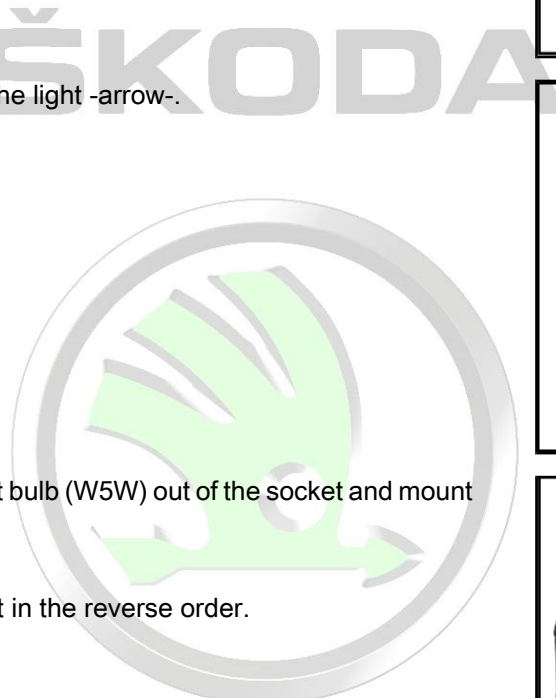
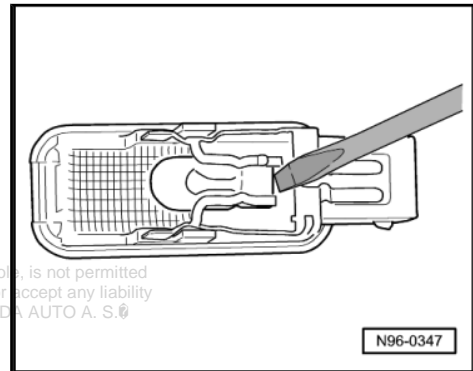

Protected by copyright. Copying for private or commercial purposes, in part or in whole, is not permitted unless authorised by ŠKODA AUTO A. S. ŠKODA AUTO A. S. does not guarantee or accept any liability with respect to the correctness of information in this document. Copyright by ŠKODA AUTO A. S. ©

## 6 Lights and switches in the luggage compartment

⇒ [“6.1 Removing and installing luggage compartment light”, page 199](#)

⇒ [“6.2 Removing and installing luggage compartment light - removable lamp”, page 199](#)

⇒ [“6.3 Removing and installing the tailgate release switch”, page 200](#)

⇒ [“6.4 Removing and installing the tailgate release control motor”, page 200](#)

### 6.1 Removing and installing luggage compartment light

- Switch off all electrical components and take out the ignition key.
- Lever out the light at the recess point using the disassembly wedge - 3409- or a small screwdriver and remove it from the trim panel.

ŠKODA

- Push out the defective light bulb (W5W) and replace it.
  - If necessary disconnect the plug and remove the light.
- Installation is carried out in the reverse order.

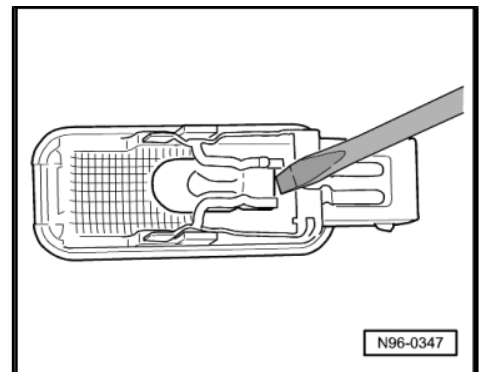
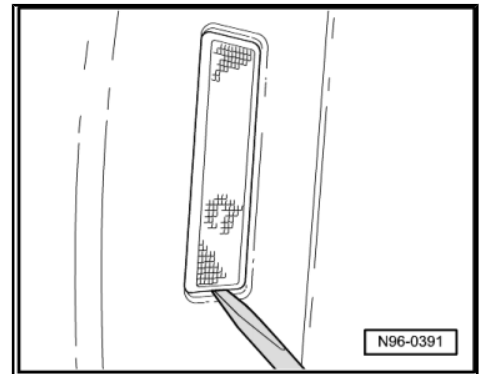

### 6.2 Removing and installing luggage compartment light - removable lamp



#### Note

Protected by copyright. Copying for private or commercial purposes, in part or in whole, is not permitted without the prior written permission of SKODA AUTO A. S. SKODA AUTO A. S. does not guarantee or accept any liability with respect to the correctness of information in this document. Copyright by SKODA AUTO A. S. ©

- ◆ *After being removed the lamp can also be used outside the vehicle cockpit.*
- ◆ *Replace description of function and battery, see ⇒ Operating Instruction Yeti.*



- Grab the light -1- at the positions shown by the arrows -A- and remove in direction of arrow -B-.

Installation is carried out in the reverse order.

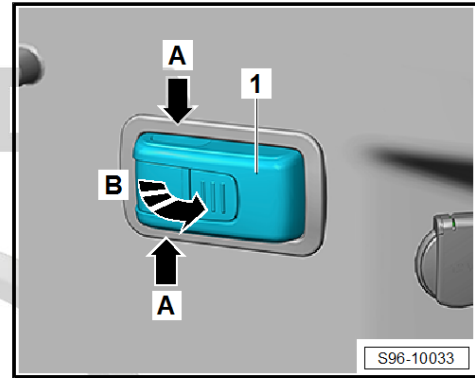

### 6.3 Removing and installing the tailgate release switch

⇒ Body Work; Rep. gr. 55 .

### 6.4 Removing and installing the tailgate release control motor

The tailgate release control motor is a component part of the tailgate lock and cannot be replaced separately.

Remove and install the tailgate lock ⇒ Body Work; Rep. gr. 55 .

Protected by copyright. Copying for private or commercial purposes, in part or in whole, is not permitted unless authorised by ŠKODA AUTO A. S. ŠKODA AUTO A. S. does not guarantee or accept any liability with respect to the correctness of information in this document. Copyright by ŠKODA AUTO A. S. ©

## 7 Anti-theft warning system

⇒ [“7.1 General points”, page 201](#)

⇒ [“7.2 Alarm horn H12”, page 201](#)

⇒ [“7.3 Removing and installing the contact switch for the bonnet F266”, page 202](#)

⇒ [“7.4 Removing and installing interior monitoring deactivation switch E267 and deactivation button for vehicle inclination sender E360”, page 203](#)

⇒ [“7.5 Removing and installing interior monitoring sensor G273 and vehicle inclination sender G384”, page 203](#)

### 7.1 General points

The functions of the anti-theft warning system are integrated in the vehicle voltage control unit - J519- .

After replacing the vehicle voltage control unit - J519- , the anti-theft warning system must be adapted with ⇒ Vehicle diagnostic tester.

Description of the function ⇒ Owner's manual Yeti .

#### Fault recognition and fault display

The anti-theft warning system is equipped with self-diagnosis, which facilitates the troubleshooting.

For fault finding use the ⇒ Vehicle diagnostic tester in the function “Targeted fault finding”.



#### Note

- ◆ *After triggering the anti-theft warning system, the alarm source which is stored in the vehicle voltage control unit - J519- is output. For determining the alarm source, use the ⇒ Vehicle diagnostic tester in the function “reading measured value block”.*
- ◆ *Before assembly, the vehicle must be unlocked with the release button of the radio control receiver.*

### 7.2 Alarm horn - H12-



#### Note

- ◆ *The alarm horn has an emergency battery which cannot be replaced as a separate item.*
- ◆ *The function of the alarm horn can be checked with the final control diagnosis of the vehicle voltage control unit - J519- .*

#### Removing

- Switch off the ignition and all electrical components.
- Remove the right plenum chamber cover (on the left for right-hand drive) ⇒ Body Work; Rep. gr. 66 .

Protected by copyright. Copying for private or commercial purposes, in part or in whole, is not permitted unless authorised by ŠKODA AUTO A. S. ŠKODA AUTO A. S. does not guarantee or accept any liability with respect to the correctness of information in this document. Copyright by ŠKODA AUTO A. S. ©



- Unscrew screws -arrows- and remove cover -1-.
- Vehicles manufactured up to CW 22.2010:

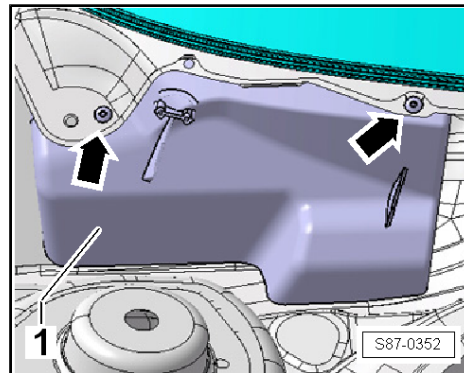

- Unscrew nuts -3- and remove alarm horn -2-.
- Disconnect plug.



**Note**

- ◆ The screw -1- must be bored out to remove the holder of the alarm horn.
- ◆ Before drilling out the screw, cover the air inlet cover of the heating and air conditioning unit and remove all the metal swarfs after boring out which result from the boring.
- ◆ Any damage to the paint work must be repaired immediately by a specialist.

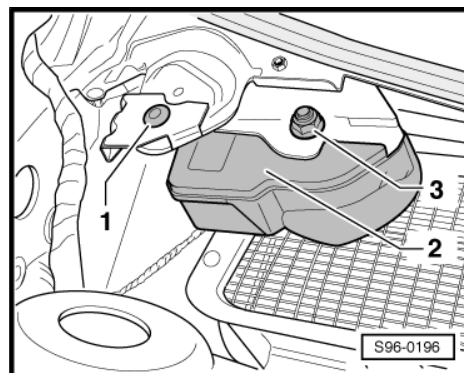

Vehicles manufactured as of CW 23.2010:

- Release nuts -1- and remove alarm horn with holder -2-.
- If necessary, detach alarm horn from bracket.
- Disconnect plug.

**Install**

Installation is performed in the reverse order, pay attention to the following points:

- The peg on the holder locks the correct position of the alarm horn to the holder.
- Vehicles manufactured up to CW 22.2010 - if the holder of the alarm horn is removed, then screw in a new pull-off screw -1- and tighten until the screw head shears off.
- Perform a functional test.

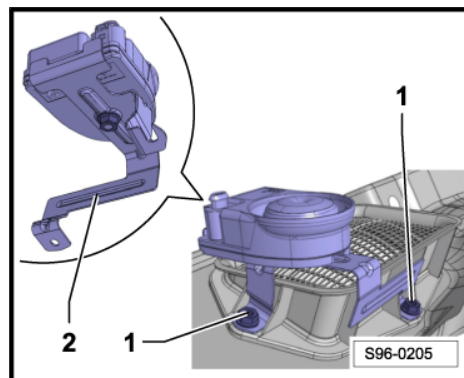

**Tightening torques**

Fixing screws for top cover	1.2 Nm
Fixing nuts for alarm horn to mounting bracket	5 Nm
Fixing nuts for bracket to body	3 Nm

**7.3 Removing and installing the contact switch for the bonnet - F266-**

**Removing**

- Switch off the ignition and all electrical components.
- Disconnect the plug for the contact switch which is located behind the centre lock carrier at the top.



- Remove the front flap lock ⇒ Body Work; Rep. gr. 55 , do not separate the control cable.
- Compress the stop -1- and move the bonnet contact switches - F266- in the elongated holes so that they can be removed.

**Install**

Installation is carried out in the reverse order.

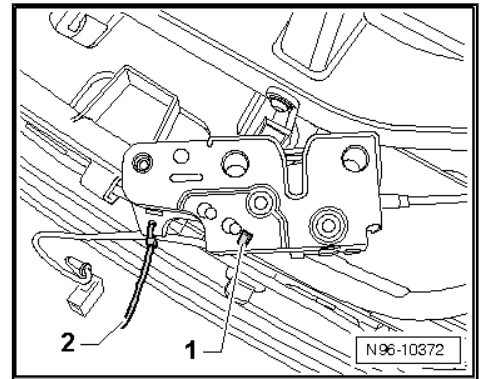

**7.4 Removing and installing interior monitoring deactivation switch - E267- and deactivation button for vehicle inclination sender - E360-**

You can find the information regarding the removal and installation of the interior monitoring deactivation switch - E267- and the deactivation button of the vehicle inclination sender - E360- in the ⇒ [“4.1 Removing and installing interior monitoring deactivation switch E267 and deactivation button for vehicle inclination sender E360”](#), page 195 .

**7.5 Removing and installing interior monitoring sensor - G273- and vehicle inclination sender - G384-**



**Note**

*The sensors for interior monitoring - G273- and the vehicle inclination sender - G384- form a building unit and cannot be replaced separately.*

**Removing**

- Switch off the ignition and all electrical components.
- Remove the interior light in the front roof cover ⇒ [“1.1 Removing and installing the front interior light”](#), page 187 .
- Release the sensors for interior monitoring -2- out of the bottom catches and release from the bracket by slightly tilting out arrows -B-.
- Press off the catches arrows -A- and remove the vehicle inclination sender -1- with sensors for interior monitoring -2- out of the interior light.

**Install**

Installation is carried out in the reverse order.

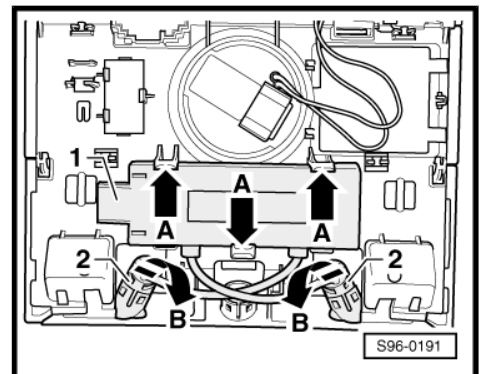



## 8 Horn

⇒ "8.1 Removing and installing high-tone horn and low-tone horn",  
page 204

### 8.1 Removing and installing high-tone horn and low-tone horn



#### Caution

*The tone pitch of the horn is set at the factory. It is prohibited to change this setting or to adjust the control screw!*

*If it is noticed that a screw is adjusted, the guarantee is no longer valid.*



#### Note

- ◆ *The horns are located at the front left and right next to the frame side rails behind the bumper.*
- ◆ *On vehicles for India, the horns are located at the lock carrier behind the radiator grill as of CW 32.2011.*

#### Remove (except vehicles for India as of CW 32.2011)

- Switch off the ignition and all electrical components.
- Remove the sound dampening system ⇒ Body Work; Rep. gr. 50 .
- Slacken the front part of the wheelhouse liner on the side of the horn to be removed ⇒ Body Work; Rep. gr. 66 .
- Vehicles with diesel engines, right side - slacken charge air hose.
- Unplug connector -arrow-.

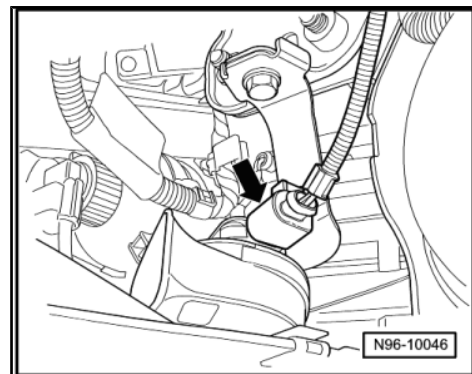

- Unscrew fixing screw -arrow- and remove horn with bracket.
- If necessary, detach bracket from horn.

### Tightening torques

Fixing screw for horn bracket to body	20 Nm
Fixing screw for horn to bracket	14 Nm

### Remove - vehicles for India as of CW 32.2011

- Open front flap and remove the radiator grill.
- Disconnect the plugs from the horns.
- Unscrew screws -2- and remove the bracket with horns.
- If necessary, unscrew the screws -1- and remove the horns from the shared holder.

### Install

Installation is carried out in the reverse order.

### Tightening torques

Screws, Pos. -2-	8 Nm
Screws, Pos. -1-	16 Nm

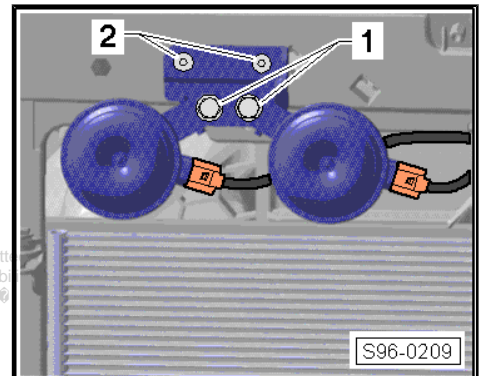
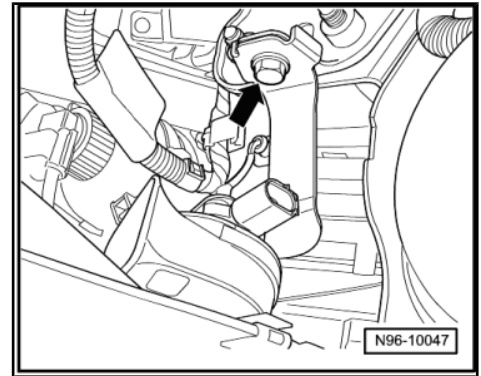



## 9 12V sockets

⇒ [“9.1 Removing and installing the 12 V socket in the centre console”, page 206](#)

⇒ [“9.2 Removing and installing the luggage compartment 12 V power socket”, page 207](#)

### 9.1 Removing and installing the 12 V socket in the centre console

Special tools and workshop equipment required

- ◆ Extractor - T40148-

Removing



Note

*For purposes of clearer presentation, the socket is shown as partly removed in the figure.*

- Switch off the ignition and all electrical components.
- Insert the extractor -T40148- in such a way that the retaining tabs lock into the recesses in the socket housing -arrow- at the extractor -2-.

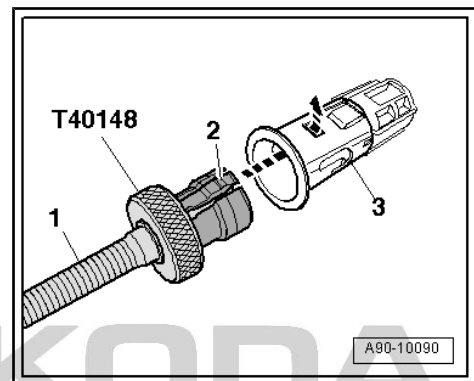

- After locking the retaining tabs, position the clamp -2- and turn with the knurled nut -1- -arrow-, until the socket -3- is completely pulled out of the centre console -4-.



Note

*Pay attention to the wiring length when pulling out the socket.*

- Disconnect plug.

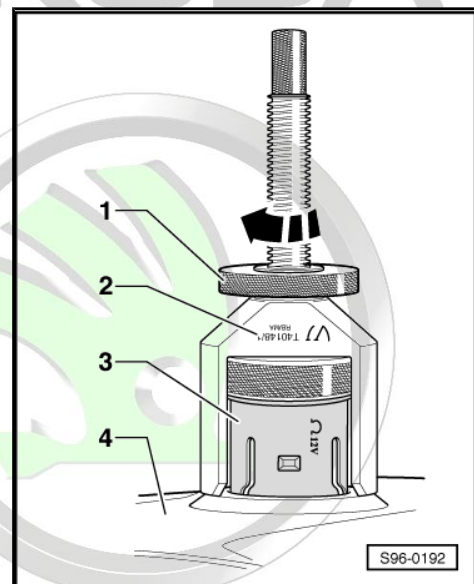



- Unscrew the knurled nut and push out the support bracket -1-.
- The retaining tabs -2- are unlocked by pressing on the spindle of the extractor and by turning -arrow- the knurled wheel -4-.
- Push the extractor out of the socket housing -3-.

**i Note**

*The retaining springs of the socket are pressed apart by inserting the extractor and the holding torque is reduced.*

- Carefully press together again the retaining springs of the socket -arrow-, in order to increase the holding torque.

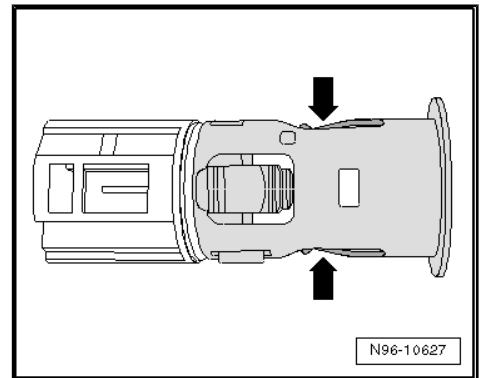
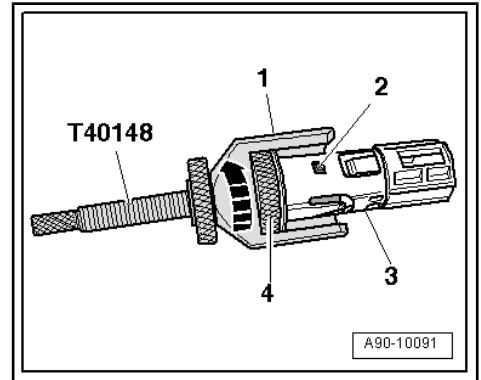

- Slacken the tensioning sleeve of the socket -1- out of the catch peg -2-, tilt out the tensioning sleeve -arrow- and remove it.

**Install**

- Insert the tensioning sleeve of the socket into the centre console until it clicks audibly into place.
- Place the connector onto the socket.
- Insert power socket into the tensioning sleeve up to the stop.
- Vehicles with cigarette lighter - check the cigarette lighter for proper function (after the preheating process, it remains in the removal position and is not hurled into the vehicle interior).

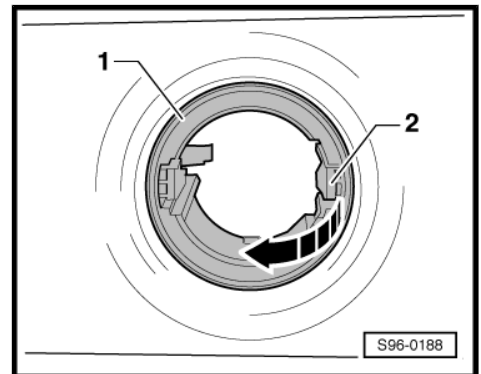

**9.2 Removing and installing the luggage compartment 12 V power socket**

- Switch off the ignition and all electrical components.
- Partly remove the right side trim panel in the luggage compartment -4- → Body Work; Rep. gr. 70 .
- Disconnect plug connection -1-.
- Remove nut -5-.
- Pull power socket -2- with socket -3- out of the trim panel -4-.

Installation is carried out in the reverse order.

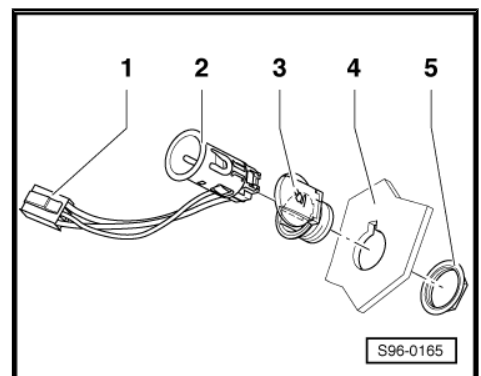



## 10 Immobiliser

⇒ ["10.1 General points", page 208](#)

⇒ ["10.2 Immobiliser control unit J362 ", page 208](#)

⇒ ["10.3 Adapting and checking the ignition key", page 209](#)

⇒ ["10.4 New identity when changing all the components", page 209](#)

⇒ ["10.5 System test result \(online connection\)", page 210](#)

### 10.1 General points

The model Yeti features the immobiliser of the fourth generation with on-line connection and Download. An essential component part of the immobiliser of the fourth generation is a central database, in which all theft-related data of the control units involved are stored. It is not possible to adapt the immobiliser control units without online connection to this database.

- ◆ A PIN code request of the immobiliser components by fax or temporary activation of the components is not possible.
- ◆ All the components of the immobiliser must be initialised on-line.
- ◆ All - even re-ordered - ignition keys are already precoded at the factory for a specific vehicle and can only be initialised for this vehicle.
- ◆ When re-ordering ignition keys, the relevant vehicle identification number must be provided.
- ◆ In Škoda vehicles it is no longer possible to adapt the components of other corporate brands.

#### Immobiliser components:

- Immobiliser control unit - J362-
- Ignition key
- Engine control unit - J623-
- ◆ Diesel engines ⇒ Engine; Rep. gr. 23
- ◆ Petrol engines ⇒ Engine; Rep. gr. 24

Further information and description of the individual components  
 ⇒ Self-study programme No. 87 ; Immobilisers in Škoda vehicles .

#### Functions of the immobiliser control unit - J362- :

- ◆ Communication between all the immobiliser components
- ◆ Encryption of data between the control units involved

#### Fault recognition and fault display

The immobiliser is equipped with self-diagnosis, which facilitates the fault finding.

For fault finding, use the ⇒ Vehicle diagnostic tester in the mode "Targeted fault finding".

### 10.2 Immobiliser control unit - J362-

The immobiliser control unit - J362- is integrated in the dash panel insert. If the control unit is defective, the complete dash panel insert must be replaced.

### Adapt immobiliser control unit - J362-

- Connect ⇒ Vehicle diagnostic tester.
- Select the operating mode "Targeted fault-finding" in the ⇒ Vehicle diagnostic tester.
- Select the "Selected Functions/Components" and subsequently the following menu points using the button "Skip":
  - ◆ Body
  - ◆ Electrical System
  - ◆ 01 - Self-diagnosable systems
  - ◆ Immobiliser
  - ◆ Operation
  - ◆ Adjust dash panel insert

## 10.3 Adapting and checking the ignition key



### Note

- ◆ *All - even re-ordered - ignition keys are already precoded at the factory for a specific vehicle and can only be adapted to this vehicle.*
- ◆ *When re-ordering ignition keys, the relevant vehicle identification number must be provided and subsequently the new keys must be adapted to the immobiliser control unit - J362-.*
- ◆ *If new or additional ignition keys are required, they must be adapted to the immobiliser control unit.*
- ◆ *Before replacing the lock set or the control units, the function "New identity when changing all the components" must be retrieved.*

Adapt the ignition key to the immobiliser control unit - J362- or check:

- Connect ⇒ Vehicle diagnostic tester.
- Select the operating mode "Targeted fault-finding" in the ⇒ Vehicle diagnostic tester.
- Select the "Selected Functions/Components" and subsequently the following menu points using the button "Skip":
  - ◆ Body
  - ◆ Electrical System
  - ◆ 01 - Self-diagnosable systems
  - ◆ Immobiliser
  - ◆ Operation

### ◆ Adapt and check the ignition key

## 10.4 New identity when changing all the components

All necessary steps required for the new installation of all the immobiliser components are carried out with this programme.

- Connect ⇒ Vehicle diagnostic tester.
- Select the operating mode "Targeted fault-finding" in the ⇒ Vehicle diagnostic tester.



- Select the “Selected Functions/Components” and subsequently the following menu points using the button “Skip”:
- ◆ Body
- ◆ Electrical System
- ◆ 01 - Self-diagnosable systems
- ◆ Immobiliser
- ◆ Operation
- ◆ New identity

## 10.5 System test result (online connection)

The following steps are carried out with this test programme:

- ◆ System test for the online connection
- ◆ Verification of user authorisation
- ◆ Test of the correct cable connection to the ŠKODA database

The precondition for this is the online connection (network connection) of the tester.

- Connect ⇒ Vehicle diagnostic tester.
- Select the operating mode “Targeted fault-finding” in the ⇒ Vehicle diagnostic tester.
- Select the “Selected Functions/Components” and subsequently the following menu points using the button “Skip”:

- ◆ Body
- ◆ Electrical System
- ◆ 01 - Self-diagnosable systems
- ◆ Immobiliser
- ◆ Operation
- ◆ Online system test

ŠKODA

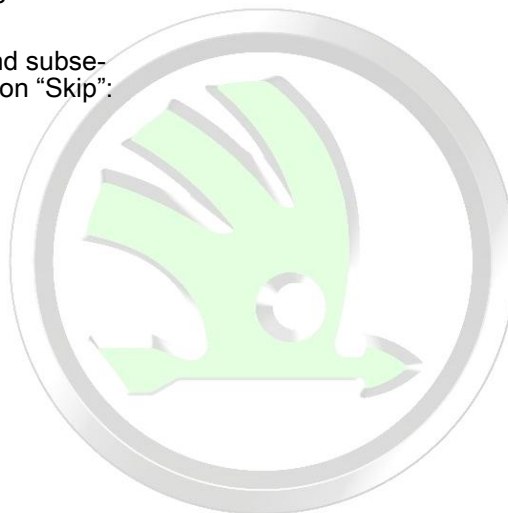

Protected by copyright. Copying for private or commercial purposes, in part or in whole, is not permitted unless authorised by ŠKODA AUTO A. S. ŠKODA AUTO A. S. does not guarantee or accept any liability with respect to the correctness of information in this document. Copyright by ŠKODA AUTO A. S. ©



## 97 – Wiring

### 1 Fuse holder and relay carrier

⇒ [“1.1 Removing and installing fuse holder in the dash panel”, page 211](#)

⇒ [“1.2 Removing and installing the relay carrier below the vehicle voltage control unit J519”, page 212](#)

⇒ [“1.3 Removing and installing the relay carrier above the vehicle voltage control unit J519”, page 213](#)

⇒ [“1.4 Removing and installing the E-box in the engine compartment \(relay and fuse holder\)”, page 213](#)

#### 1.1 Removing and installing fuse holder in the dash panel



##### Note

*You can find the exact arrangement of the fuses and the relays in the fuse holder and the relay carrier ⇒ Current flow diagrams, Electrical fault finding and Fitting locations.*

##### Removing

- Disconnect battery earth strap  
⇒ [“1.1 Disconnecting and reconnecting battery”, page 5](#) .
- Insert the screwdriver in the recess -2-, lever out the side cover -1- -arrow- and remove from the dash panel.

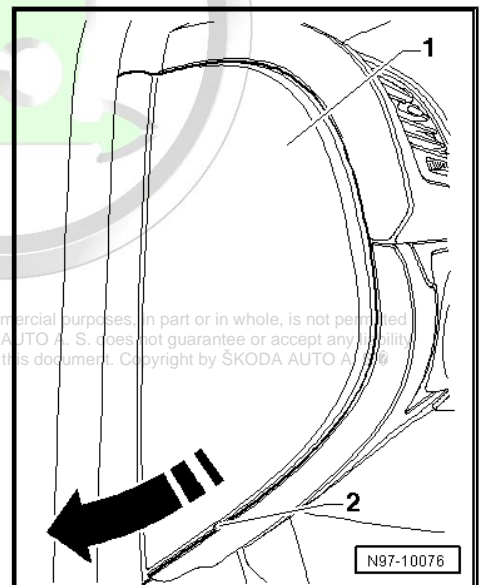

Protected by copyright. Copying for private or commercial purposes, in part or in whole, is not permitted unless authorised by ŠKODA AUTO A. S. ŠKODA AUTO A. S. does not guarantee or accept any liability with respect to the correctness of information in this document. Copyright by ŠKODA AUTO A. S.



- Remove the bottom part of the dash panel -1- on the driver's side ⇒ Body Work; Rep. gr. 70 .
- Unscrew fixing screws -arrows-, slacken the fuse holder -2- and unhook towards the bottom.

**Install**

Installation is performed in the reverse order, pay attention to the following points:

- Pay attention to the correct work sequence when connecting the battery ⇒ ["1.1 Disconnecting and reconnecting battery", page 5](#) .

**Tightening torques**

Fixing screws for fuse holder	3 Nm
-------------------------------	------

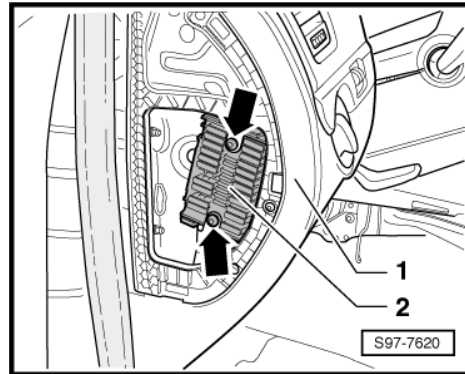

## 1.2 Removing and installing the relay carrier below the vehicle voltage control unit - J519-



**Note**

- ◆ *The assignment of the relay carrier depends upon the vehicle equipment.*
- ◆ *Exact assignment of the relay carrier ⇒ Current flow diagrams, Electrical fault finding and Fitting locations.*

**Removing**

- Disconnect battery earth strap ⇒ ["1.1 Disconnecting and reconnecting battery", page 5](#) .
- Remove lower part of the dash panel insert on the driver's side ⇒ Body Work; Rep. gr. 70 .
- Remove the knee airbag and its bracket ⇒ Body Work; Rep. gr. 69 .
- Press together the retaining tabs arrows -A- and push the relay carrier -1- with relays out of the brackets at the vehicle voltage control unit -2-.
- Take the relay out of the relay carrier.

**Install**

Installation is performed in the reverse order, pay attention to the following points:

- Pay attention to the work sequence when connecting the battery ⇒ ["1.1 Disconnecting and reconnecting battery", page 5](#) .

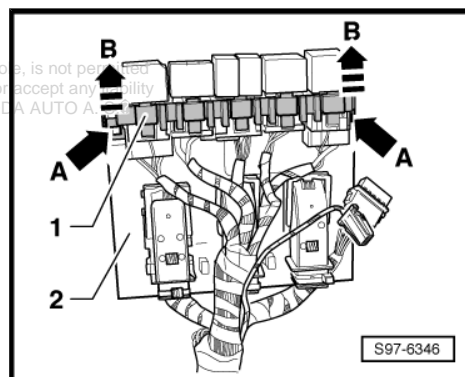

### 1.3 Removing and installing the relay carrier above the vehicle voltage control unit - J519-

**i** Note

- ◆ *The assignment of the relay carrier depends upon the vehicle equipment.*
- ◆ *Exact assignment of the relay carrier ⇒ Current flow diagrams, Electrical fault finding and Fitting locations.*

#### Removing

- Disconnect battery earth strap  
 ⇒ ["1.1 Disconnecting and reconnecting battery", page 5](#) .
- Remove onboard control unit - J519-  
 ⇒ ["2.1 Onboard supply control unit J519", page 217](#) .
- Press the retaining lugs at the positions shown by the arrows -A- and tilt out relay carrier -3- in direction of arrow -B- and slide together from the holder -2- in direction of arrow -C-.
- Unhook the relay carrier towards the bottom or take it out and replace the defective relay.

#### Install

Installation is performed in the reverse order, pay attention to the following points:

- Pay attention to the work sequence when connecting the battery ⇒ ["1.1 Disconnecting and reconnecting battery", page 5](#) .

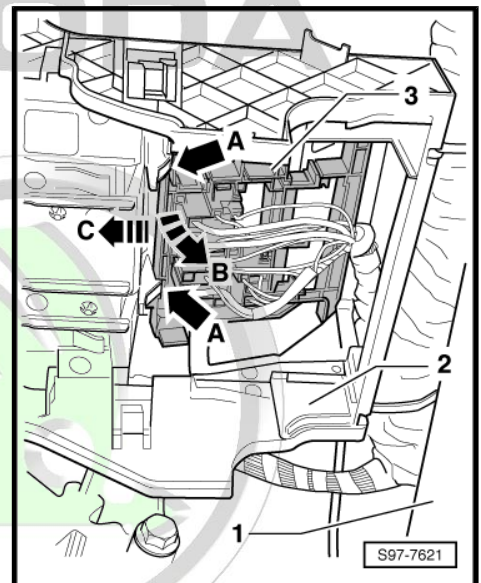

### 1.4 Removing and installing the E-box in the engine compartment (relay and fuse holder)

Protected by copyright. Copying for private or commercial purposes, in part or in whole, is not permitted unless authorised by ŠKODA AUTO A. S. ŠKODA AUTO A. S. does not guarantee or accept any liability with respect to the correctness of information in this document. Copyright by ŠKODA AUTO A. S. ©

**i** Note

- ◆ *The number of plug connections, fuses, relays and connections can vary depending on the vehicle equipment. The assembly work is identical.*
- ◆ *The exact assignment of the plugs, fuses, relays and connections ⇒ Current flow diagrams, Electrical fault finding and Fitting locations.*

#### Removing

- Remove the battery  
 ⇒ ["1.4 Removing and installing the battery", page 7](#) .



- Slide the catch clamp -arrows- and take the cover for the E-box out towards the top.

**i** Note

*If the connection cables -1- are disconnected, mark their fitting location for an easier installation at a later stage.*



- Unscrew the nuts -1-.
- Open the cover -3- of the cable guide on the E box -arrow-.
- Remove the cables from the connecting bolts.
- Remove the cables from the guides.

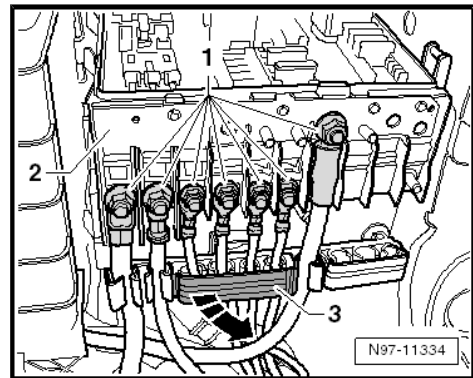
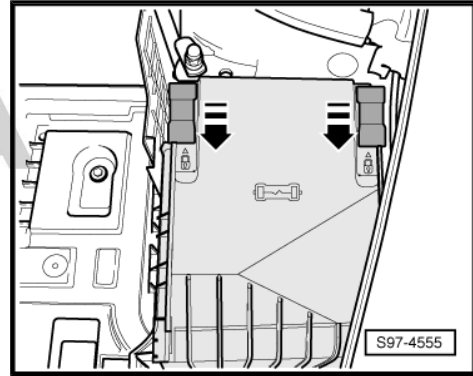
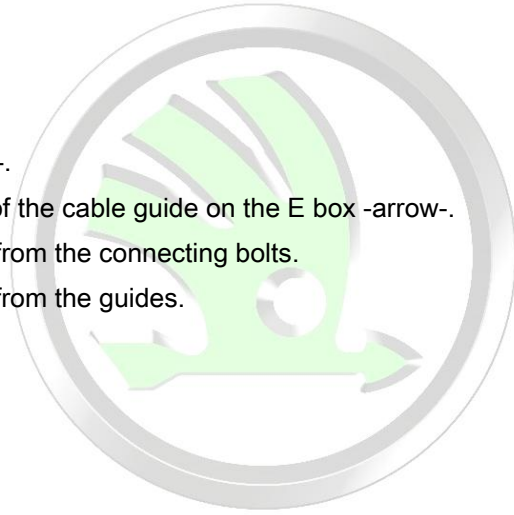

- Unscrew centre screw -arrow-.

**i** Note

*By screwing out the central fixing screw -arrow-, the E-box -1- is pressed towards the top by the E-box holder.*

- Remove the E-box -1- from the holder upwards.

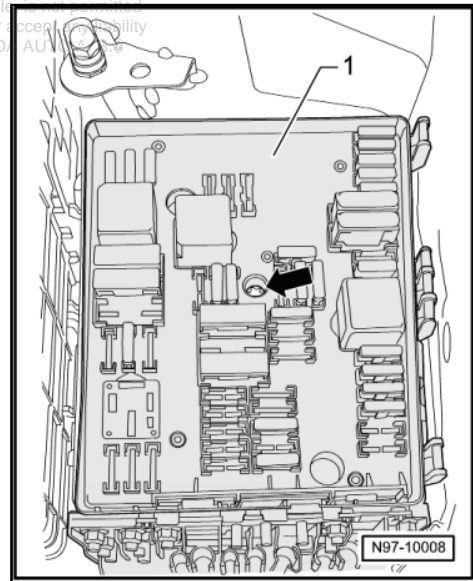



- Press the locking lugs on the E-box holder in direction of arrow -B- and move flat connector -1- from the E-box holder in direction of arrow -A-.

# ŠKODA

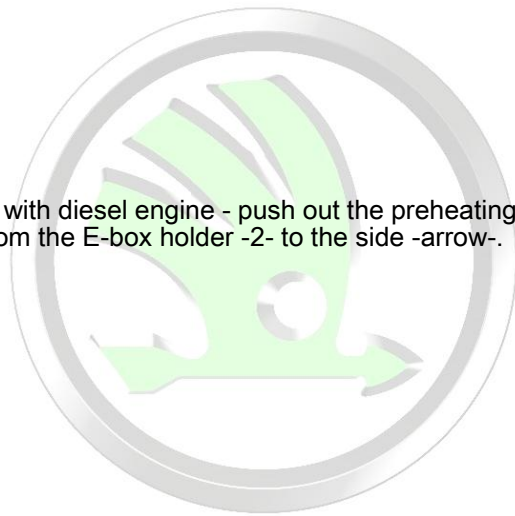

- Vehicles with diesel engine - push out the preheating time relay -2- from the E-box holder -2- to the side -arrow-.

Protected by copyright. Copying for private or commercial purposes, in part or in whole, is not permitted unless authorised by ŠKODA AUTO A. S. ŠKODA AUTO A. S. does not guarantee or accept any liability with respect to the correctness of information in this document. Copyright by ŠKODA AUTO A. S. ©

- Unscrew fixing nuts -arrows- and take out the E-box holder -1-.

### Install

Installation is performed in the reverse order, pay attention to the following points:

### Note

*On vehicles where there is a label on the cover of the E box with a note indicating the required change of the multiple fuse -2-, this fuse must be replaced when loosening the nuts -1-.*

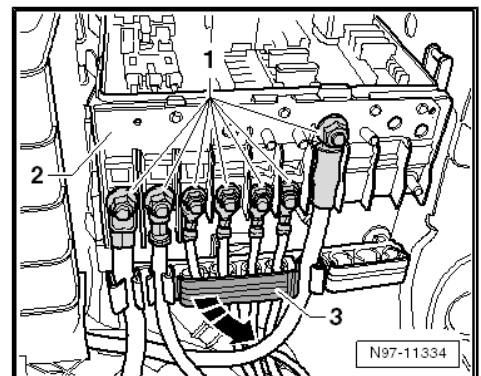
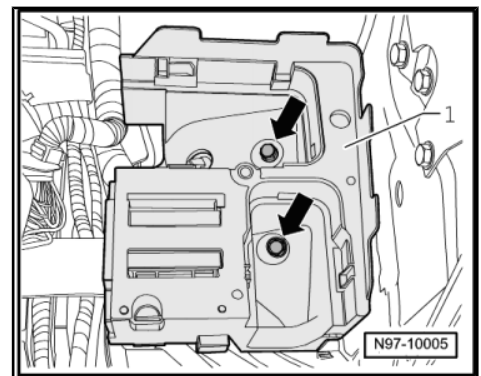
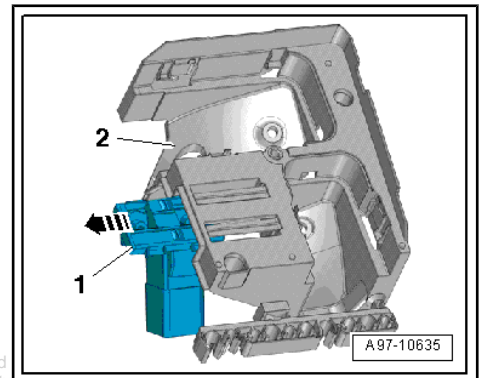
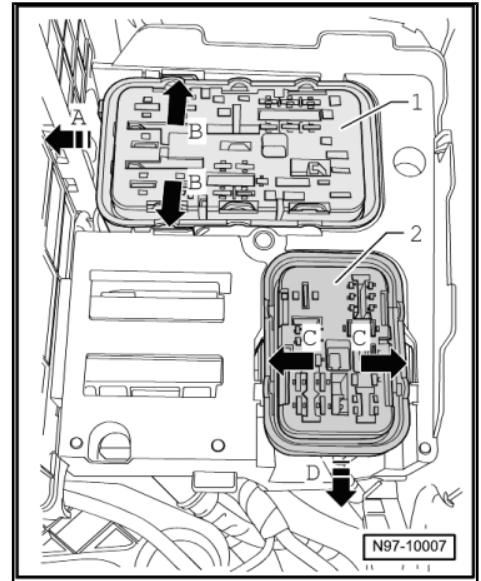



- Position the cover -2- on the E-box and move the catch clamp -1- in direction of arrow -arrows- until the cover is locked. Subsequently check the cover for tight locking.
- Pay attention to the work sequence when connecting the battery ⇒ ["1.1 Disconnecting and reconnecting battery", page 5](#).

**Tightening torques**

M5 fixing nut for cable	4.5 Nm
M6 fixing nut for cable	6 Nm
Fixing screw for E-box	9 Nm
Fixing nuts for E-box holder	9 Nm

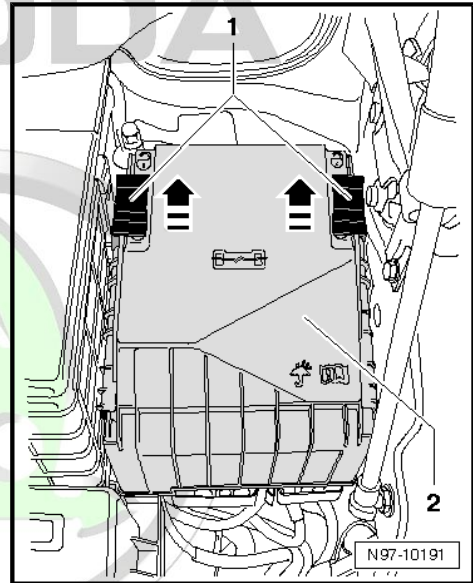

Protected by copyright. Copying for private or commercial purposes, in part or in whole, is not permitted unless authorised by ŠKODA AUTO A. S. ŠKODA AUTO A. S. does not guarantee or accept any liability with respect to the correctness of information in this document. Copyright by ŠKODA AUTO A. S. ©

## 2 Control units

⇒ [“2.1 Onboard supply control unit J519”, page 217](#)

⇒ [“2.2 Data bus diagnostic interface Gateway J533”, page 218](#)

### 2.1 Onboard supply control unit - J519-

⇒ [“2.1.1 General description”, page 217](#)

⇒ [“2.1.2 Fault recognition and fault display”, page 217](#)

⇒ [“2.1.3 Removing and installing the vehicle voltage control unit J519”, page 217](#)

#### 2.1.1 General description

The vehicle voltage control unit - J519- (BCM) communicates with other control units via the data buses CAN bus, its own data buses LIN bus and data interface GATEWAY and controls the convenience functions of the vehicle.

If the vehicle voltage control unit - J519- is replaced, the new control unit must be coded.

For carrying out the coding, the ⇒ Vehicle diagnostic tester must be connected on-line (network connection).

After the replacement (depending on equipment) the functions of the control unit such as “remote control for central locking”, “anti-theft warning system”, etc. must be adapted.

Other information:

- ◆ ⇒ Self-study programme No. 66 ; (the vehicle voltage control unit is similar as for Superb II)
- ◆ ⇒ Vehicle diagnostic tester
- ◆ ⇒ Current flow diagrams, Electrical fault finding and Fitting locations

#### 2.1.2 Fault recognition and fault display

The onboard supply control unit - J519- is equipped with self-diagnosis, which facilitates the fault finding.

For fault finding use the ⇒ Vehicle diagnostic tester in the function “Targeted fault finding”.

#### 2.1.3 Removing and installing the vehicle voltage control unit - J519-

##### Removing

The control unit is located behind the left dash panel on the driver side.

- Disconnect battery earth strap  
⇒ [“1.1 Disconnecting and reconnecting battery”, page 5](#) .



- Remove the bottom part of the dash panel -1- on the driver's side ⇒ Body Work; Rep. gr. 70 .
- Remove the knee airbag and its bracket ⇒ Body Work; Rep. gr. 69 .
- Unclip the relay carrier below the vehicle voltage control unit - J519-  
⇒ ["1.2 Removing and installing the relay carrier below the vehicle voltage control unit J519"](#), page 212 and unhook towards the bottom.
- For unplugging the plugs -2-, successively press together the catches on the plug connections and remove the plugs on the control unit by swivelling out the clamp.
- Unhook the pulled-out plugs towards the bottom.
- Press together the catches in direction of arrow -A-, slightly tilt out the control unit arrow -B- and push out of the bearing in the bracket arrow -C-.

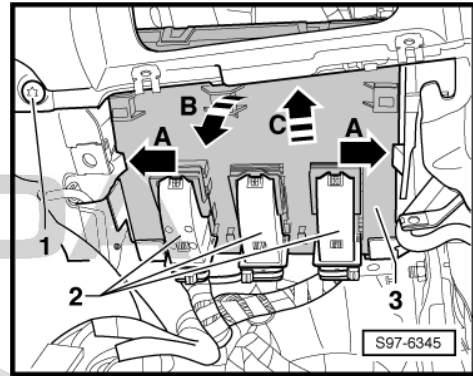

### Install

Installation is performed in the reverse order, pay attention to the following points:

- Insert the control unit and correctly lock into the holder.
- Pay attention to the work sequence when connecting the battery ⇒ ["1.1 Disconnecting and reconnecting battery"](#), page 5 .



### Note

- ◆ *If the vehicle voltage control unit - J519- is replaced, the new control unit must be coded.*
- ◆ *For carrying out the coding, the ⇒ Vehicle diagnostic tester must be connected on-line (network connection).*
- ◆ *After the replacement and the coding (depending on equipment) the functions of the control unit such as "remote control for central locking", "anti-theft warning system", etc. must be adapted.*

## 2.2 Data bus diagnostic interface Gateway - J533-

⇒ ["2.2.1 General description"](#), page 218

⇒ ["2.2.2 Remove and install data bus diagnostic interface Gateway J533."](#), page 219

⇒ ["2.2.3 Contact assignment data bus diagnostic interface Gateway J533"](#), page 220

### 2.2.1 General description

The diagnostic interface for the Gateway databus -J533- serves to link different CAN bus systems in the vehicle. It transmits data e.g. from the engine control unit (CAN bus drive) to the dash panel insert (dash panel insert CAN bus).

The data bus diagnostic interface Gateway -J533- is monitored by the self-diagnosis and can be tested with the ⇒ Vehicle diagnostic tester in the function "Targeted fault finding".

Check the databus activity - by doing this test you can notice if each databus (drive, comfort and infotainment) can switch over into the databus resting position (Sleep Mode).

Check the system at the databus - by doing this test the connection level of the data bus diagnostic interface to the other system can be checked for data bus.

## 2.2.2 Remove and install data bus diagnostic interface Gateway - J533- .

### Note

- ◆ *If the data bus diagnostic interface Gateway - J533- is replaced, it must be connected before the removal ⇒ Vehicle diagnostic tester and the function "replace data bus diagnostic interface" must be selected in the targeted fault finding for reading the codes stored in the control unit.*
- ◆ *The coding can also be performed via an on-line connection.*
- ◆ *If the original data bus diagnostic interface Gateway - J533- is not available or does not communicate with the diagnostic unit, then proceed according to the information in the ⇒ Vehicle diagnostic tester.*

### Remove - left-hand drive

The data bus diagnostic interface Gateway - J533- is located on the strut above the brake pedal.

- Switch off all electrical components and take out the ignition key.
- Remove the bottom part of the dash panel -1- on the driver's side ⇒ Body Work; Rep. gr. 70 .
- Removing the left footwell vent on the driver side ⇒ Heating, Air Conditioning; Rep. gr. 80 .
- Remove the driver knee airbag and its bracket ⇒ Body Work; Rep. gr. 69 .
- Press together the fixing pins -3- -arrows- and remove the control unit -2- from the openings in the bracket.
- Unhook the diagnostic interface -2- downwards and disconnect plug -1-.

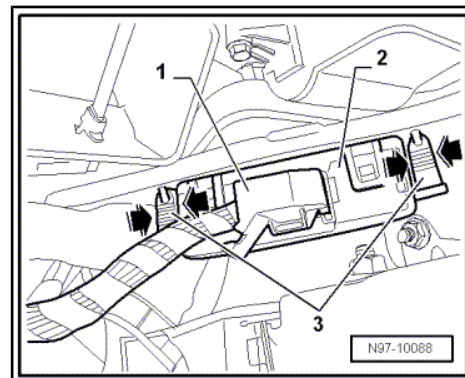

### Remove - right-hand drive

The data bus diagnostic interface Gateway - J533- is located behind the storage compartment of the front passenger side.

- Switch off all electrical components and take out the ignition key.
- Remove the storage compartment in the dash panel on the front passenger side ⇒ Body Work; Rep. gr. 70 .
- Unlock the plug connection -3- and disconnect.

- Press together the fixing pins -3- -arrows- and remove the control unit -1- from the openings in the bracket -2-.

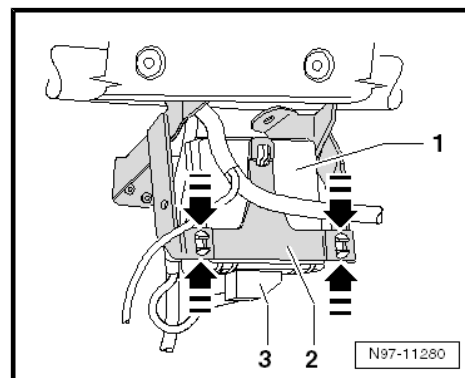

### Install

Installation is carried out in the reverse order.



### 2.2.3 Contact assignment data bus diagnostic interface Gateway - J533-

- 1 - Battery "+" (terminal 30)
- 2 - not assigned
- 3 - not assigned
- 4 - not assigned
- 5 - Convenience CAN bus Low
- 6 - Drive CAN bus Low
- 7 - not assigned
- 8 - Dash panel insert CAN bus Low
- 9 - Diagnosis CAN bus Low
- 10 - Infotainment CAN bus Low
- 11 - Earth "-" (terminal 31)
- 12 - not assigned
- 13 - Dash panel insert time input
- 14 - Terminal 15
- 15 - Convenience CAN bus High
- 16 - Drive CAN bus High
- 17 - not assigned
- 18 - Dash panel insert CAN bus High
- 19 - Diagnosis CAN bus High
- 20 - Infotainment CAN bus High

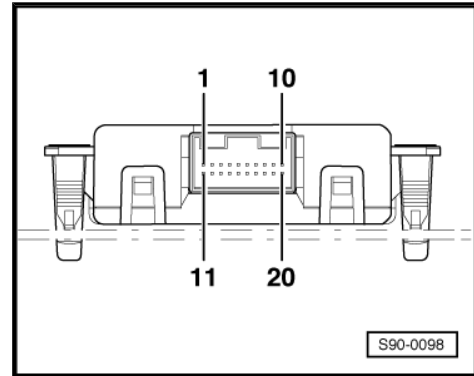

Protected by copyright. Copying for private or commercial purposes, in part or in whole, is not permitted unless authorised by ŠKODA AUTO A. S. ŠKODA AUTO A. S. does not guarantee or accept any liability with respect to the correctness of information in this document. Copyright by ŠKODA AUTO A. S. ©



### 3 Vehicle diagnosis, measurement and information systems

All the notes and comments for this chapter can be found under "Electrical System - General notes" → Electrical System - General notes; Rep. gr. 97 .

# ŠKODA



Protected by copyright. Copying for private or commercial purposes, in part or in whole, is not permitted unless authorised by ŠKODA AUTO A. S. ŠKODA AUTO A. S. does not guarantee or accept any liability with respect to the correctness of information in this document. Copyright by ŠKODA AUTO A. S. ©



## 4 Wiring harness repair

All the notes and comments for this chapter can be found under  
“Electrical System - General notes” ⇒ Electrical System - General  
notes; Rep. gr. 97 .



Protected by copyright. Copying for private or commercial purposes, in part or in whole, is not permitted unless authorised by ŠKODA AUTO A. S. ŠKODA AUTO A. S. does not guarantee or accept any liability with respect to the correctness of information in this document. Copyright by ŠKODA AUTO A. S. ©



## 5 Repairing socket housings and connectors

All the notes and comments for this chapter can be found under "Electrical System - General notes" → Electrical System - General notes; Rep. gr. 97 .



Protected by copyright. Copying for private or commercial purposes, in part or in whole, is not permitted unless authorised by ŠKODA AUTO A. S. ŠKODA AUTO A. S. does not guarantee or accept any liability with respect to the correctness of information in this document. Copyright by ŠKODA AUTO A. S.®



## 6 Repairing optical fibres

# ŠKODA

All the notes and comments for this chapter can be found under  
“Electrical System - General notes” → Electrical System - General  
notes; Rep. gr. 97 .



Protected by copyright. Copying for private or commercial purposes, in part or in whole, is not permitted unless authorised by ŠKODA AUTO A. S. ŠKODA AUTO A. S. does not guarantee or accept any liability with respect to the correctness of information in this document. Copyright by ŠKODA AUTO A. S. ©

## 7 Contact surface cleaning set - VAS 6410-

All the notes and comments for this chapter can be found under  
"Electrical System - General notes" → Electrical System - General  
notes; Rep. gr. 97 .

# ŠKODA



Protected by copyright. Copying for private or commercial purposes, in part or in whole, is not permitted unless authorised by ŠKODA AUTO A. S. ŠKODA AUTO A. S. does not guarantee or accept any liability with respect to the correctness of information in this document. Copyright by ŠKODA AUTO A. S. ©