

Workshop Manual YETI 2010 ➤

Automatic gearbox 0AM

Edition 12.09

ŠKODA



Protected by copyright. Copying for private or commercial purposes, in part or in whole, is not permitted unless authorised by ŠKODA AUTO A. S. ŠKODA AUTO A. S. does not guarantee or accept any liability with respect to the correctness of information in this document. Copyright by ŠKODA AUTO A. S. ©

List of Workshop Manual Repair Groups

ŠKODA

Repair Group

00 - Technical data

30 - Clutch

34 - Control, housing

35 - Wheels, shafts

39 - Final drive, differential gear



Protected by copyright. Copying for private or commercial purposes, in part or in whole, is not permitted unless authorised by ŠKODA AUTO A. S. ŠKODA AUTO A. S. does not guarantee or accept any liability with respect to the correctness of information in this document. Copyright by ŠKODA AUTO A. S. ©

Technical information should always be available to the foremen and mechanics, because their careful and constant adherence to the instructions is essential to ensure vehicle road-worthiness and safety. In addition, the normal basic safety precautions for working on motor vehicles must, as a matter of course, be observed.

All rights reserved.
No reproduction without prior agreement from publisher.

Contents

00 - Technical data	1
1 Technical Data for the Gearbox	1
1.1 Identification of the gearbox	1
1.2 Identification characters, aggregate assignment, ratios	1
1.3 Contents	2
1.4 Transmission System - Overview	2
2 Instructions for automatic gearbox DSG - 0AM	4
2.1 Notes on tow starting and towing	4
2.2 General repair information	4
2.3 Working with testing devices	8
2.4 Explanation of the terms used in this workshop manual	9
30 - Clutch	11
1 Removing and installing the double clutch	11
1.1 Remove double clutch	11
1.2 Adjust the positions of the engaging bearing for clutch "K 1 and K 2" - "old design"	15
1.3 Adjust the positions of the engaging bearing for clutch "K 1 and K 2" - "new design"	21
1.4 Install double clutch - "old design"	31
1.5 Install double clutch - "new design"	37
34 - Control, housing	44
1 Electric/electronic components and fitting locations of the automatic gearbox DSG - 0AM	44
2 Shift mechanism	48
2.1 Inspecting the gearshift mechanism	48
2.2 Inspecting and adjusting the selector lever control cable	49
2.3 Check operation of the ignition key anti-removal lock	51
2.4 Summary of components - Shift mechanism up to 05.09 ("old shifting")	52
2.5 Summary of components - Shift mechanism as of 06.09 ("new shifting")	54
2.6 Removing and installing the handle and cover for the shift mechanism	55
2.7 Removing and installing shift mechanism	57
2.8 Removing and installing the selector lever control cable	61
2.9 Emergency release of gearshift mechanism out of position "P"	65
2.10 Removing and installing the Tiptronic switch F189	66
2.11 Removing and installing selector lever lock solenoid N110	67
2.12 Removing and installing selector lever switch locked in P F319	67
2.13 Removing and installing the selector lever sensor control unit J587	67
2.14 Checking the plug connections at the gearshift mechanism	67
3 Mechatronics for double clutch gearbox J743	68
3.1 Safety instruction for ^o mechatronics for double clutch gearbox J743	68
3.2 Summary of components - mechatronics for double clutch gearbox J743	69
3.3 Removing mechatronics for double clutch gearbox J743 ; gearbox removed.	69
3.4 Remove mechatronics for double clutch gearbox J743 ; gearbox installed.	73
3.5 Place the mechatronics for double clutch gearbox J743 by hand in the "removal position"	79
3.6 Installing mechatronics for double clutch gearbox J743 ; gearbox removed.	81
3.7 Install mechatronics for double clutch gearbox J743 ; gearbox installed	86
4 Removing and installing the gearbox	93
4.1 Removing the gearbox	93
4.2 Installing the gearbox	100
5 Transport the gearbox and secure to the assembly support	104
6 Change gearbox oil	106



35 - Wheels, shafts	109
1 Pinions and shafts	109
39 - Final drive, differential gear	110
1 Replace gasket rings for rigid shafts and flange shafts	110
1.1 Summary of components - Gasket rings and rigid shaft	110
1.2 Replacing left rigid shaft gasket ring	111
1.3 Replacing right rigid shaft gasket ring	114
1.4 Replacing the left flange shaft gasket ring	117
1.5 Replacing the right flange shaft seal ring	119

ŠKODA



Protected by copyright. Copying for private or commercial purposes, in part or in whole, is not permitted unless authorised by ŠKODA AUTO A. S. ŠKODA AUTO A. S. does not guarantee or accept any liability with respect to the correctness of information in this document. Copyright by ŠKODA AUTO A. S. ©



00 – Technical data

1 Technical Data for the Gearbox

1.1 Identification of the gearbox

The “7-speed automatic gearbox DSG - 0AM” is installed in combination with 4-cylinder engines. Assignment => [page 1](#) .

Location of identification code letters on the gearbox

Example for a gearbox:

The gearbox code letter -arrow- is located at the top and bottom of the gearbox.

- ◆ KHP = gearbox identification character
- ◆ 15.01.08 = Production date 15th January 2008
- ◆ 14 = manufacturer code
- ◆ 09:49 = time
- ◆ 0042 = serial number

The gearbox identification characters also appear on the vehicle data stickers.



Note

If these vehicle data stickers are not present and another gearbox is installed than the one intended or you have no other possibility to identify the installed gearbox in case of doubt, then read off the identification characters directly from the gearbox.

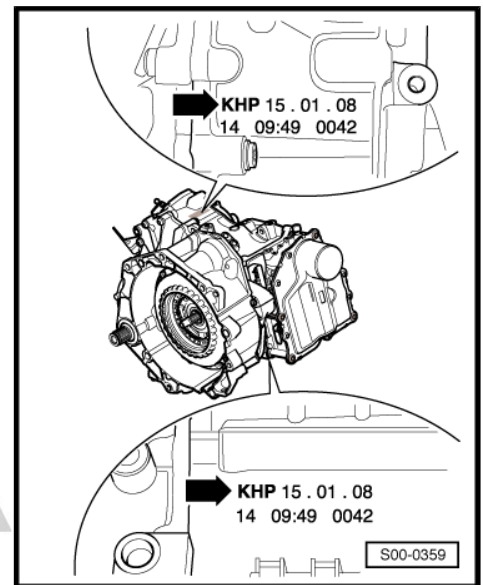

1.2 Identification characters, aggregate assignment, ratios

Automatic gearbox DSG		0AM “front-wheel drive”		
Gearbox	Identification characters	MGU	MLJ	MPQ
	Manufactured from through h	02.10 05.10	06.10 10.10	11.10
Assignment	Engine	1.2 ltr./77 kW TFSI		
Ratio: Z 2 : Z 1	Final drive for 1st gear through 4th gear	71 : 16 = 4,437		
	Final drive for 5th 6th and 7th gears	71 : 22 = 3,227		
	Final drive for reverse gear	71 : 17 = 4,176		
Ratios	1st gear	64 : 17 = 3,765		
	2nd gear	50 : 22 = 2,273		
	3rd gear	49 : 32 = 1,531		
	4th gear	46 : 41 = 1,122		
	5th gear	40 : 34 = 1,176		
	6th gear	39 : 41 = 0,951		
	7th gear	35 : 44 = 0,795		
	Reverse gear	45 : 22 x 53 : 26 = 4,169		



Automatic gearbox DSG		0AM "front-wheel drive"		
Gearbox	Identification characters	MGU	MLJ	MPQ
itot. in the highest gear		2,565		

1.3 Contents

The "7-speed automatic gearbox DSG - 0AM" has 2 separate, different oil fillings. One for the area with gearbox oil -arrow A- and the other one for the area with hydraulic oil -arrow B-.

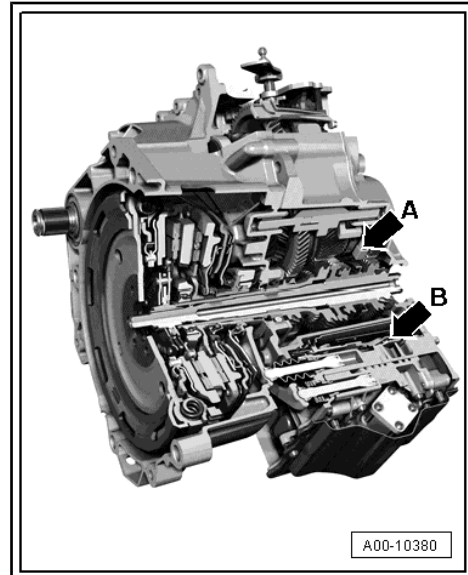

ŠKODA

Gearbox capacity	Area with gearbox oil
New filling	1.7 ltr.
Top-up	no top-up
Lubricant	Gearbox oil for direct manual gearbox 0AM part number => Electronic Catalogue of Original Parts

Capacity in the mechatronics for double clutch gearbox -J743-	Area with hydraulic oil
Filling	1 ltr.
Top-up	no top-up
<p>◆ The mechatronics is allocated according to the gearbox code letters => Electronic Catalogue of Original Parts . unless authorised by ŠKODA AUTO A. S. ŠKODA AUTO A. S. does not guarantee or accept any liability with respect to the correctness of information in this document. Copyright by ŠKODA AUTO A. S. ©</p> <p>◆ The "new" mechatronics for the gearbox is already precisely filled with oil at the factory.</p>	

Only spare part gear oils should be used for the "7-speed automatic gearbox DSG - 0AM". Other oils can lead to functional problems or to failure of the gearbox.

1.4 Transmission System - Overview

The "7-speed automatic gearbox DSG - 0AM" has 2 drive shafts and 3 output shafts.

- A1 - 1st drive shaft
- A2 - 2nd drive shaft
- B1 - 1st output shaft
- B2 - 2nd output shaft
- B3 - 3rd output shaft
- C - Front final drive
- K1 - Clutch 1
- K2 - Clutch 2
- M - Engine
- T1 - One part of the gearbox 1
 - with 1st, 3rd, 5th and 7th gear
- T2 - One part of the gearbox 2
 - with 2nd, 4th, 6th gear and reverse gear R

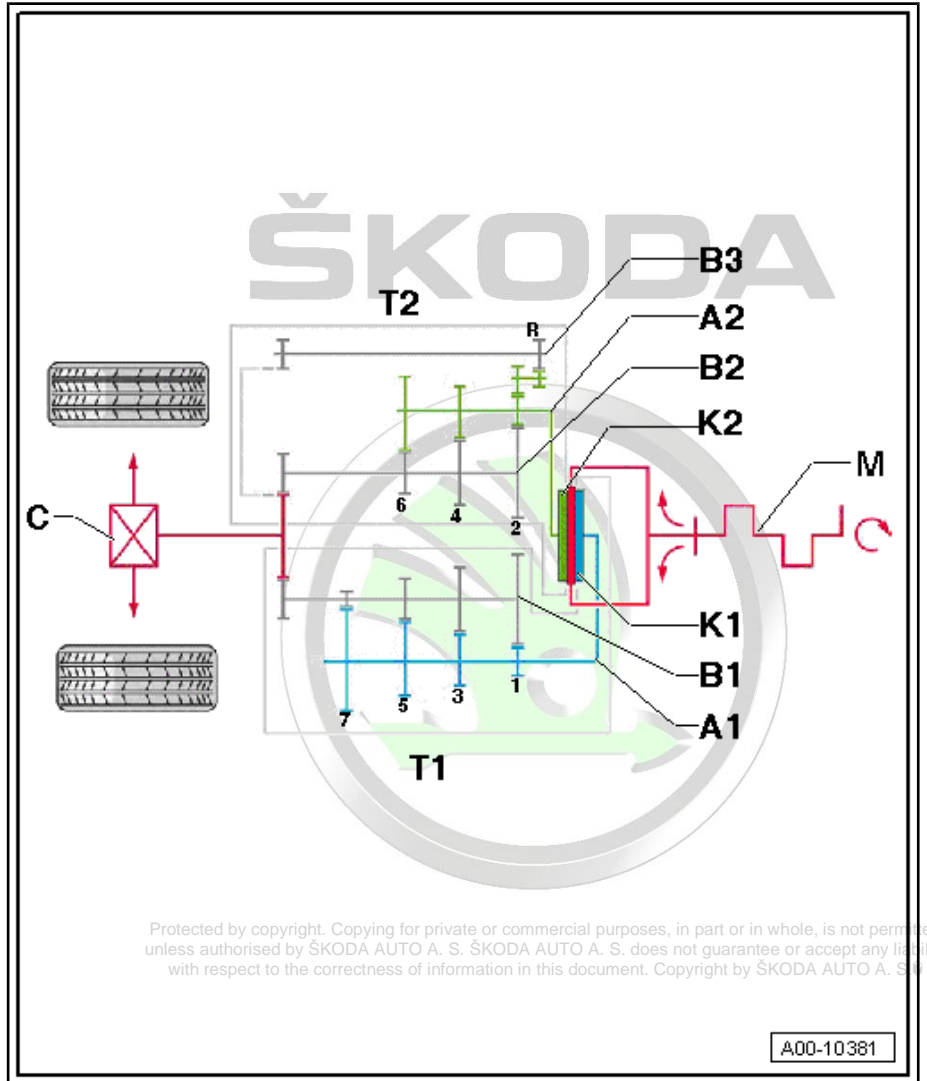



2 Instructions for automatic gearbox DSG - 0AM

The automatic gearbox DSG[®]-0AM is also designated as double clutch gearbox. The gearbox is built like a 7-speed manual gearbox.

2.1 Notes on tow starting and towing



Caution

When towing the vehicle, the selector lever must be in position "N" and it must not be towed further than 50 km and faster than 50 km/h, otherwise the gearbox will be destroyed.



Note

It is not possible to tow start an engine, e.g. if the battery is weak or the starter does not operate.

2.2 General repair information

Scrupulous care and cleanliness as well as the proper tools are essential requirements for carrying out proper and successful gearbox repairs. Obviously, the generally valid basic safety rules apply to repair work.

A number of generally valid notes for individual repair operations - which are otherwise listed several times at numerous points in the workshop manual - are summarized here. They apply to this workshop manual.

Special tools

List of the special tools used in the workshop manual is detailed in the individual repair descriptions.

Overview of components of the gearbox

- 1 - Ventilation cap of the gearbox
- 2 - Remove the cover "to the gearbox oil filling"
- 3 - Gearshift lever
- 4 - Ventilation cap of the mechatronics for double clutch gearbox -J743-
- 5 - Mechatronics for double clutch gearbox -J743-
- 6 - Double clutch
- 7 - Up to production date "11.08" rigid shaft ⇒ [page 5](#) , as of production date "11.08" flange shaft ⇒ [page 5](#)
- 8 - Oil drain plug, 30 Nm
- 9 - Automatic Gearbox DSG - 0AM

Gearbox

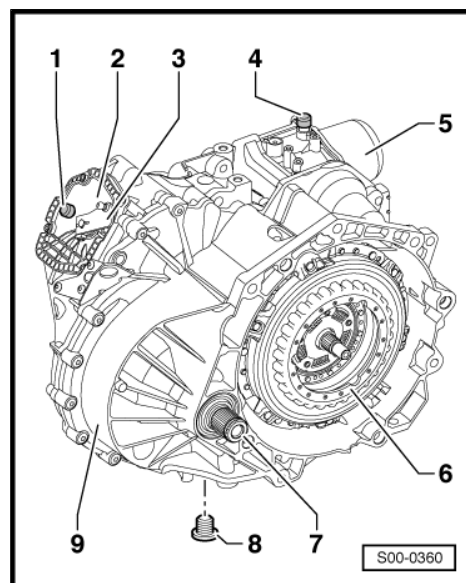



Gearbox with different output shafts

- ◆ -A- up to 11.08 - rigid shaft
- ◆ -B- as of 11.08 - flange shaft

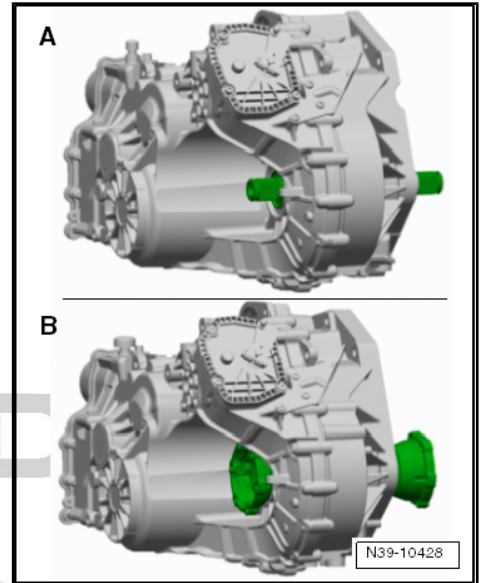

ŠKODA

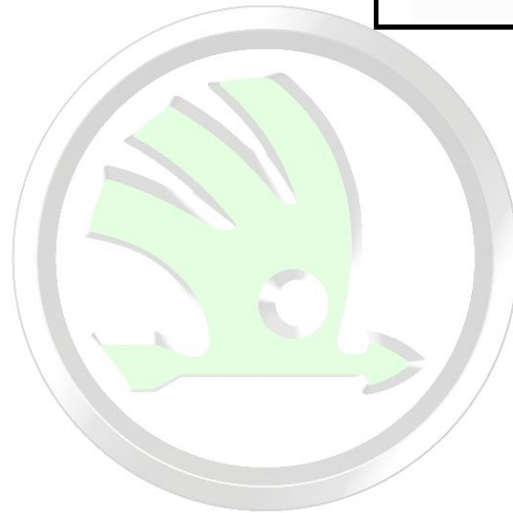

Protected by copyright. Copying for private or commercial purposes, in part or in whole, is not permitted unless authorised by ŠKODA AUTO A. S. ŠKODA AUTO A. S. does not guarantee or accept any liability with respect to the correctness of information in this document. Copyright by ŠKODA AUTO A. S. ©



The gearbox has an opening in the housing -arrow-.



Note

- ◆ When installing pay attention that nothing falls into this opening.
- ◆ Cover the opening with a cloth before commencing installation work.
- ◆ If the covers are unscrewed from the gearbox or the gearbox is without oil, do not let the engine run and do not tow the vehicle.
- ◆ Permanently ensure that no dirt can get into the "opened" gearbox.
- ◆ Thoroughly clean the connection points and their surroundings and then release.
- ◆ When installing the gearbox, ensure the dowel sleeves are correctly located between the engine and gearbox.

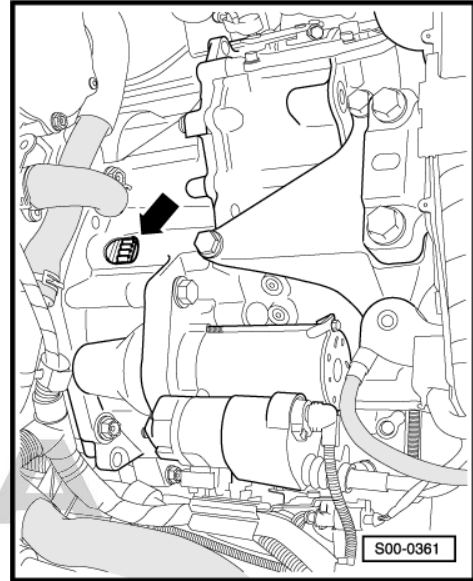

Mechatronics

- ◆ The mechatronics is allocated according to the gearbox code letters ⇒ Electronic Catalogue of Original Parts .
- ◆ The "new" mechatronics for the gearbox is already precisely filled with oil at the factory, do not drain the oil.
- ◆ The "removed" mechatronics for the gearbox is sent back with oil (close the ventilation opening with a suitable plug).

Gaskets, gasket rings, O-rings

- ◆ After removing gaskets, examine the contact surface in the housing or on shafts for burrs or damage, and correct if necessary.
- ◆ Before a radial shaft seal is installed, coat the sealing lips and the space in-between with sealing grease -G 052 128 A1- .
- ◆ The open side of the sealing rings is turned towards the oil.
- ◆ Always replace O-rings, gasket rings and gaskets.
- ◆ Before inserting the O-rings coat with gear oil to prevent the rings being damaged during installation.
- ◆ After installing, check gear oil level ⇒ [page 106](#) .

Gear oil

The "7-speed automatic gearbox DSG - 0AM" has 2 separate, different oil fillings. One for the area with gearbox oil -arrow A- and the other one for the area with hydraulic oil -arrow B-.

The oil level cannot be checked. The adjustment of the gear oil level can only be achieved by changing the gear oil, for example if the gearbox leaks => [page 106](#) .



Caution

Pay particular attention when handling oil. Dispose of drained oil appropriately.

- ◆ Shake oil bottle before opening.
- ◆ Do not mix any additives in the oil, also do not fill in other oil.
- ◆ Drained oil must not be refilled.

Locking elements

- ◆ Do not over-extend the circlips, if necessary replace.
- ◆ Circlips must be positioned in the base of the groove.

Screws, nuts

- ◆ Slacken and tighten nuts and bolts for attaching covers and housings diagonally across.
- ◆ Tightening torques apply for non-oiled nuts and bolts.
- ◆ Clean the thread of the screws that are inserted with a locking agent with a wire brush. Insert bolts with locking agent -AMV 185 101 A1- .
- ◆ Clean all threaded holes into which self-locking bolts are inserted, using a thread tap to remove locking agent residues. Otherwise there is a risk that the bolts will shear at the next disassembling.
- ◆ Always replace the self-locking nuts and screws.

Electrical components

If you touch objects out of metal, it can happen that this can lead to an electrostatic discharge. The reason for this is the electrostatic charge of the human body. This electrostatic charge can lead to operational problems when touching the electrical components of the gearbox and the shift mechanism.

- Touch an earthed object - e.g. a water pipe or a lift platform - before working on the electrical components.
- Do not grab directly at the plug contacts.

Targeted fault-finding

Before repairing the gearbox try to determine the origin of the damage as accurately as possible using "targeted fault finding".

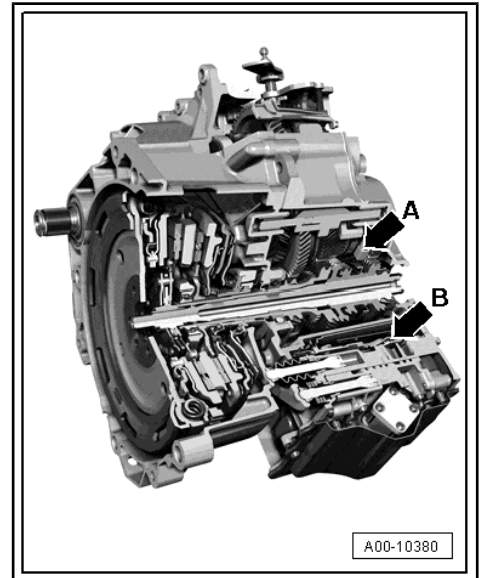



The “targeted fault finding” is performed with the ⇒ Vehicle diagnosis, testing and information system VAS 5051.

Rules of cleanliness

- ◆ Thoroughly clean the connection points and their surroundings before releasing.
- ◆ Only install clean parts: Remove spare parts from their wrapping immediately before installing.
- ◆ Always replace the paper gaskets. Completely remove old gasket and thoroughly clean sealing surfaces.
- ◆ Place removed parts on a clean surface and cover, so that they are not clogged up with dirt. Use foil and paper. Do not use fuzzy cloths!
- ◆ Carefully cover or seal opened or removed components if the repair is not carried out immediately.

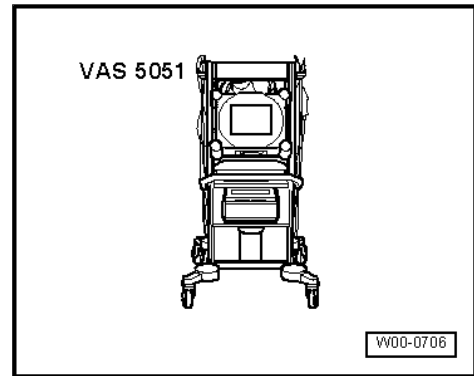

2.3 Working with testing devices

- ◆ Vehicle Diagnosis, Measurement and Information System - VAS 5052 A-
- ◆ Vehicle Diagnosis, Measurement and Information System - VAS 5051B-

Work in the operating modes targeted functions and targeted fault finding.

2.3.1 Adapt information regarding lining

The mechatronics detects the other control units in the vehicle via the signals in the CAN databus. If the button adapt information regarding lining is pressed, the mechatronics receives a command to forget all systems with which it can communicate.

However, after switching on the ignition all “active systems” with which it can communicate are detected.

No faults can be “generated” with this function. The function adapt information regarding lining is always carried out after the following operations:

- ◆ After installing the mechatronics.
- ◆ After the gearbox has been fitted.
- ◆ After installing the selector lever.
- ◆ After installing another control unit, for example the engine control unit, the ABS control unit or the diagnosis limit for databus (Gateway).
- ◆ After working on the steering column gearshift.

2.3.2 Perform basic setting

The mechatronics memorises important settings in the function COMPLETE BASIC SETTING. The important settings are also memorised, e.g reset to preprogrammed points. For example among others, the synchronisation points and the “vertices” for the engaging lever and the gear switch.

- Only press the button COMPLETE BASIC SETTING:
 - ◆ after interrogating with “targeted fault finding”
 - ◆ after rectifying the fault displayed in the fault memory
 - ◆ or after installing the clutch

2.4 Explanation of the terms used in this workshop manual

These explanations are only related to the automatic gearbox DSG - 0AM. They do not claim to be valid in all cases.

CAN databus

Data transfer. The electrical signals are therefore put into certain forms (Bus). Further information on this can be found in ⇒ Self-study programme No. 24 ; Škoda OCTAVIA; CAN databus; Structure and Function .

DSG

Automatic gearbox DSG. Further information on this can be found in ⇒ Self-study programme No. 75 ; Automatic gearbox DSG - 0AM .

Self-diagnosis

Engine control unit can:

- detect faults
- react to faults
- store faults
- Determine measured values and display them in the measured value block

Protected by copyright. Copying for private or commercial purposes, in part or in whole, is not permitted without the written permission of ŠKODA AUTO A. S. ŠKODA AUTO A. S. does not guarantee or accept any liability with respect to the correctness of information in this document. Copyright by ŠKODA AUTO A. S. ©

Gearbox input r.p.m. sender -G182-

The sender determines the speed at the clutch and sends it to the mechatronics.

Gearbox

The automatic gearbox DSG^o-0AM is also designated as double clutch gearbox. The engine torque is initiated in the gearbox via the two-mass flywheel. The flywheel and the double clutch are interconnected via a serration. The gearbox is built like a 7-speed manual gearbox. Due to the alternative hydraulic activation of the 2 dry clutches, it is operated like an automatic gearbox, i.e. the gears are automatically or manually engaged via the Tiptronic mode. A clutch pedal is not present.

Gear oil

The gearbox has separate oil fillings for mechatronics and manual gearboxes. Oils are designed to be filled for life.

Selector lever lock solenoid -N110-

The selector lever lock solenoid is integrated into the shift mechanism. Prevents the (unintentional) tipping of the selector lever from the positions "P" and "N" for not-operated brake.

Emergency running mode

If individual or several components or sensors fail, the gearbox control unit activates the corresponding backup functions or emergency running programmes. This ensures a nondestructive operation of the gearbox with the respective effect on the function and quality of the shifting.

The emergency running mode is a "status of the control unit", which, if a fault of the control unit is detected, maintains driving safety, protects the gearbox from damage, and ensures that vehicle running will be affected as little as possible.



Parking position

When the vehicle is parked, the selector lever mechanically locks the parking gear thereby preventing the vehicle from moving off (unintentionally).

Shift mechanism

The selector lever position is no longer communicated mechanically, as for the other automatic gearboxes, via the selector lever control cable and the multi-function switch (sensor for driving position) to the gearbox. The selector lever positions or shifting are transmitted via a separate control unit in the shift mechanism via the CAN databus to the mechatronics. The shifting is then performed without control cable. Only in the selector lever position "P" is the parking position engaged mechanically via the selector lever control cable.

Gear-change points change on upward and downward gradients

On upward or downward gradients, gear-changes are selected automatically by additional gear-change mapping, according to accelerator position and driving speed.

- On steep gradients, gear-change mapping is adapted to engine power output.
- On steep gradients, gear-change mapping is adapted to the braking effect of the engine.
- By directly selecting a gear via the Tiptronic, also with a concrete gear, e.g. for a slope during trailer operation, the motor braking effect is also used.

Tiptronic

Another one exists to the right of the normal selector lever gate. In this selector lever gate, the selector lever can be tipped towards the Plus sign (+) to change up the gears manually and vice versa towards the Minus sign (-) to change down the gears manually.

ŠKODA



Protected by copyright. Copying for private or commercial purposes, in part or in whole, is not permitted unless authorised by ŠKODA AUTO A. S. ŠKODA AUTO A. S. does not guarantee or accept any liability with respect to the correctness of information in this document. Copyright by ŠKODA AUTO A. S. ©



30 – Clutch

1 Removing and installing the double clutch

Short description

Detach the clutch “upwards” when the gearbox is removed. The mechatronics remains on the gearbox.

If a new clutch is installed, the positions of the engaging bearings for “K 1” and “K 2” must be determined and adjusted. Then the clutch is pressed onto the drive shaft.

When installing a clutch, “most” of the mechanics press the clutch onto the drive shaft up to the stop. This is not the optimum position of the clutch!

After the installation, the clutch is therefore slightly pulled “upwards” against the circlip.

Overview:

Transporting the gearbox and secure to the assembly support uses, in part or in whole, is not permitted unless authorised by ŠKODA AUTO A. S. ŠKODA AUTO A. S. does not guarantee or accept any liability with respect to the correctness of information in this document. Copyright by ŠKODA AUTO A. S. ©
 ⇒ [page 104](#) .

Remove double clutch ⇒ [page 11](#) .

Adjust the positions of the engaging bearing for clutch “K 1 and K 2” - “old design” (the large adjusting washer for the clutch “K1” is installed on the large bearing, the small adjusting washer for the clutch “K2” is installed on the small bearing) ⇒ [page 15](#) .

Adjust the positions of the engaging bearing for clutch “K 1 and K 2” - “new design” (the large adjusting washer for the clutch “K1” is installed on the large bearing, the small adjusting washer for the clutch “K2” is installed under the small bearing)
 ⇒ [page 21](#) .



Note

In case of replacement of the clutch, only the “new design” is supplied as a spare part, (can also be used for gearboxes with the “old design”) ⇒ Electronic Catalogue of Original Parts .

Install double clutch - “old design” ⇒ [page 31](#) .

Install double clutch - “new design” ⇒ [page 37](#) .



Note

The clutch is self-adjusting. Vibrations can have a negative effect on the adjusting device. Therefore do not let the clutch fall. Do not let the clutch fall into the gearbox when installing it. Also when the mechatronics is removed, the “removal” of the drifts below the engaging levers can have a negative effect on the adjusting device.

1.1 Remove double clutch

Special tools and workshop equipment required

- ◆ Assembly stand -MP9-101-
- ◆ Hook -3438-

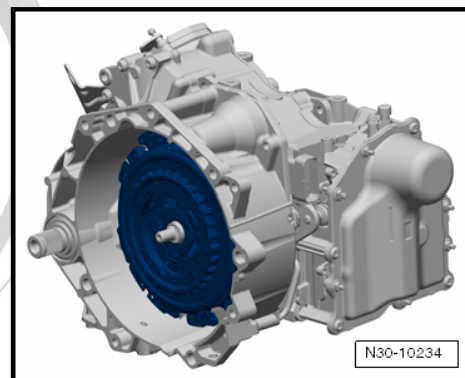



- ◆ Supporting bridge -T10323-
- ◆ Thrust piece -T10368-
- ◆ Extractor -T10373-
- ◆ Thrust piece -T10376-
- ◆ Gearbox mount -T30108-
- ◆ Gearbox mount -T30109 (VW 353)-
- Gearbox removed
- The mechatronics for double clutch gearbox -J743 - is installed on the gearbox
- Remove both ventilation caps -arrows- and close with suitable screw plugs so that no oil can flow out.

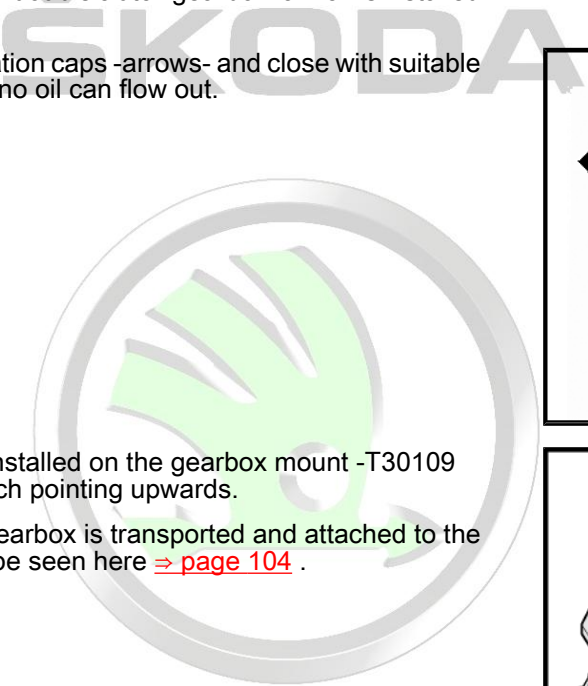

The gearbox must be installed on the gearbox mount -T30109 (VW 353)- with the clutch pointing upwards.

The way in which the gearbox is transported and attached to the assembly support can be seen here [⇒ page 104](#) .

Protected by copyright. Copying for private or commercial purposes, in part or in whole, without the written permission of ŠKODA AUTO A. S. ŠKODA AUTO A. S. does not guarantee the accuracy of the information in this document. Copyright by ŠKODA AUTO A. S.

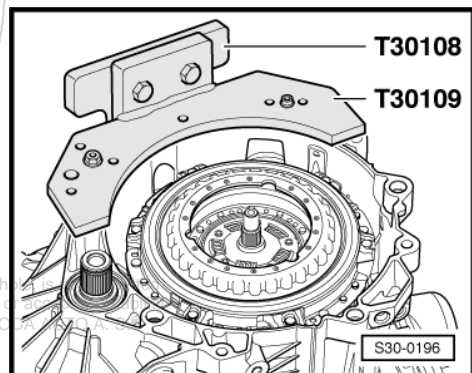
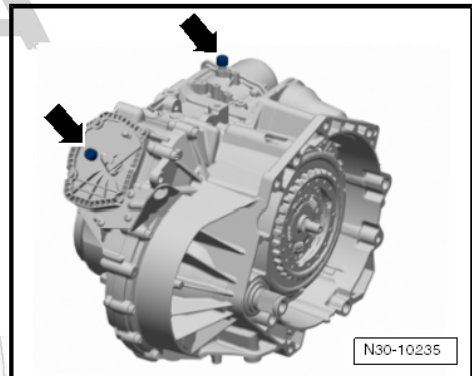

- Remove the circlip for the hub -arrow-.

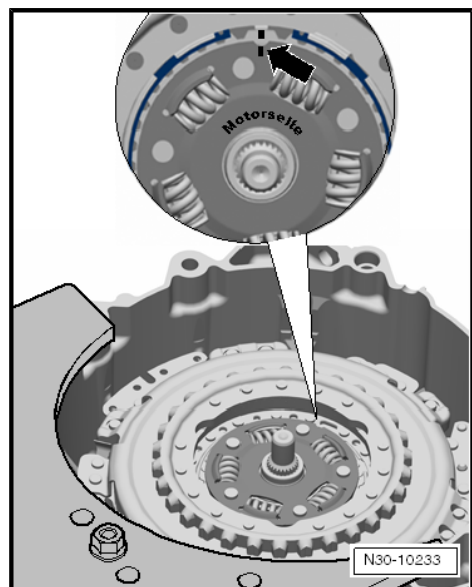



- Take out the hub with hook -3438- -A- and screwdriver -B-.

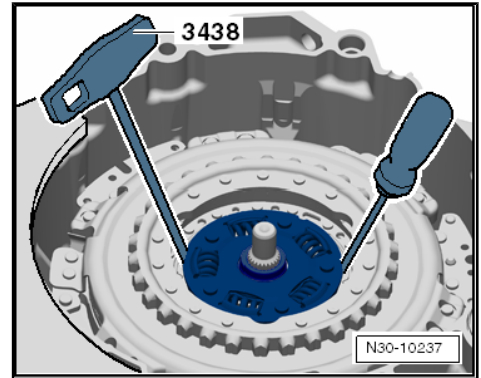

- Remove the circlip for the clutch -arrow-.

i Note

- ◆ *It is possible that the clutch is resting at the circlip so close that the circlip "fits very tightly". In this case it is possible to press the clutch slightly downwards as described in the following work procedure. In doing so, the circlip is released. Do not knock on the clutch or the shaft with a hammer!*
- ◆ *Always replace circlip -arrow- → Electronic Catalogue of Original Parts .*

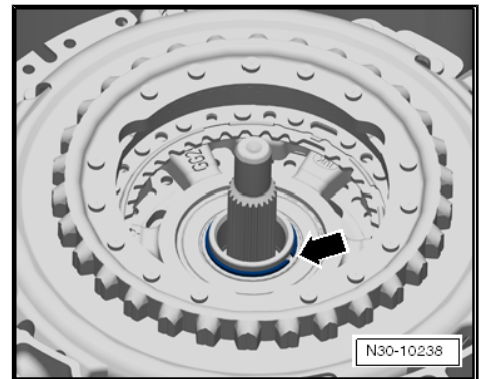

The circlip -arrow- for the clutch cannot be removed:

i Note

In the following description the clutch is pressed slightly downwards in the event that the circlip cannot be removed.

- Position the supporting bridge -T10323- parallel to the flange of the clutch housing.
- Equalise distances, e.g using washers -B- with a total thickness of 15 mm.
- Attach the supporting bridge -T10323- with screws -A-.

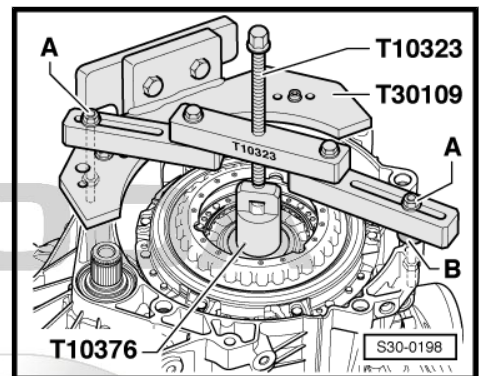

i Note

Fasten screws -A- with nuts.

- Carefully press the clutch downwards via the spindle.
- Remove supporting bridge -T10323- .

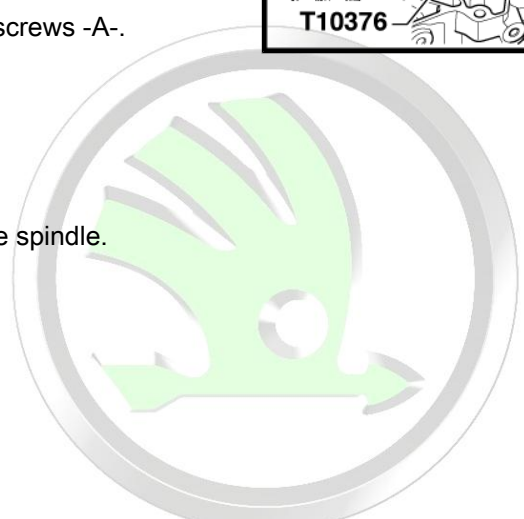



- Remove the circlip for the clutch -arrow-.

The circlip for the clutch -arrow- is removed:

ŠKODA



- Insert the extractor -T10373- in the clutch and remove the clutch.

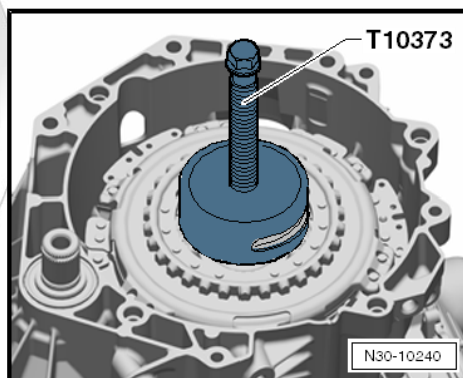
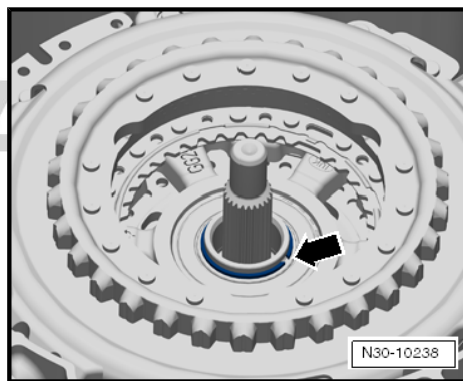

- Remove the clutch together with the extractor -T10373-

Protected by copyright. Copying for private or commercial purposes, in part or in whole, is not permitted without the prior written permission of ŠKODA AUTO A.S. ŠKODA does not guarantee the correctness of information in this document. Copyright by ŠKODA

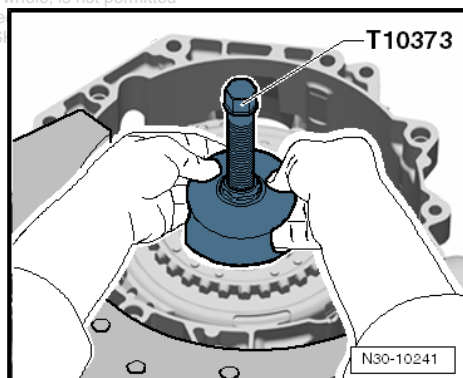

- Remove the small engaging bearing.
- Remove the large engaging lever.

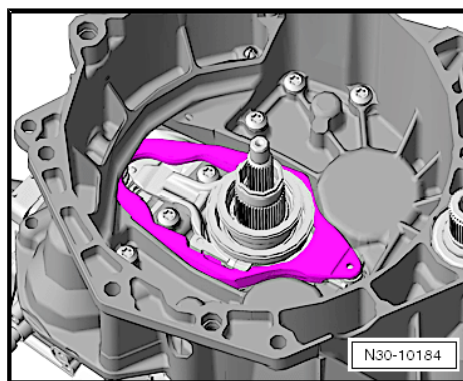

- Remove the screws and the small engaging lever.

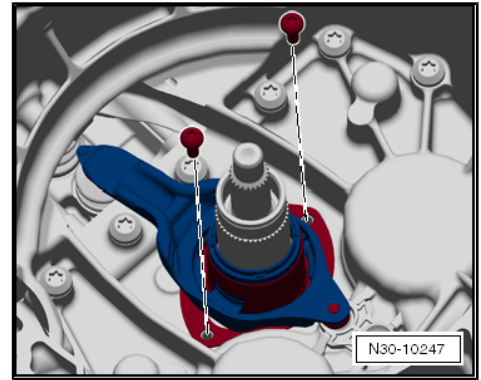

- Remove the support for the engaging lever.

Before installing the clutch, check if it must be adjusted or not - "old design" ⇒ [page 15](#) .

Before installing the clutch, check if it must be adjusted or not - "new design" ⇒ [page 21](#) .

Install double clutch - "old design" ⇒ [page 31](#) .

Install double clutch - "new design" ⇒ [page 37](#) .

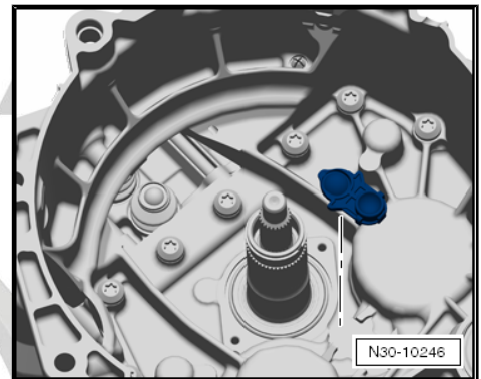

1.2 Adjust the positions of the engaging bearing for clutch "K 1 and K 2" - "old design"

Special tools and workshop equipment required

- ◆ Gauge block -T10374 -
- ◆ Straightedge -T40100-
- ◆ Adhesive -AMV 195 KD1 01-
- ◆ Depth gauge

Protected by copyright. Copying for private or commercial purposes, in part or in whole, is not permitted unless authorised by ŠKODA AUTO A. S. ŠKODA AUTO A. S. does not guarantee or accept any liability with respect to the correctness of information in this document. Copyright by ŠKODA AUTO A. S. ©

Note

The adjusting washer for the clutch "K1" is installed on the large bearing, the adjusting washer for the clutch "K2" is installed on the small bearing.

Position of the engaging bearing must be performed if:

- ◆ The engaging levers were replaced.
- ◆ The engaging bearings were replaced.
- ◆ The support of the engaging levers was replaced.
- In order to ensure a correct position of the straightedge - T40100- , no "irregularities" must be present on the gearbox flange.
- Remove previous adjusting washers from the engaging bearings.
- Clean the seating surfaces at the engaging bearings.
- Install both engaging levers and engaging bearings.



- Select washers of 1.4 mm thickness from the supplied washers.

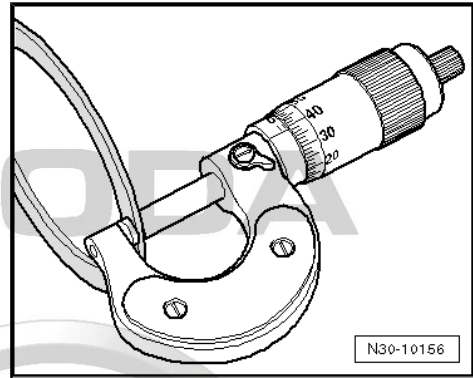

- Place an adjusting washer of 1.4 mm thickness on each bearing -arrows-.

i Note

- ◆ For measuring, adjusting washers of 1.4 mm thickness must be used in order to determine the correct adjusting washers.
- ◆ As there are 2 clutches, 2 steps are performed for the adjustment. Different measurements are carried out according to these steps.
- ◆ Therefore the following work sequence must be observed.

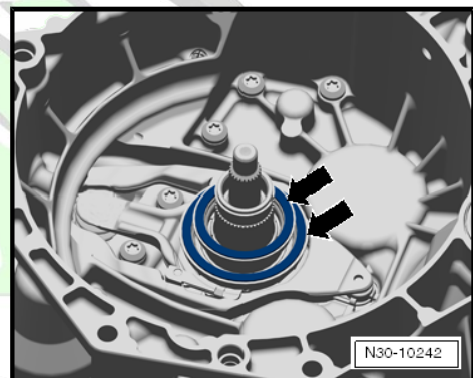

Start with the "large" engaging bearing for the clutch 1 "K 1"
⇒ [page 16](#) .

Protected by copyright. Copying for private or commercial purposes, in part or in whole, is not permitted unless authorised by ŠKODA AUTO A. S. ŠKODA AUTO A. S. does not guarantee or accept any liability with respect to the correctness of information in this document. Copyright by ŠKODA AUTO A. S. ©

1.2.1 Determine the adjusting washer for the "large" engaging bearing "K 1" of the clutch 1

- Remove again the small engaging bearing -arrow- together with the adjusting washer of 1.4 mm thickness and place it down.

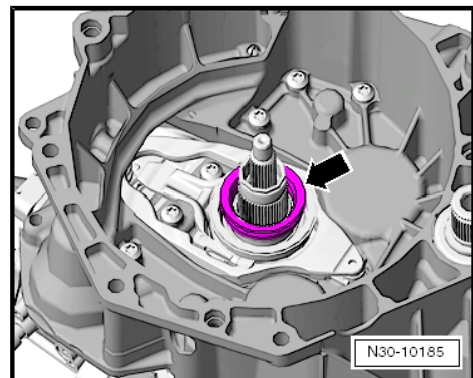

- Position the gauge block -T10374- on the "large" engaging bearing.
- Press the gauge block -T10374- onto the engaging bearing and simultaneously turn.

i Note

If the engaging bearing turns with the washer, the gauge block -T10374- is also "fitted" correctly on the engaging bearing.

First measurement for "K 1"

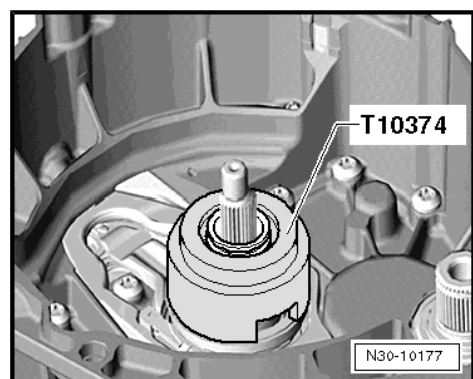

- Position the straightedge -T40100- onto the gearbox flange and measure the distance from the input shaft using the depth gauge.
- Note the value and mark with "b".

Example: "b" = 62.3 mm

Second measurement for "K 1"

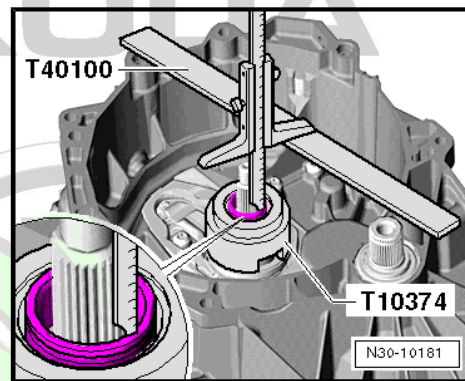

- Measure the distance from the straightedge -T40100- to the gauge block -T10374- using the depth gauge.

Note

- ◆ The measurement is carried out twice using the depth gauge for a precise measurement. Preferably measure at opposite-facing points.
- ◆ In this way a more precise result can be achieved because the inaccuracy, due to "wobbling" at the engaging bearing, is minimized.

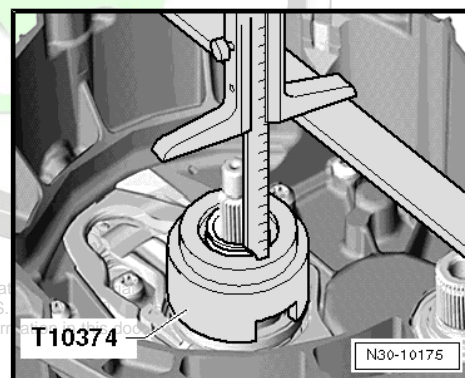

- Repeat the measurement at the opposite-facing point of the gauge block -T10374- .
- Calculate the mean value of both measurements, note and mark with "a".

Example: "a" = 64.0 mm

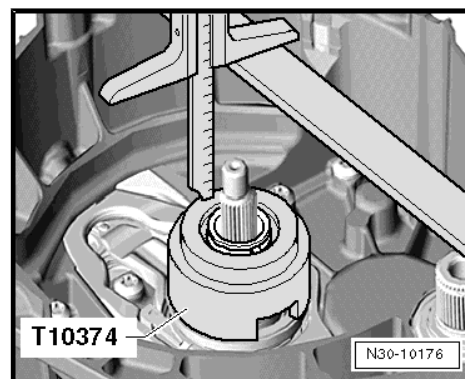

Determine adjusting washer for engaging bearing of clutch "K 1"

- Deduct the first value "b" from the second value "a".

In the example, the calculation is as follows:

"a" - "b" = 64.0 mm - 62.3 mm = 1.7 mm

- Select the suitable adjusting washer according to the table.

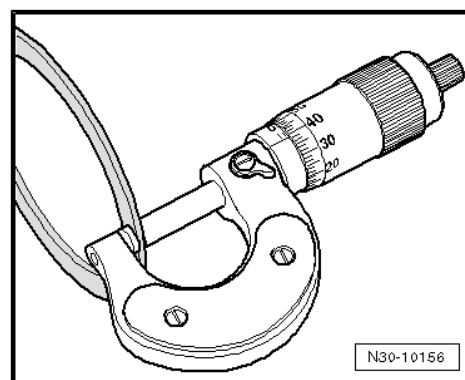

Value for engaging bearing of clutch "K 1"		The thickness of the washer to be used, in mm
from	to	
0,71	0,9	0,8
0,91	1,1	1,0
1,11	1,3	1,2
1,31	1,5	1,4
1,51	1,7	1,6



Value for engaging bearing of clutch "K 1"		The thickness of the washer to be used, in mm
1,71	1,9	1,8
1,91	2,1	2,0
2,11	2,3	2,2
2,31	2,5	2,4
2,51	2,7	2,6
2,71	2,9	2,8

In the example, an adjusting washer of 1,6 mm thickness must be used.

- If necessary, replace the washer of 1.4 mm -thickness-, which has been used for the measurement, with the washer of the required thickness determined just now.

 **Caution**

Risk of damage to the clutch as well as to other components!

◆ *For the adjustment, only one adjusting washer must be placed on all engaging bearings.*

Thus the position of the engaging bearing for the clutch "K 1" is adjusted.

Now the same work steps must be carried out for the engaging bearing of clutch "K 2" ⇒ [page 18](#) .

1.2.2 Determine the adjusting washer for the "small" engaging bearing "K 2" of the clutch 2

- For the following measurement, the "large" engaging lever must be removed together with the engaging bearing of clutch "K 1".

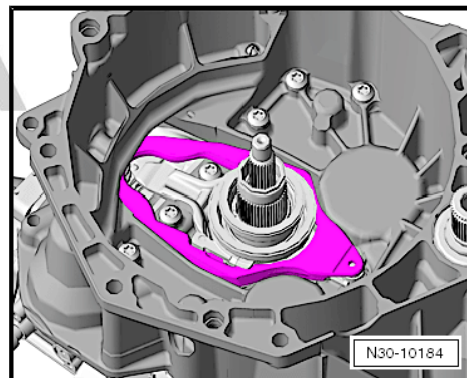

- Only insert the small release bearing with an -adjusting washer of 1.4 mm thickness-.

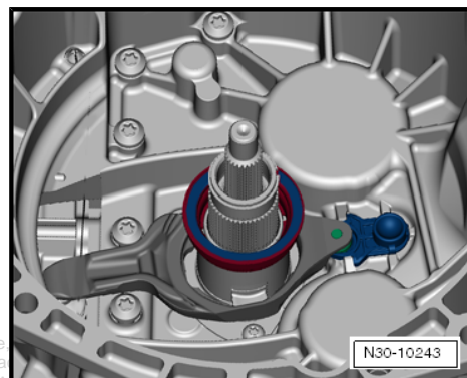

Protected by copyright. Copying for private or commercial purposes, in part or in whole unless authorised by ŠKODA AUTO A. S. ŠKODA AUTO A. S. does not guarantee or accept any liability with respect to the correctness of information in this document. Copyright by ŠKODA AUTO A. S.

The small engaging bearing fits in only one position due to the 4 grooves.

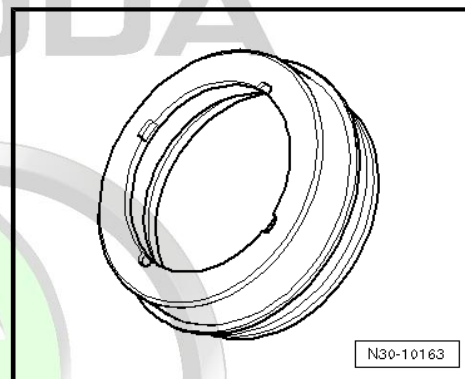

- Insert the engaging bearing and check the correct fit by "turning".

i Note

The 4 grooves must catch into the support.

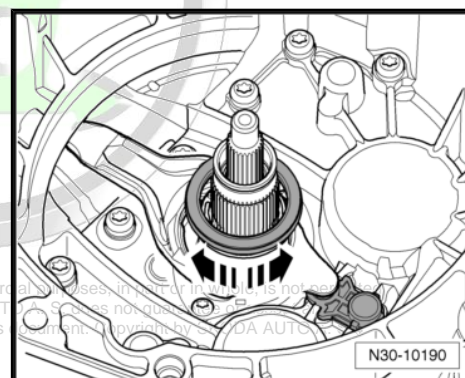

Protected by copyright. Copying for private or commercial purposes, in part or in full, is not permitted unless authorised by ŠKODA AUTO A. S. ŠKODA AUTO assumes no liability for errors or omissions with respect to the correctness of information in this document. Copyright by ŠKODA AUTO

- Position the gauge block -T10374- on the small engaging bearing.

First measurement for "K 2"

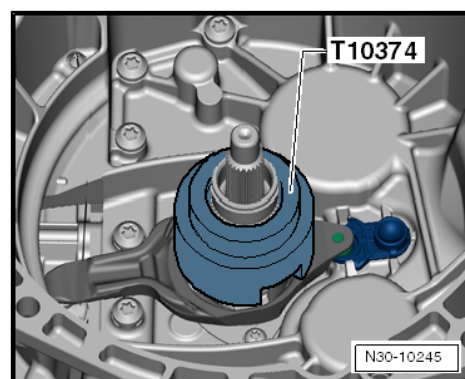

- Position the straightedge -T40100- onto the gearbox flange and measure the distance from the input shaft using the depth gauge.

- Note the value and mark with "b".

Example: "b" = 62.3 mm

Second measurement for "K 2"

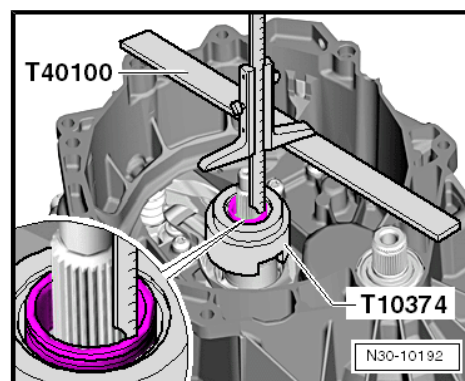



- Measure the distance from the straightedge -T40100- to the gauge block -T10374- using the depth gauge.

i Note

- ◆ *The measurement is carried out twice using the depth gauge for a precise measurement. Preferably measure at opposite-facing points.*
- ◆ *In this way a more precise result can be achieved because the inaccuracy, due to "wobbling" at the engaging bearing, is minimized.*

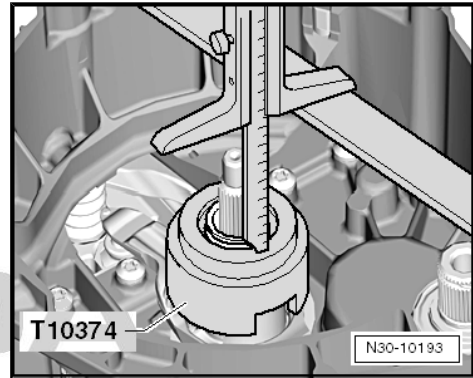

- Repeat the measurement at the opposite-facing point of the gauge block -T10374- .
- Calculate the mean value of both measurements, note and mark with "a".

Example: "a" = 63.5 mm

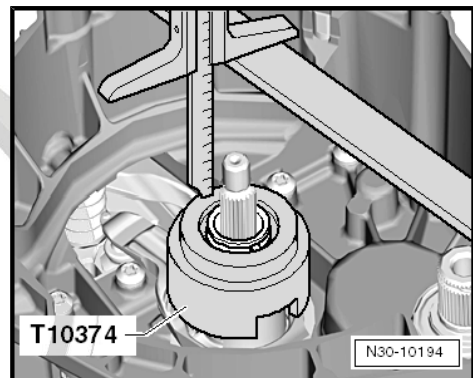

Determine adjusting washer for engaging bearing of clutch "K 2"

- Deduct the first value "b" from the second value "a".

In the example, the calculation is as follows:

"a" - "b" = 63.5 mm - 62.3 mm = 1.2 mm

- Select the suitable adjusting washer according to the table.

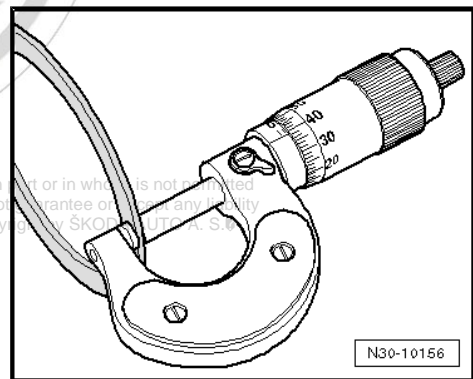

Value for engaging bearing of clutch "K 2"		The thickness of the washer to be used, in mm
from	to	
0,71	0,9	0,8
0,91	1,1	1,0
1,11	1,3	1,2
1,31	1,5	1,4
1,51	1,7	1,6
1,71	1,9	1,8
1,91	2,1	2,0
2,11	2,3	2,2
2,31	2,5	2,4
2,51	2,7	2,6
2,71	2,9	2,8

In the example, an adjusting washer of 1.2 mm thickness must be used.

- If necessary, replace the washer of 1.4 mm -thickness-, which has been used for the measurement, with the washer of the required thickness determined just now.



Caution

Risk of damage to the clutch as well as to other components!

- ◆ ***For the adjustment, only one adjusting washer must be placed on all engaging bearings.***

Thus the position of the engaging bearing for the clutch "K 2" is also adjusted.

- Stick both adjusting washers with adhesive -AMV 195 KD1 01- on their point.
- The clutch can be installed ⇒ [page 31](#) .

1.3 Adjust the positions of the engaging bearing for clutch "K 1 and K 2" - "new design"

Special tools and workshop equipment required

- ◆ Gauge block -T10374 -
- ◆ Straightedge -T40100-
- ◆ Adhesive -AMV 195 KD1 01-
- ◆ Digital depth gauge



Note

The adjusting washer for the clutch "K1" is installed on the large bearing, the adjusting washer for the clutch "K2" is installed under the small bearing.

Protected by copyright. Copying for private or commercial purposes, in part or in whole, is not permitted unless authorised by ŠKODA AUTO A. S. ŠKODA AUTO A. S. does not guarantee or accept any liability with respect to the correctness of information in this document. Copyright by ŠKODA AUTO A. S. ©

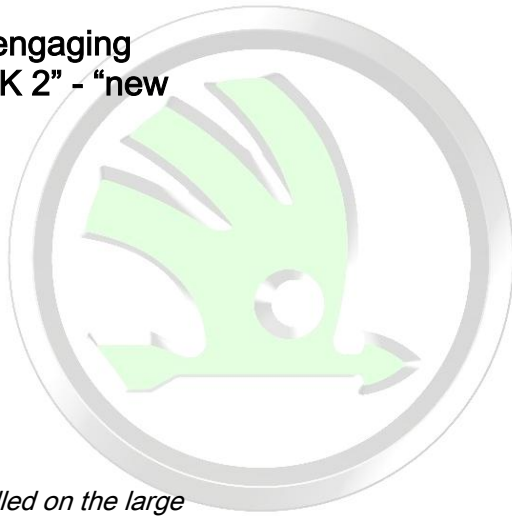



The position of the engaging bearing must be adjusted after the clutch and its controls were replaced.

- ◆ The support is also part of the control.

If all the mentioned parts are only removed and reinstalled, there is nothing to adjust.

Conditions:

- Only use proper tools.
- The flange of the clutch housing must be free of "irregularities". This ensures a good position of the straightedge.
- The mechatronics is installed.

Short description

The position of the engaging bearing is comparable with the clutch play of a mechanical manual gearbox. In the automatic gearbox DSG - 0AM, tolerances are present in the engaging system of the gearbox and in the gearbox itself. The tolerances also exist inside the double clutch. These tolerances must be considered separately when adjusting.

In the following procedure is first shown how to establish all the necessary dimensions on the "gearbox side" in order to determine the suitable adjusting washer. The tolerances on the gearbox side and the tolerances in the clutch determine the thickness of the adjusting washer.

First a dimension "B" must be established. This dimension is required for both clutches "K 1" and "K 2".

In addition, a dimension "A" is established for each clutch. The following figures N30-10291 and N30-10292 show where to measure these dimensions.

"K 1"

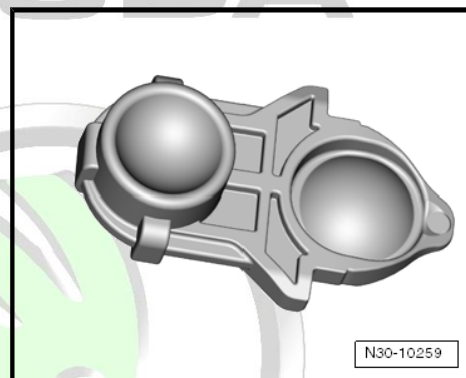

This document is not for private or commercial purposes, in part or in whole, is not permitted unless authorised by ŠKODA AUTO A. S. ŠKODA AUTO A. S. does not guarantee or accept any liability with respect to the correctness of information in this document. Copyright by ŠKODA AUTO A. S.

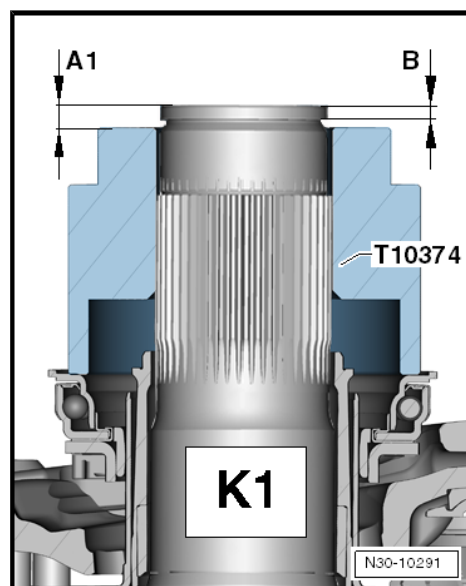

“K 2”

Note

Perform the following work steps accurately and “in sequence”.

Adjusting:

- Install the parts of the clutch up to the large engaging lever
=> [page 37](#) .

Do not insert an adjusting washer.

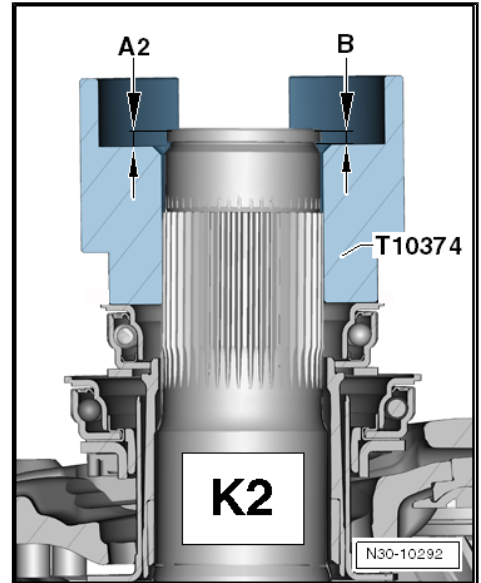

- Install the circlip of the outer drive shaft -arrow-.

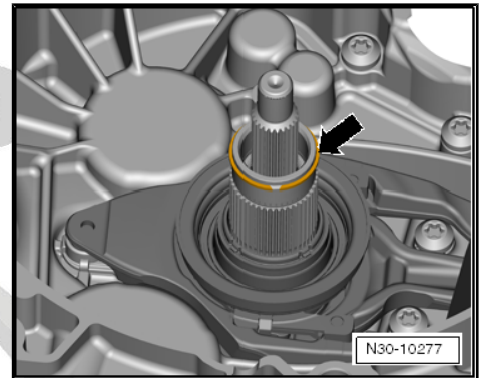
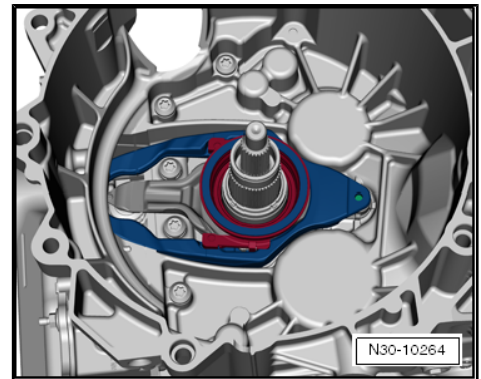

- Place the ruler -T40100- upright on the flange of the clutch housing.

Note

The ruler -T40100- must remain in this position during the following measurements. Do not turn or remove it.

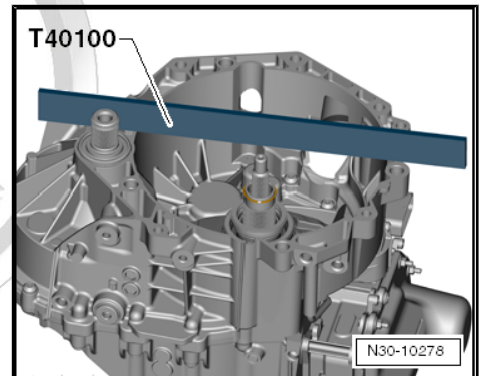

Protected by copyright. Copying for private or commercial purposes, in whole or in part, is prohibited unless authorised by ŠKODA AUTO A. S. ŠKODA AUTO A. S. does not guarantee or accept any liability with respect to the correctness of information in this document. Copyright by ŠKODA AUTO A. S. ©



- Place the digital depth gauge -A- on the outer drive shaft -B-.
- Reset the depth gauge to "zero".

ŠKODA

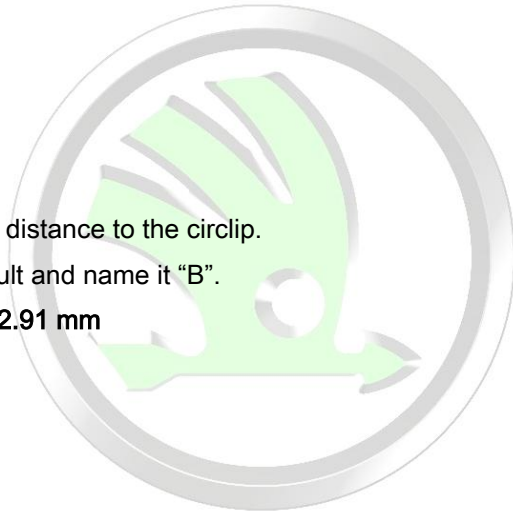

- Measure the distance to the circlip.
- Note the result and name it "B".

Example: "B" = 2.91 mm

Protected by copyright. Copying for private or commercial purposes, in part or in whole, is not permitted unless authorised by ŠKODA AUTO A. S. ŠKODA AUTO A. S. does not guarantee or accept any liability with respect to the correctness of information in this document. Copyright by ŠKODA AUTO A. S.

- Measure the dimension "B" once more at the opposite-facing point.



Note

Do not measure on the joint of the ring. The ring could be pressed off from the joint and thus the measuring result will be inaccurate.

- Remove the circlip again.

This ring must not be reinstalled!

- Determine the mean value from both measurement results.

Example:

$$\text{Dimension "B"} = B1+B22 = 2,91+3,02 = 2.96$$

This dimension "B" is required for the following calculations.

In the following example calculations "B" should be = 2.96 mm. The dimension "B" is for this example, there can be another value "B" for different gearboxes.

As there are 2 clutches, 2 steps are performed for the adjustment.

Each measurement requires different preparatory measures, including a few calculations. Please observe the following work procedures.

First determine the adjusting washer for the clutch "K 1".

Do not insert an adjusting washer!

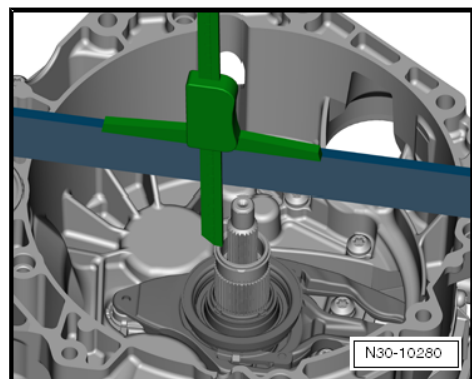
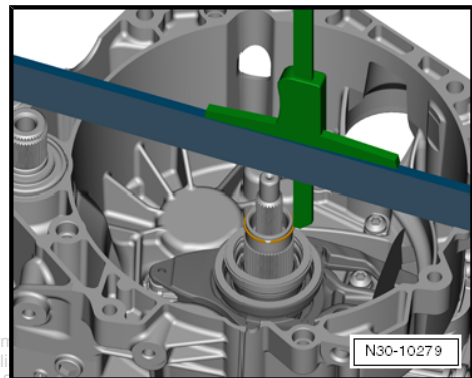
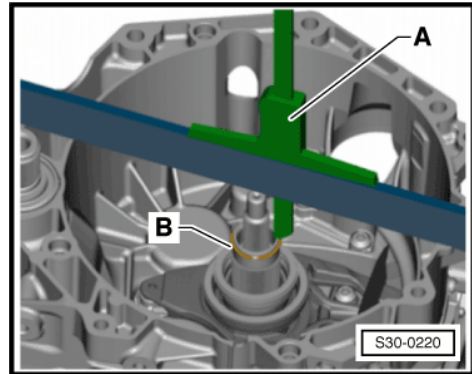



- Position the gauge block -T10374- on the "large" engaging bearing.
- Press on the gauge block -T10374- once and turn it at the same time.

In this way one can observe how the engaging bearing turns. Thus, the "gauge block" is also positioned -T10374- correctly on the bearing.

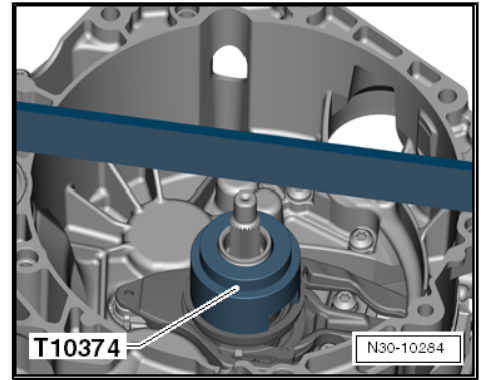

- Place the digital depth gauge at the "top" on the outer drive shaft.

The ruler -T40100- is already positioned "upright" on the flange of the clutch housing => [page 23](#) .

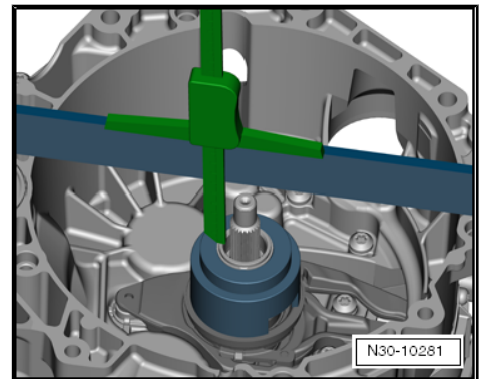

- Measure the distance from the "shaft end" to the gauge block -T10374- .

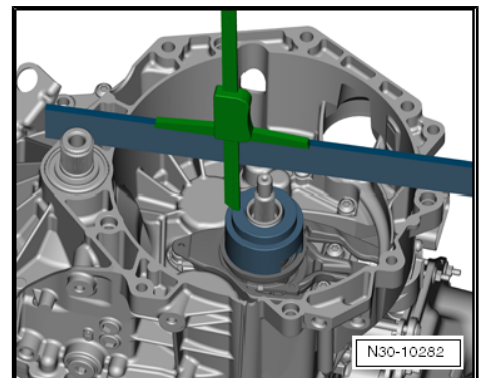

ŠKODA



Protected by copyright. Copying for private or commercial purposes, in part or in whole, is not permitted unless authorised by ŠKODA AUTO A. S. ŠKODA AUTO A. S. does not guarantee or accept any liability with respect to the correctness of information in this document. Copyright by ŠKODA AUTO A. S. ©



- Position the digital depth gauge twice at opposite-facing points for a precise measurement.

In this way, an even more precise value is determined as the inaccuracy resulting from the “wobbling” on the engaging bearing is thus minimised.

- Note the mean value of both measurements to the gauge block -T10374 - .
- Note this value and name it “A1”.

Example:

Dimension “A1” = $2,61 + 2,812 = 2.71$

Example: “A1” = 2.71 mm

The following calculation:

“A1” minus “B” plus height of the gauge block -T10374- = depth of the engaging bearing of clutch 1.

The height of the gauge block -T10374- is always the same. It is: 51.81 mm.

Example calculation:

$2.71 \text{ mm} \text{ minus } 2.96 \text{ mm} \text{ plus } 51.81 \text{ mm} = 51.56 \text{ mm}.$

You have now determined the value of how deep the engaging bearing is actually positioned in the gearbox.

The depth of the bearing must be 50.08 mm on each gearbox.

The nominal dimension “50.08 mm” is deducted from the actual dimension. Thus, the actual air passage of clutch 1 is determined.

- Continue the calculation:

The determined value (in the example: 51.56 mm) minus the nominal value = the air passage of the clutch.

Example calculation:

$51.56 \text{ mm} \text{ minus } “50.08 \text{ mm}” = \text{air passage of clutch 1} = 1.48 \text{ mm}.$

Now the tolerances in the double clutch must be included in this calculation. This is a very simple procedure:

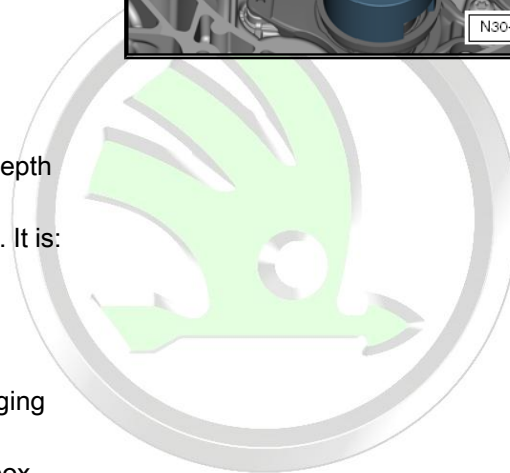
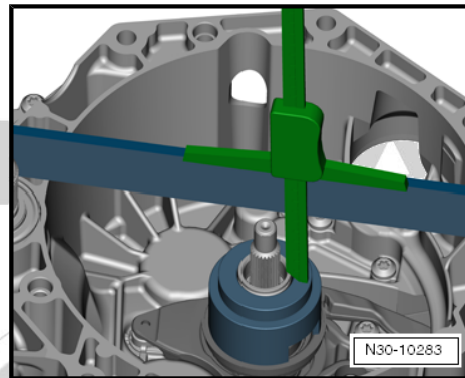

- Please read off the value of the clutch tolerance -arrow- from the "new" clutch.

A value between minus 0.40 and plus 0.40 mm is attributed to the new clutch.

- Note this value.

Example 1: "-0.40 mm" is given on your clutch.

The last calculation for "K 1": "Its determined" air passage minus the value of clutch 1 =

1.48 mm minus 0.40 = 1.08 mm.

Example 2: "+0.20 mm" is given on your clutch.

Then the last calculation for "K 1" is done as follows: 1.48 mm plus 0.20 = 1.68 mm.

- Select the correct washer from the table and install it.

Determined thickness of the washer		Washer to be installed in mm
from	to	
0,31	0,90	0,8
0,91	1,10	1,0
1,11	1,30	1,2
1,31	1,50	1,4
1,51	1,70	1,6
1,71	1,90	1,8
1,91	2,10	2,0
2,11	2,30	2,2
2,31	2,50	2,4
2,51	2,70	2,6
2,71	3,30	2,8

- From the delivered washers, determine the adjusting washer which is required.



WARNING

At a later stage, just insert this 1 adjusting washer. Do not insert 2 washers.

Thus, the "correct" adjusting washer for "K 1" is determined. Please install this adjusting washer when installing the clutch at a later stage.

- Proceed with the adjustment for the clutch "K 2".

Determine the adjusting washer for the "K 2".

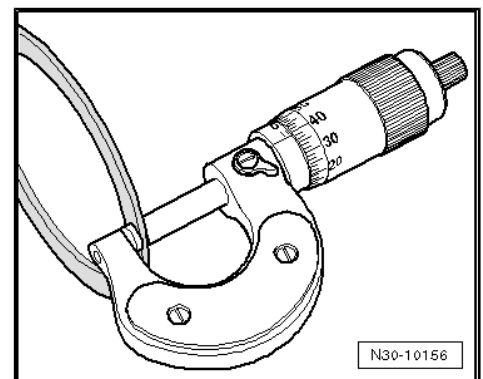
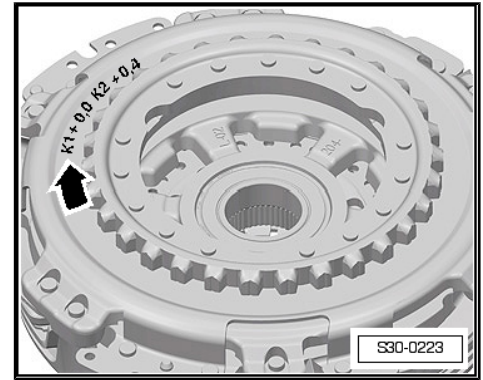



- Only insert the small bearing.

Do not insert an adjusting washer!

ŠKODA

The small engaging bearing fits in only one position due to the 4 grooves.

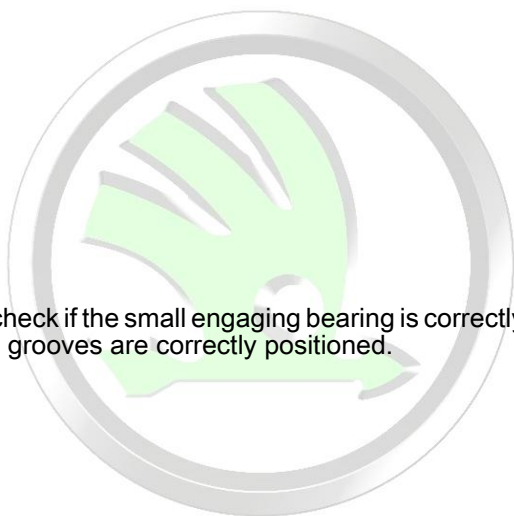

- While “turning”, check if the small engaging bearing is correctly installed and the grooves are correctly positioned.

Protected by copyright. Copying for private or commercial purposes, in part or in whole, is not permitted unless authorised by ŠKODA AUTO A. S. ŠKODA AUTO A. S. does not guarantee or accept any liability with respect to the correctness of information in this document. Copyright by ŠKODA AUTO A. S.

- Position the gauge block -T10374- “with the large opening upwards” on the small bearing.

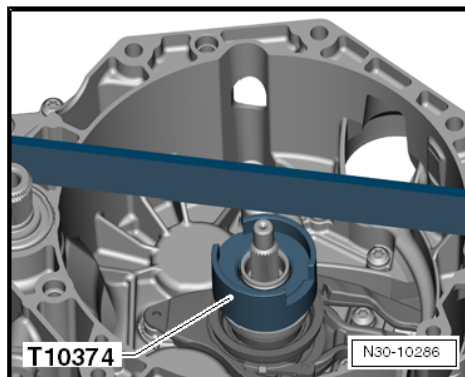
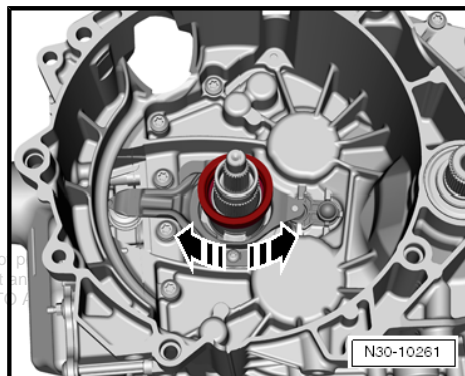
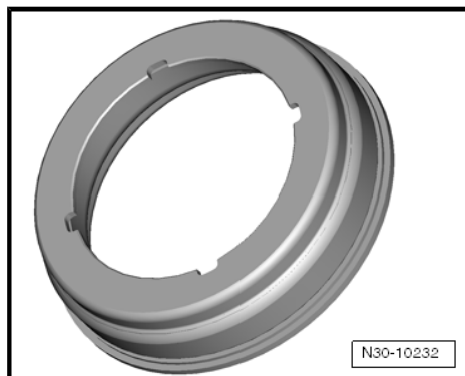
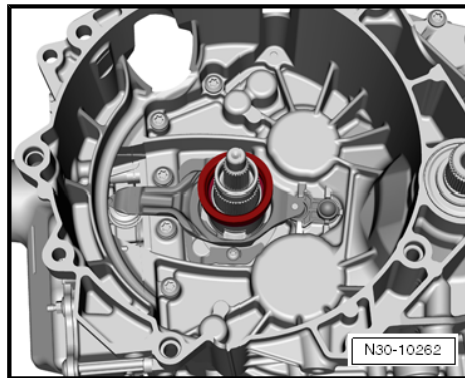



- Place the digital depth gauge at the "top" on the outer drive shaft.
- Reset the depth gauge to "zero".

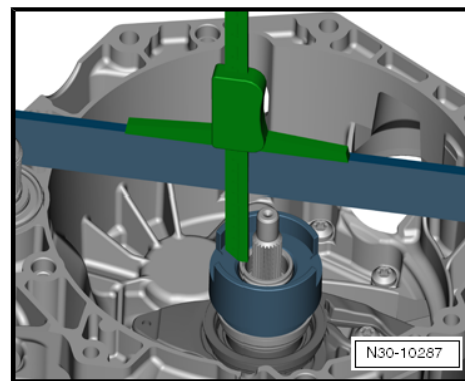

- Measure the distance from the "shaft end" to the gauge block -T10374- .

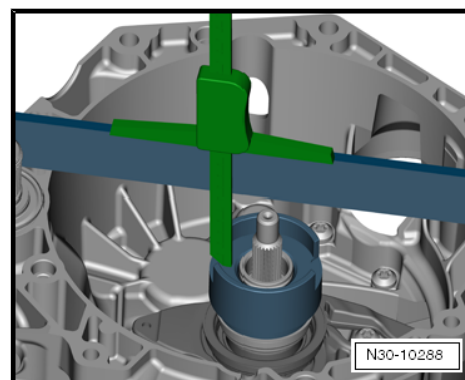

ŠKODA



Protected by copyright. Copying for private or commercial purposes, in part or in whole, is not permitted unless authorised by ŠKODA AUTO A. S. ŠKODA AUTO A. S. does not guarantee or accept any liability with respect to the correctness of information in this document. Copyright by ŠKODA AUTO A. S. ©



- Position the digital depth gauge twice at opposite-facing points for a precise measurement.

In this way, an even more precise value is determined as the inaccuracy resulting from the “wobbling” on the engaging bearing is thus minimised.

- Note the mean value of both measurements to the gauge block -T10374 - .
- Note this value and name it “A2”.

Example:

Dimension “A2” = 2,50+2,542 = 2.52

Example: “A2” = 2.52 mm

The following calculation:

“A2” minus “B” plus height of the gauge block -T10374- = depth of the engaging bearing of clutch 2.

The height of the gauge block -T10374- is always the same. On the inside, it is: 36.20 mm.

Example calculation:

2.52 mm minus 2.96 mm plus 36.20 mm = 35.76 mm.

You have now determined the value of how deep the engaging bearing is actually positioned in the gearbox.

The depth of the bearing must be 34.35 mm on each gearbox.

The nominal dimension “34.35 mm” is deducted from the actual dimension. Thus, the actual air passage of clutch 2 is determined.

- Continue the calculation:

The determined value (in the example: 35.76 mm) minus the nominal value = the air passage of the clutch.

Example calculation:

35.76 mm minus “34.35 mm” = air passage of clutch 2 = 1.41 mm.

Now the tolerances in the double clutch must be included in this calculation. This is a very simple procedure:

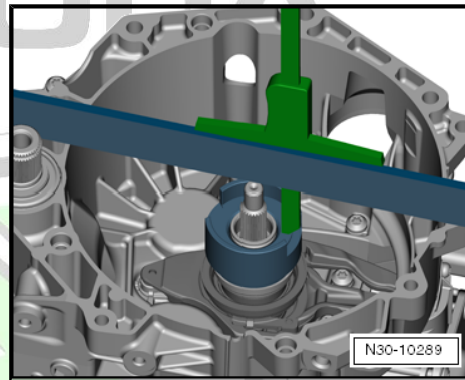

- Please read off the value of the clutch tolerance -arrow- from the "new" clutch.

A value between minus 0.40 and plus 0.40 mm is attributed to the new clutch.

- Note this value.

Example 1: "-0.40 mm" is given on your clutch.

The last calculation for "K 2": "Its determined" air passage minus the value of clutch 2 =

$$1.41 \text{ mm} \text{ minus } 0.40 = 1.01 \text{ mm.}$$

Example 2: "+0.20 mm" is given on your clutch.

Then the last calculation for "K 2" is done as follows: 1.41 mm plus 0.20 = 1.61 mm.

- Select the correct washer from the table.

Determined thickness of the washer		Washer to be installed in mm
from	to	
0,31	0,90	0,8
0,91	1,10	1,0
1,11	1,30	1,2
1,31	1,50	1,4
1,51	1,70	1,6
1,71	1,90	1,8
1,91	2,10	2,0
2,11	2,30	2,2
2,31	2,50	2,4
2,51	2,70	2,6
2,71	3,30	2,8

Protected by copyright. Copying for private or commercial purposes, in part or in whole, is not permitted unless authorised by ŠKODA AUTO A. S. ŠKODA AUTO A. S. does not guarantee or accept any liability for errors or omissions. Copyright by ŠKODA AUTO A. S. ©

- From the delivered washers, determine the adjusting washer which is required.

⚠ WARNING

At a later stage, just insert this 1 adjusting washer. Do not insert 2 washers.

Thus, the "correct" adjusting washer for "K 2" is also determined. Please install this adjusting washer when installing the clutch at a later stage. This washer belongs under the small engaging bearing.

- The clutch can be installed ⇒ [page 37](#) .

1.4 Install double clutch - "old design"

Special tools and workshop equipment required

- ◆ Extractor -T10373-
- ◆ Supporting bridge -T10323-
- ◆ Thrust piece -T10368-
- ◆ Thrust piece -T10376-

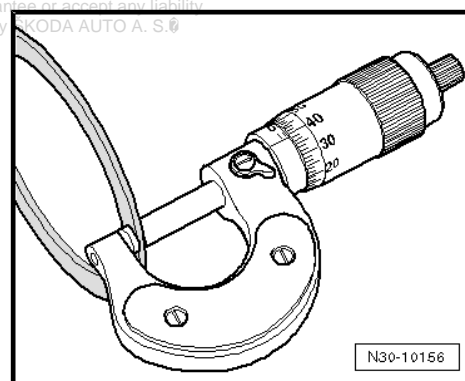
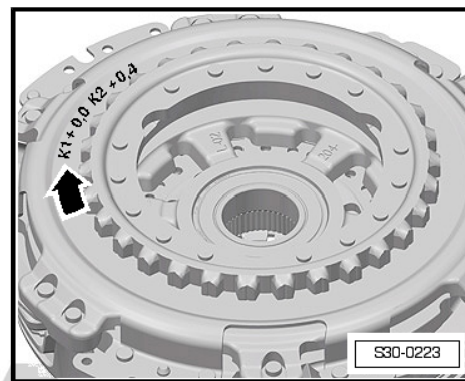



◆ Adhesive -AMV 195 KD1 01-



Caution

Risk of damage to the clutch as well as to other components!

- **There must not be any oil or grease present on the components for the clutch which should be installed!**
- **The positions of the engaging bearing must be correctly set.**

The adjustment can only be performed before installing the clutch.

After carrying out certain tasks, the position of the engaging bearing must be adjusted ⇒ [page 15](#).

Only if the positions of the engaging bearing are correct, the installation can be continued!



Note

The adjusting washer for the clutch "K1" is installed on the large bearing, the adjusting washer for the clutch "K2" is installed on the small bearing.

- Insert the plastic support of the engaging levers and check for correct fit.

Protected by copyright. Copying for private or commercial purposes, in part or in whole, is not permitted without the express written consent of ŠKODA. ŠKODA does not guarantee the correctness of information in this document. Copyright by ŠKODA.

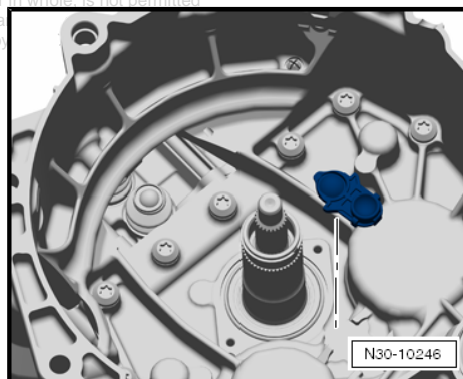

If the "small" engaging lever is removed:

- Install the "small" engaging lever with guide bushing.
- Check the correct fit of the engaging lever.
- Screw down the engaging lever with 2 new screws.

Tightening torque: 8 Nm + 90°

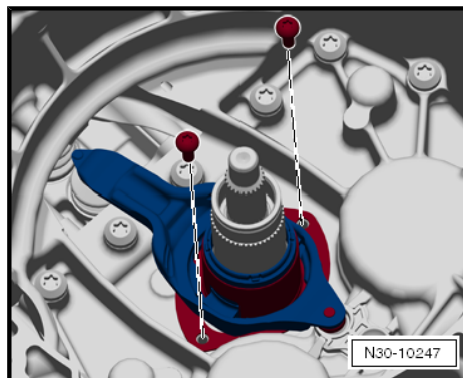

The support of the engaging lever and the engaging bearing actuation must be free of oil and grease, clean if necessary.

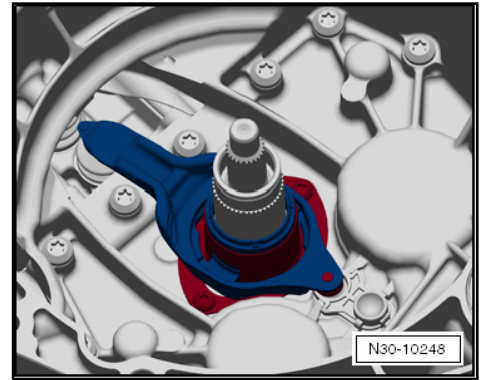

- If it is not yet inserted, then insert the other "larger" engaging lever.
- Check the correct position of both engaging levers.
- Insert the large engaging bearing and check the correct fit.

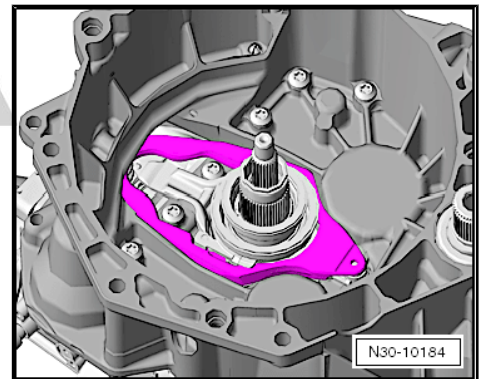

The small engaging bearing fits in only one position due to the 4 grooves.

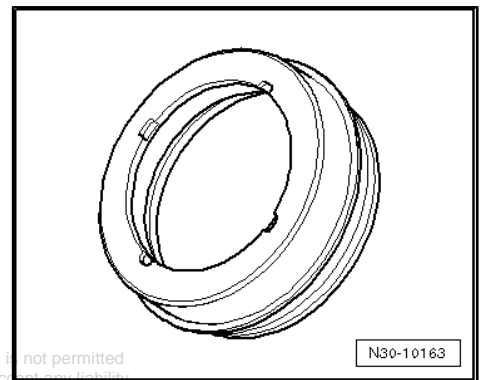

- Insert the engaging bearing and check the correct fit by "turning".

 **Note**

The 4 grooves must catch into the support.

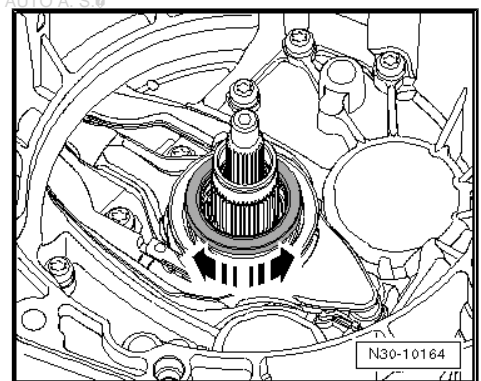



- The determined adjusting washers -arrows- must be located on both engaging bearings (fix with 3 drops of glue -AMV 195 KD1 01-).
- Turn back the spindle of the extractor -T10373- .

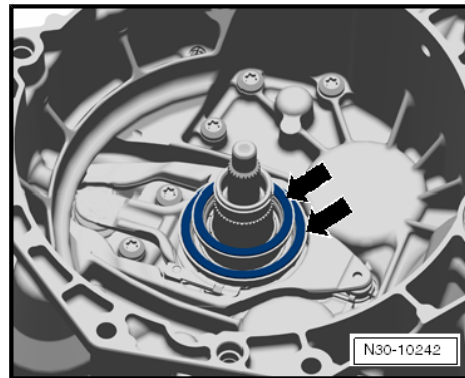

- Insert clutch with extractor -T10373- .

i Note

The clutch is self-adjusting. Vibrations can have a negative effect on the adjusting device. Do not let the clutch fall. The clutch should not fall into the gearbox when installing it.

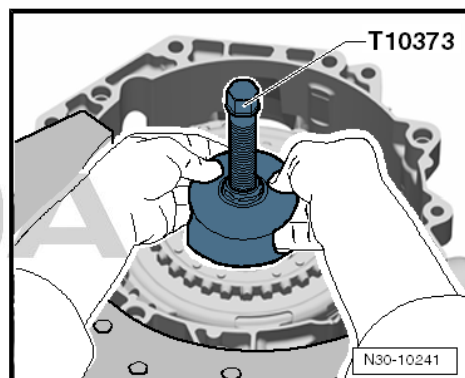

- Insert the supporting bridge -T10323- parallel to the flange of the clutch.
- Equalise distances, e.g using washers -B- with a total thickness of 15 mm.
- Attach the supporting bridge -T10323- with screws -A-.

i Note

Fasten screws -A- with nuts.

- Press the clutch downwards via the spindle.

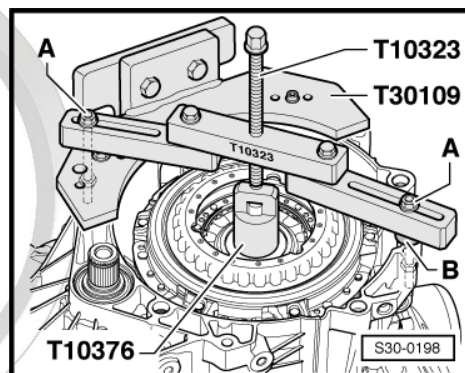

i Note

- ◆ *During press-in procedure, place a hand onto the clutch. A slight vibration can be felt. Vibration means that the clutch is pressed into the pressing position. In this way, it can be "detected" if the clutch is positioned up to the stop.*
- ◆ *The clutch is pressed in up to the stop if the circlip can be inserted.*

Protected by copyright. Copying for private or commercial purposes, in part or in whole, is not permitted unless authorised by ŠKODA AUTO A. S. ŠKODA AUTO A. S. does not guarantee or accept any liability for the content. Copyright by ŠKODA AUTO A. S.®

Fitting position of the circlip: the joint of the circlip is "smaller at the top".

ŠKODA

- Insert the new circlip -arrow-.

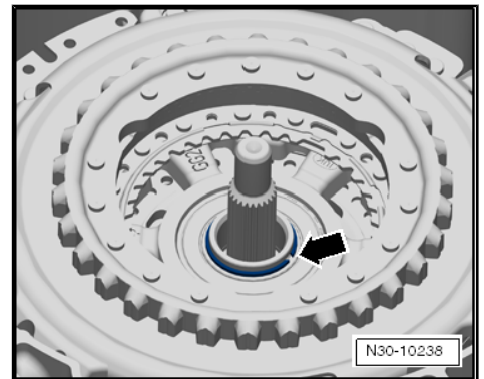
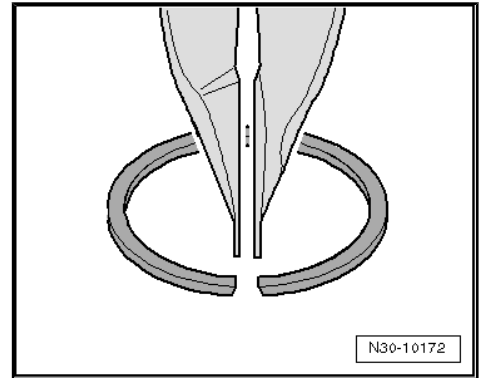

Insert hub:

Protected by copyright. Copying for private or commercial purposes, in part or in whole, is not permitted unless expressly permitted by SKODA AUTO A.S. SKODA AUTO is not responsible for any liability with respect to the correctness of information in this document. Copyright by SKODA AUTO A.S. 2009

The hub has a "large" tooth and therefore only fits in one position.

On the -engine side-, the "large" tooth has a marking -arrow-.

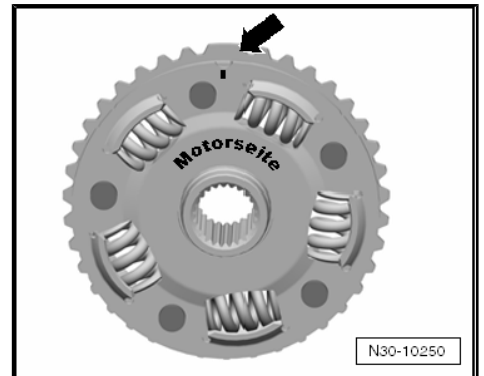

- Install the hub with the identification on the "large tooth" in such a way that it is flush with the identification on the drive plate -arrow-.

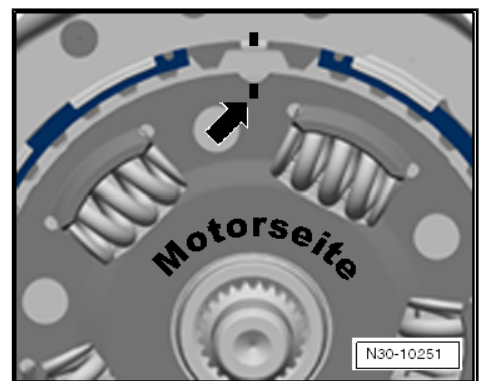



- Insert the circlip for the hub -arrow-.

Fitting position:

- The joint of the ring must point to the "hub" on the clutch.



- Turn the clutch by hand and while turning it pay attention to the "small" engaging lever.

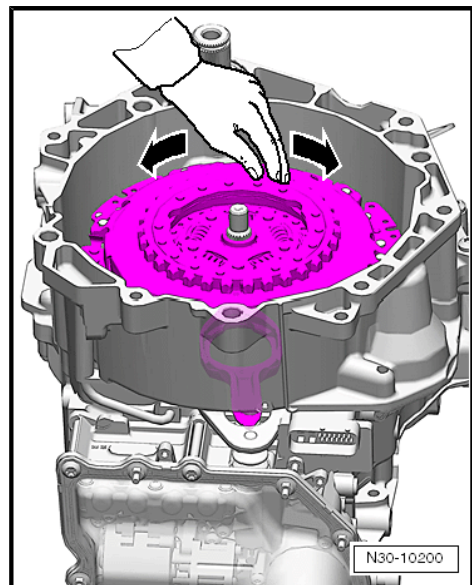
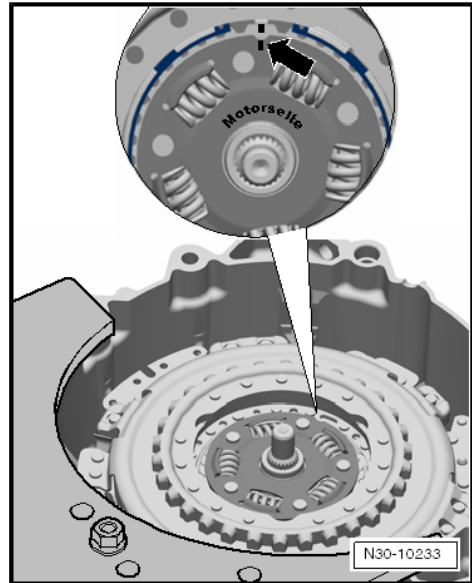

Protected by copyright. Copying for private or commercial purposes, in part or in whole, is not permitted without the prior written permission of ŠKODA AUTO a.s. ŠKODA AUTO does not guarantee or accept any liability for the use of this manual. All rights reserved. Copyright © ŠKODA AUTO a.s. 2010

While doing so, the engaging lever "in standstill" must remain in its position. It must neither move up nor down.

If the "small" engaging lever moves up and down, then the adjusting washer for the clutch "K 2" is not correctly inserted.

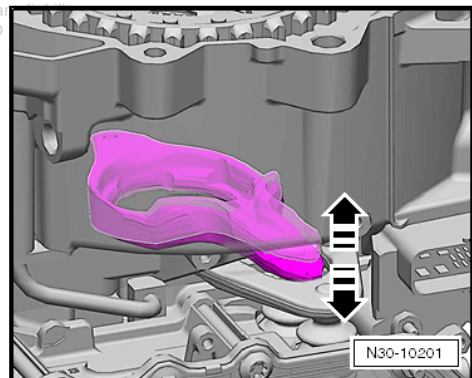



- In this case, remove the clutch again ⇒ [page 11](#) .
- Thoroughly check the adjusting washers -arrows-.
- The adjusting washers must be correctly inserted in their bearing. They should not be damaged.

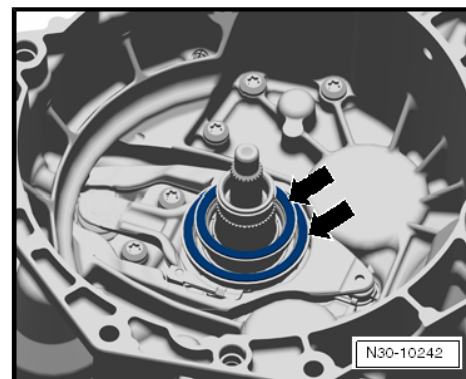

- Remove the screw plugs and position both ventilation caps -arrows- again.

Perform the [basic setting](#) after the gearbox has been fitted with the ⇒ Vehicle diagnosis, testing and information system VAS 5051.

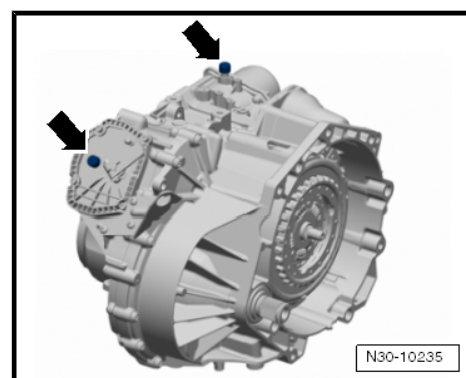

1.5 Install double clutch - “new design”

Special tools and workshop equipment required

- ◆ Extractor -T10373-
- ◆ Supporting bridge -T10323-
- ◆ Thrust piece -T10368-
- ◆ Thrust piece -T10376-
- ◆ Adhesive -AMV 195 KD1 01-

Do not oil or grease!



Note

The adjusting washer for the clutch “K1” is installed on the large bearing, the adjusting washer for the clutch “K2” is installed under the small bearing.

Before installing the clutch, the position of the engaging bearings “K 1 and K 2” must be adjusted ⇒ [page 21](#) .

- Insert the plastic support of the engaging levers and check for correct fit.

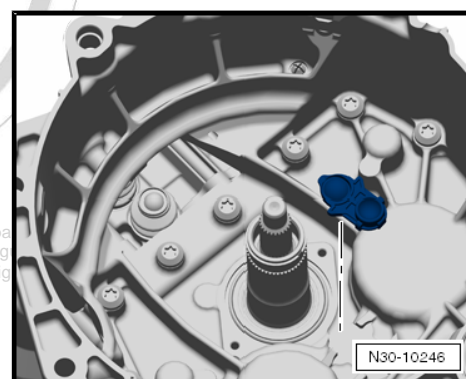

Protected by copyright. Copying for private or commercial purposes, in part or in full, is prohibited without the written permission of ŠKODA AUTO A. S. ŠKODA AUTO A. S. does not guarantee the correctness of information in this document. Copyright © ŠKODA AUTO A. S. 2010.



- Install small engaging lever with clamp.
- The sleeve with its retaining bracket fits only in one position.
- Check the correct fit of the engaging lever.
 - Screw down the engaging lever with 2 new screws.

Tightening torque: 8 Nm + 90°

i Note

The support of the engaging levers and the complete mechanism for the engaging bearings must be dry and free of oil or grease. If necessary, clean these component parts with a cloth.

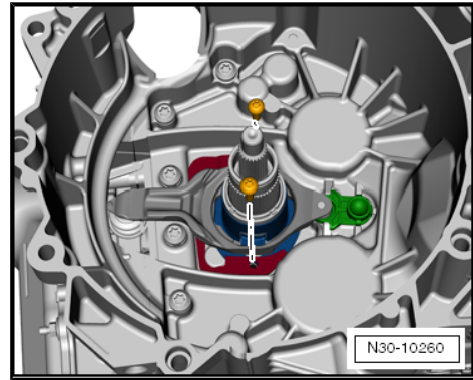

- Insert the second "larger" engaging lever.
- This "larger" lever is for the clutch "K 1".
- Check the correct position of both engaging levers.

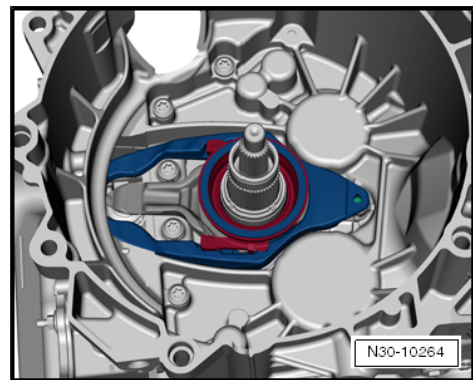

Caution

Before performing any further assembly, check whether the clutch must be adjusted.

Further assembly can only be performed once the clutch has been adjusted!

Adjust the positions of the engaging bearings => [page 21](#) .

- Insert the small engaging bearing -A- with the measured adjusting washer -B-.

The adjusting washer -B- belongs under the small engaging bearing -A-. Therefore, insert the adjusting washer first.

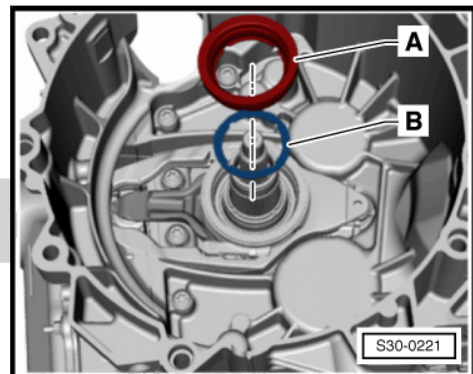

The small engaging bearing fits in only one position due to the 4 grooves.

If the clutch was replaced, the adjusting washer also belongs under the bearing.

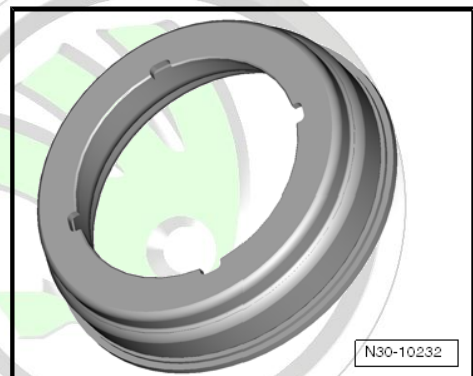

- While "turning" the bearing, check if it is correctly installed and the grooves are correctly positioned.

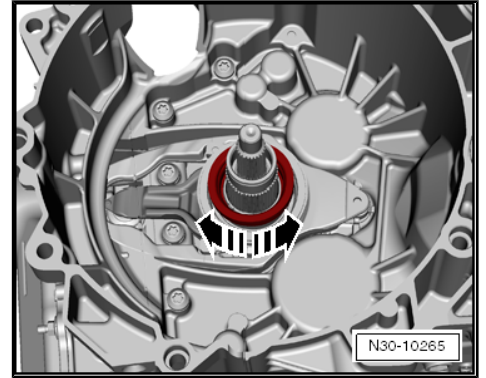

- Fix the adjusting washer -A- with 3 drops of glue -AMV 195 KD1 01- -arrows-.

This prevents that the washer slips out of its position when the clutch is inserted.

The large adjusting washer is used for the clutch "K 1", the small one is used for the clutch "K 2".

- Turn back the spindle of the extractor -T10373- .

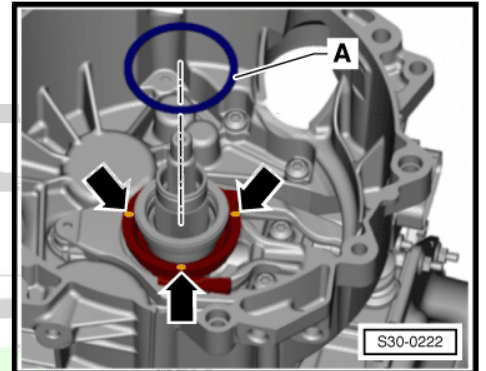

- Insert the clutch.
- Insert the clutch into the gearbox using the extractor -T10373- .
- "Turn back" the spindle beforehand.

 **Note**

The clutch is self-adjusting. Vibrations can have a negative effect on the adjusting device. Therefore do not let the clutch fall. Do not let the clutch fall into the gearbox when installing it.

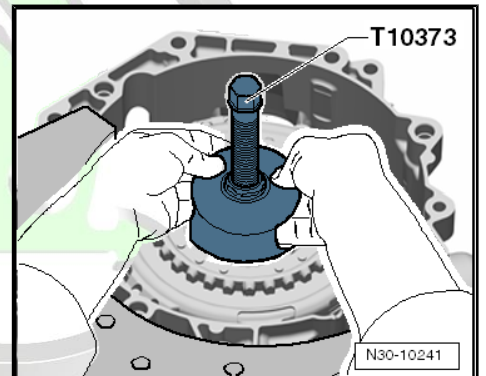

Protected by copyright. Copying for private or commercial purposes, in part or in whole, is not permitted unless authorised by ŠKODA AUTO A. S. ŠKODA AUTO A. S. does not guarantee or accept any liability with respect to the correctness of information in this document. Copyright by ŠKODA AUTO A. S. ©



- Position the supporting bridge -T10323- parallel to the flange of the clutch housing.
- Equalise distances, e.g using washers -B- with a total thickness of 15 mm.
- Attach the supporting bridge -T10323- with screws -A-.

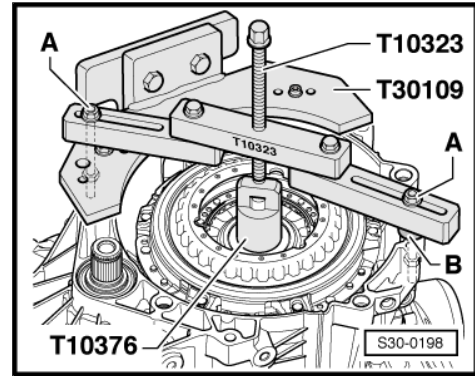

i Note

Fasten screws -A- with nuts.

- Press the clutch downwards via the spindle.

i Note

- ◆ *During press-in procedure, place a hand onto the clutch. A slight rattling can be felt. Rattling means that the clutch is pressed into its fitting position. In this way, it can be “detected” if the clutch is pressed in up to the stop.*
- ◆ *The clutch is pressed in up to the stop if the circlip can be inserted.*

Fitting position of the circlip: the joint of the circlip is “smaller at the top”.

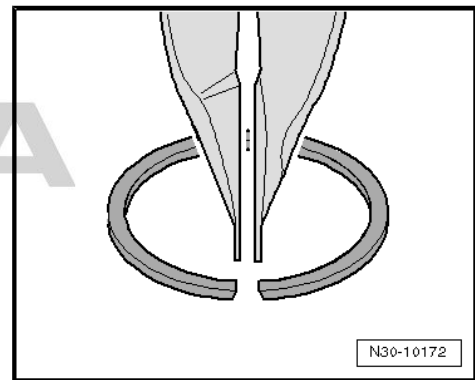

- Insert the new circlip -arrow-.

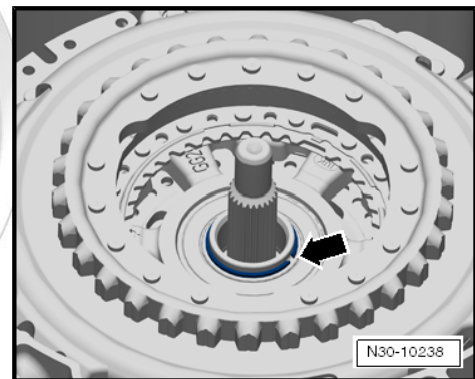

Protected by copyright. Copying for private or commercial purposes, in part or in whole, is not permitted unless authorised by ŠKODA AUTO A. S. ŠKODA AUTO A. S. does not guarantee or accept any liability with respect to the correctness of information in this document. Copyright by ŠKODA AUTO A. S. ©



- Turn the clutch against the extractor by hand so that the clutch is thus located in its fitting position.
- Only turn the clutch by hand, do not use any tool.

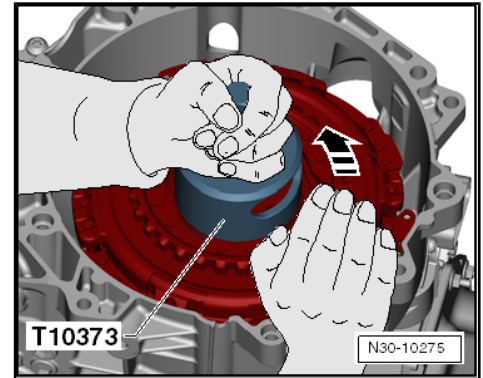

Only turn by hand. In this way, the clutch slips against the circlip. Do not use any further tool.

By pressing on the “clutch it is positioned at the bottom” on the drive shaft. The clutch should only be pulled up as far as necessary until it touches the circlip.

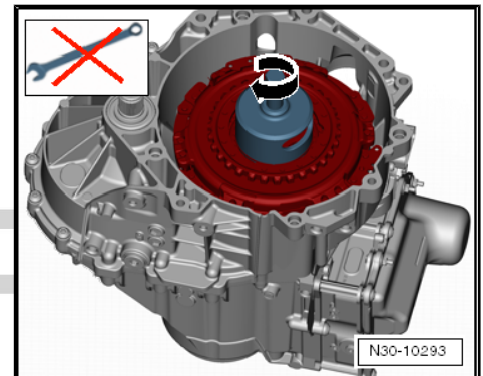

ŠKODA

Subsequently insert the hub:

The hub has a “large” tooth and therefore only fits in one position.

On the -engine side-, the “large” tooth has a marking -arrow-.

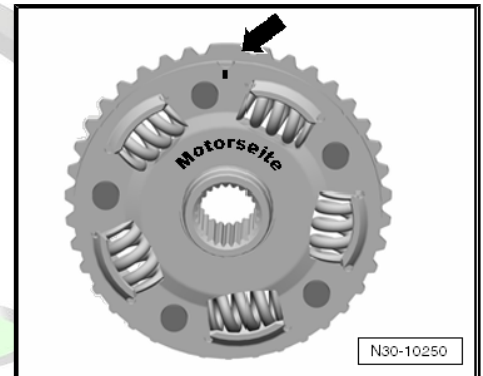

- Install the hub with the marking on the “large tooth” in such a way that it is flush with the marking on the drive plate -arrow-.

Protected by copyright. Copying for private or commercial purpose unless authorised by ŠKODA AUTO A. S. ŠKODA AUTO A. S. does not accept any liability with respect to the correctness of information in this document.

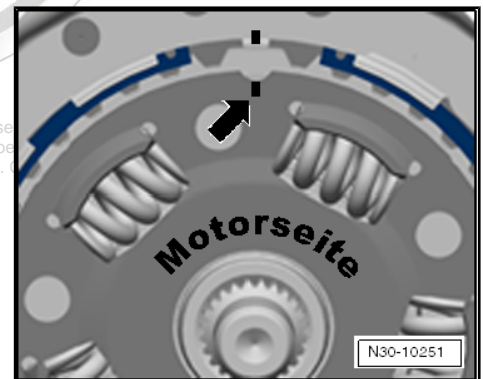



- Insert the circlip for the hub -arrow-.

Fitting location: The joint of the ring must point to the "lug" on the clutch.

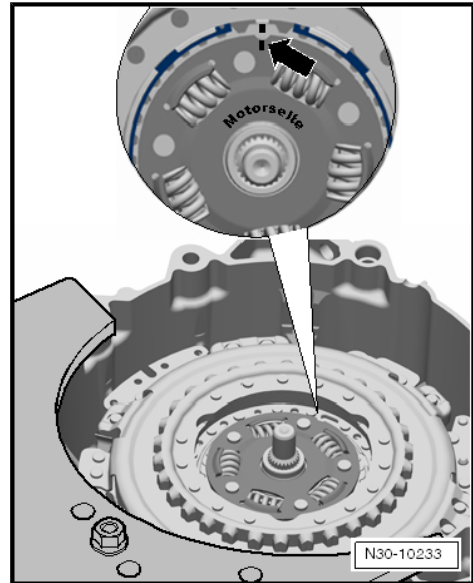

- Turn the clutch by hand and while turning it pay attention to the "small" engaging lever.

ŠKODA

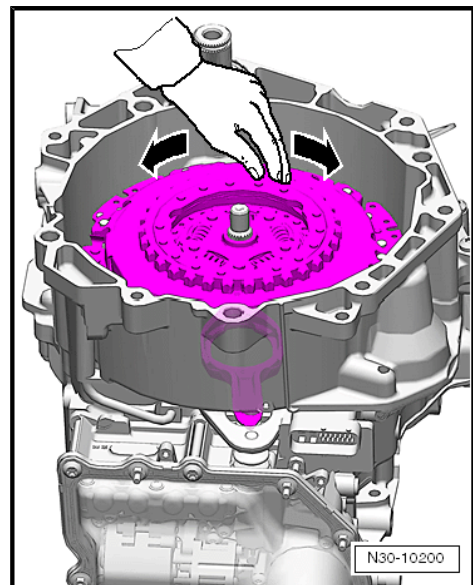

While doing so, the engaging levers must remain "still" in their position. They must not move up and down.

If an engaging lever moves up and down, the adjusting washer is not in its position.

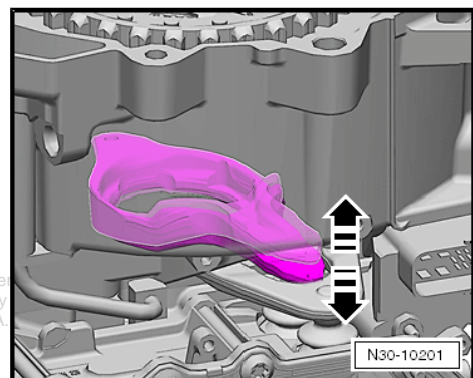

Protected by copyright. Copying for private or commercial purposes, in part or in whole, is not permitted unless authorised by ŠKODA AUTO A. S. ŠKODA AUTO A. S. does not guarantee or accept any responsibility with respect to the correctness of information in this document. Copyright by ŠKODA AUTO A. S.



- In this case, remove the clutch again ⇒ [page 11](#) .
- Have a close look at the adjusting washers -arrows-.
- The washers must be correctly positioned. They should not be damaged.

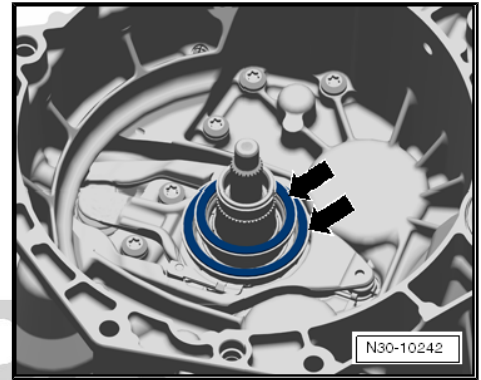

- Remove the screw plugs and position both ventilation caps -arrows- again.

Perform the [basic setting](#) after the gearbox has been fitted with the ⇒ Vehicle diagnosis, testing and information system VAS 5051.

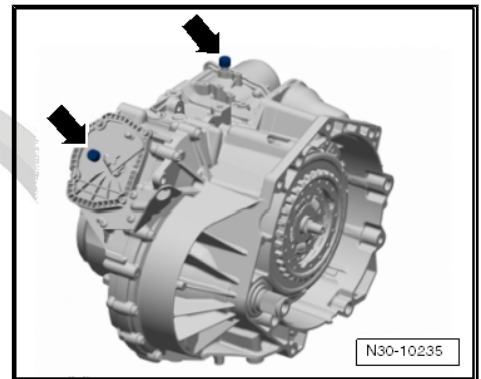

Protected by copyright. Copying for private or commercial purposes, in part or in whole, is not permitted unless authorised by ŠKODA AUTO A. S. ŠKODA AUTO A. S. does not guarantee or accept any liability with respect to the correctness of information in this document. Copyright by ŠKODA AUTO A. S. ©



34 – Control, housing

1 Electric/electronic components and fitting locations of the automatic gearbox DSG - 0AM

1 - Diagnostic connection

- ❑ Fitting location: Cover in driver's footwell

2 - Selector lever position indicator -Y6 -

- ❑ Fitting location: integrated in the dash panel insert
- ❑ a switched off gear display points to an emergency operation with deactivated gearbox control unit
- ❑ a fully lit gear display points to an emergency operation with activated gearbox control unit
- ❑ can only be replaced together with the dash panel insert ⇒ Electrical System ⇒ Rep. Gr. 90

3 - Cover for shift mechanism with lamp for selector lever scale illumination -L101-

- ❑ the lamp for selector lever scale illumination - L101- is integrated in the cover frame; fitting location ⇒ [page 46](#)
- ❑ the lamp for selector lever scale illumination - L101- is checked by self-diagnosis
- ❑ removing and installing ⇒ [page 55](#)

4 - Gearbox input r.p.m. sender -G182-

- ❑ Fitting location ⇒ [page 45](#)
- ❑ is checked by self-diagnosis
- ❑ Component part of the mechatronics for double clutch gearbox -J743-
- ❑ can only be removed and installed with the^o mechatronics for double clutch gearbox -J743- ⇒ [page 69](#)

5 - Mechatronics for double clutch gearbox -J743-

- ❑ Fitting location ⇒ [page 45](#)
- ❑ is checked by self-diagnosis
- ❑ removing and installing ⇒ [page 69](#)

6 - Selector lever lock solenoid -N110-

- ❑ Fitting location ⇒ [page 46](#)
- ❑ is checked by self-diagnosis

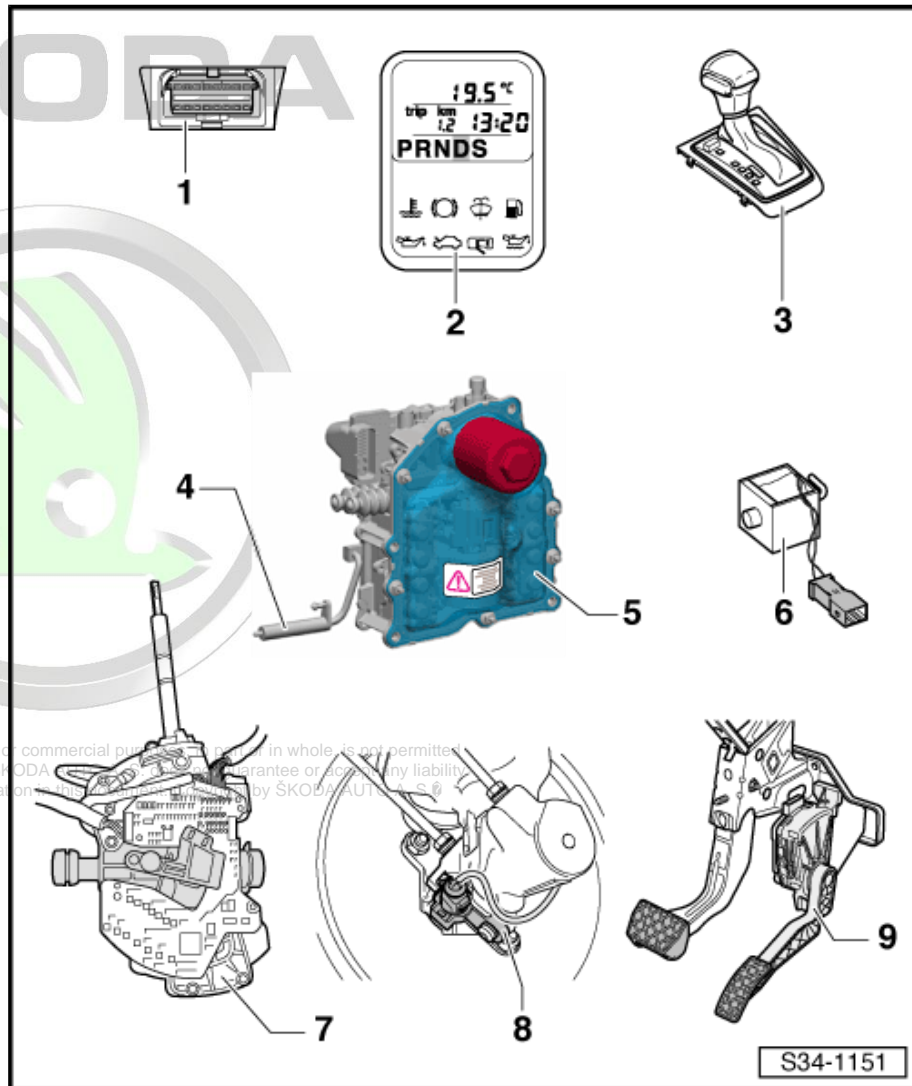

7 - Selector lever -E313- with Tiptronic switch -F189- , selector lever sensor control unit -J587- and selector lever switch locked in P -F319 -

- Fitting location ⇒ [page 46](#)
- is checked by self-diagnosis
- Tiptronic switch -F189- , selector lever sensor control unit -J587- and selector lever switch locked in P -F319 - are integrated into the shift mechanism.
- these components cannot be replaced separately; the removal and installation procedure is only possible together with the gearshift mechanism ⇒ [page 52](#)

8 - Brake light switch -F- and brake pedal switch -F47-

- Fitting location ⇒ [page 46](#)
- Signal transfer from engine control unit to gearbox control unit via CAN databus
- is checked by self-diagnosis
- removing and installing ⇒ Chassis ⇒ Rep. Gr. 46

9 - Kick-down switch -F8-

- Fitting location ⇒ [page 47](#)
- Signal transfer from engine control unit to gearbox control unit via CAN databus
- is checked by self-diagnosis
- removing and installing ⇒ Engine ⇒ Rep. Gr. 20

Mechatronics for double clutch gearbox -J743-

Fitting location: The mechatronics for double clutch gearbox -J743- is screwed onto the front of the gearbox housing.

The control unit is firmly integrated in the mechatronics for double clutch gearbox -J743- .

- ◆ is checked by self-diagnosis

The senders and the actuators are located in the mechatronics for double clutch gearbox -J743- . Further information on this can be found in ⇒ Self-study programme No. 75 ; Automatic gearbox DSG - 0AM .

Removing and installing the mechatronics for double clutch gearbox -J743- ⇒ [page 69](#) .

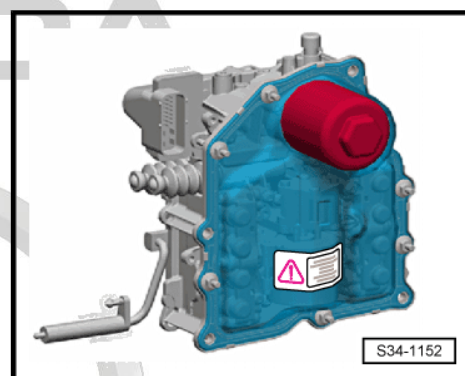

Gearbox input r.p.m. sender -G182-

Fitting location: The gearbox input r.p.m. sender -G182- is clipped onto the front of the gearbox housing. Slacken sender for removing and pull out in -direction of arrow-.

The gearbox input r.p.m. sender -G182- can only be replaced together with the mechatronics for double clutch gearbox -J743- ⇒ [page 69](#) .

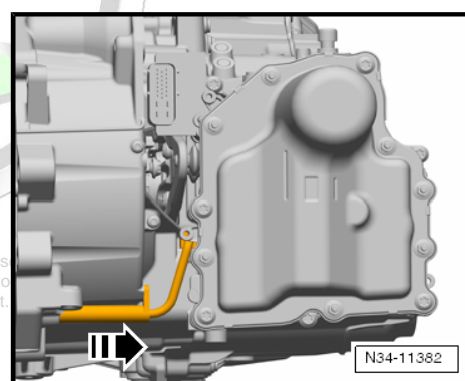

Protected by copyright. Copying for private or commercial purposes without authorisation by ŠKODA AUTO A. S. ŠKODA AUTO A. S. do not accept any responsibility with respect to the correctness of information in this document.



Selector lever lock solenoid -N110-

Fitting location up to 05.09: The selector lever lock solenoid -N110- -arrow- is located on the gearshift mechanism.

Fitting location as of 06.09: The selector lever lock solenoid -N110- -arrow- is located in the gearshift mechanism
⇒ [page 54](#) .

The selector lever lock solenoid -N110- is installed firmly in the gearshift mechanism and cannot be replaced individually. The removal and installation procedure is only possible together with the gearshift mechanism ⇒ [page 52](#) .

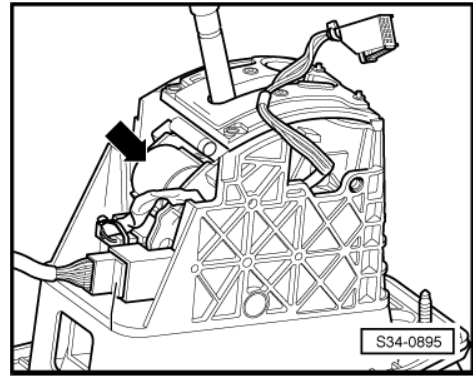

Lamp for selector lever scale illumination -L101-

Fitting location: The lamp for selector lever scale illumination -L101- -1- is integrated in the bottom side of the cover frame -2-.

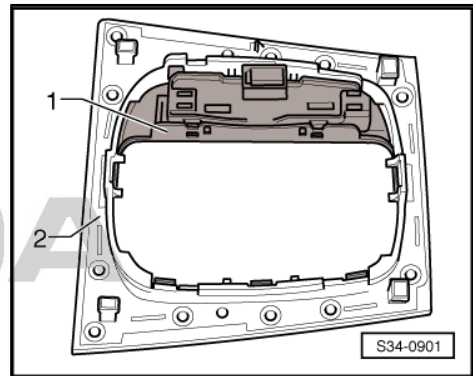

Selector lever -E313- with Tiptronic switch -F189- , selector lever sensor control unit -J587- and selector lever switch locked in P -F319-

Fitting location: Selector lever -E313- is integrated firmly into the shift mechanism.

Tiptronic switch -F189- , selector lever sensor control unit -J587- and selector lever switch locked in P -F319- are integrated firmly into the printed circuit board -arrow- of the shift mechanism (up to 05.09). A new shift mechanism is fitted as of 06.09, then the cover for the bottom shift mechanism can no longer be removed in this way.

These components cannot be replaced separately. The removal and installation procedure is only possible together with the gearshift mechanism ⇒ [page 52](#) .

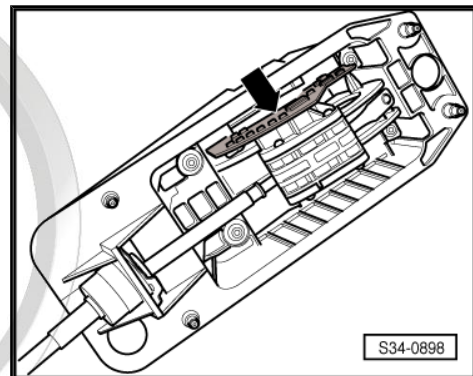

Brake light switch -F- and brake pedal switch -F47-

Fitting location: Brake light switch -F- and brake pedal switch -F47- -Pos. 3- are located on the master brake cylinder -Pos. 4-.

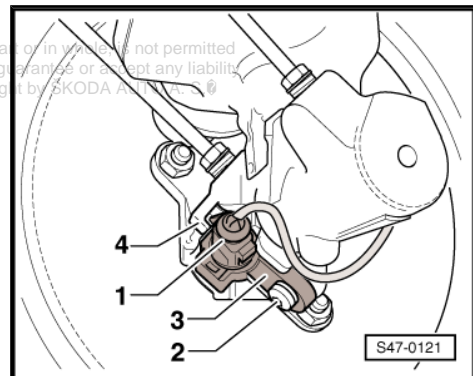



Kick-down switch -F8-

An initialised value of the accelerator pedal position sender - G79- / accelerator pedal position sender 2 -G185- (intergrated in the accelerator pedal module) is stored as a kick-down signal in the engine control unit.

Fitting location: Accelerator pedal position sender -G79- / accelerator pedal position sender 2 -G185- -arrow- are located on the foot controls.

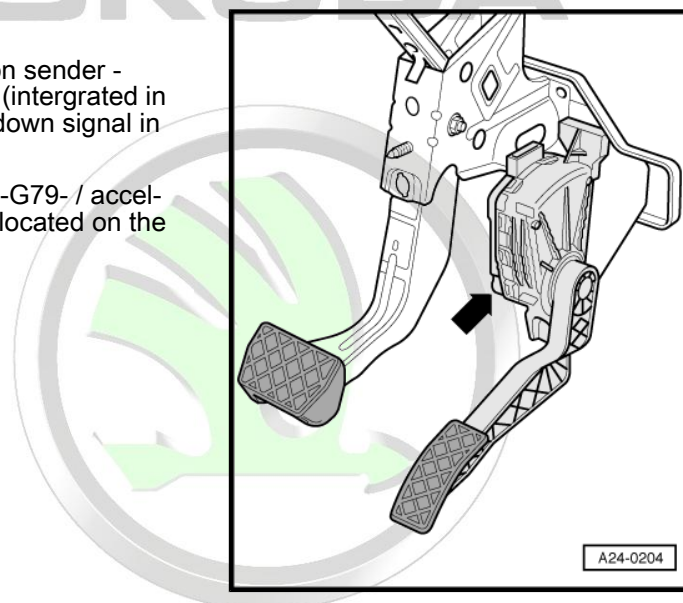

Protected by copyright. Copying for private or commercial purposes, in part or in whole, is not permitted unless authorised by ŠKODA AUTO A. S. ŠKODA AUTO A. S. does not guarantee or accept any liability with respect to the correctness of information in this document. Copyright by ŠKODA AUTO A. S. ©



2 Shift mechanism



WARNING

Before working on the engine when the engine is running, insert the selector lever in position "P" and apply handbrake.

2.1 Inspecting the gearshift mechanism

- ◆ In selector lever positions "S", "D", "R" and Tiptronic position it must not be possible to activate the starter.
- ◆ At speeds above 5 km/h and shifting in selector lever position "N" the selector lever lock solenoid must not engage and block the selector lever. Selector lever can be shifted in a driving position.
- ◆ At speeds below 5 km/h (virtual standstill) and shifting in selector lever position "N" the selector lever lock solenoid must only engage after approx. 1 s. The selector lever can only be moved from position "N" by activating the brake pedal.

Selector lever in position "P", button on selector lever pressed and ignition switched on

- Brake pedal is not operated

The selector lever is locked when the button is pressed and cannot be moved out of position "P". The selector lever lock solenoid blocks the selector lever.

- Brake pedal is operated

The selector lever lock solenoid releases the selector lever. It is possible to engage a driving gear position. Slowly shift selector lever from "P" through "R, N, D, S"; while doing so check whether the selector lever position in the dash panel insert corresponds with the actual selector lever position.

Selector lever in position "N", button on selector lever pressed and ignition switched on:

- Brake pedal is not operated

The selector lever is locked and cannot be moved out of position "N". The selector lever lock solenoid blocks the selector lever.

- Brake pedal is operated

The selector lever lock solenoid releases the selector lever. It is possible to engage a driving gear position.



Note

Shifting out of the position "N" to "D" by activating the brake pedal is also possible without pressing the button on the selector lever. From position "N" to "R" the button on the selector lever must be additionally pressed.

Selector lever in position "D", ignition switched on

The selector lever is locked and cannot be shifted from position "D" to position "S".

- Button pressed on selector lever

The selector lever is released and can be shifted from position "D" to position "S".

Selector lever in position "D", ignition and light switched on

- Selector lever in the Tiptronic gear leads to

The lighting up of the "D" on the lamp for selector lever scale illumination -L101- should go out and the "+" and "-" symbols should light up.

When the selector lever is put into the Tiptronic gate, the selector lever position indicator -Y6- in the dash panel insert should change from "P R N D S" to "7 6 5 4 3 2 1".

- Move selector lever in the Tiptronic gear to "+" and "-".

The display of the selector lever position "7 6 5 4 3 2 1" in the dash panel insert must indicate (change) a higher or a lower gear when shifting the selector lever to "+" or to "-".

If the gearshift mechanism does not function as described:

- Inspecting and adjusting the selector lever control cable ⇒ [page 49](#).
- Checking the ignition key lock ⇒ [page 51](#).

Selector lever position indicator

If all parts of the selector lever position display are lit, it indicates that the gearbox is in emergency operation mode.

2.2 Inspecting and adjusting the selector lever control cable

Copyright. Copying for private or commercial purposes, in part or in whole, is not permitted unless authorised by ŠKODA AUTO A. S. ŠKODA AUTO A. S. does not guarantee or accept any liability with respect to the correctness of information in this document. Copyright by ŠKODA AUTO A. S. ©

2.2.1 Inspect setting of selector lever control cable

- The gearshift mechanism is checked ⇒ [page 48](#).
- Pull selector lever out of position "P" with the button pressed, approx. 5 mm to the rear and hold, do not shift into position "R".
- Release the selector lever.
- The selector lever must automatically jump back again into the position "P"
- If this is not the case, then the gearshift mechanism must be set ⇒ [page 50](#).
- Shift selector lever to position "N".
- Pull selector lever out of position "N" with the button pressed, approx. 5 mm to the rear and hold, do not shift into position "D".
- Release the selector lever.
- The selector lever must automatically jump back again into the position "N"
- If this is not the case, then the gearshift mechanism must be set ⇒ [page 50](#).
- Pull selector lever out of position "N" with the button pressed, approx. 5 mm to the front and hold, do not shift into position "R".
- Release the selector lever.
- The selector lever must automatically jump back again into the position "N"



- If this is not the case, then the gearshift mechanism must be set ⇒ [page 50](#) .

2.2.2 Adjusting selector lever control cable

The selector lever control cable must always be set, if:

- ◆ the selector lever control cable was removed from the gearbox.
 - ◆ Remove and install engine and (or) gearbox.
 - ◆ Removed and installed parts of the unit mounting.
 - ◆ the shift cable or the gearshift mechanism was removed and installed.
 - ◆ The engine/gearbox were changed in their position, for example were installed free of tension.
- Remove air filter ⇒ Engine ⇒ Rep. Gr. 24 .
 - Check if the lock washer -arrow- is correctly fitted and secured towards the bottom.



Note

The lock washer -arrow- must be replaced after removing.

- Shift selector lever from "P" to "S".
- Check the protective cover at the front gearshift mechanism on the selector lever control cable for damage. The selector lever control cable must be replaced if damaged.
- Gearshift mechanism and selector lever control cable must move smoothly when shifting gears. If this is not the case, replace the selector lever control cable or repair the gearshift mechanism ⇒ [page 52](#) .
- Shift selector lever in the vehicle into position "P".
- Switch off ignition.
- Release screw -arrow-.



Note

If the clamping screw -arrow- is released, the selector lever of the gearshift mechanism must remain in position "P", otherwise the setting is not correct.

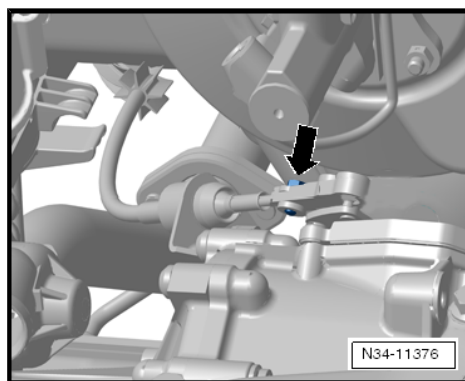
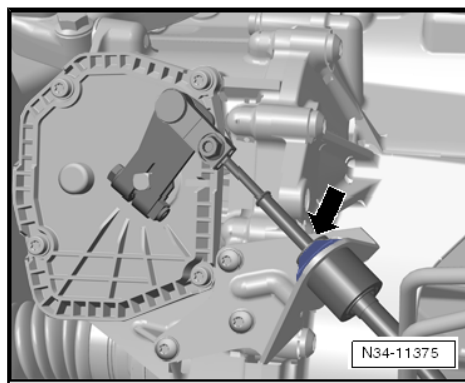
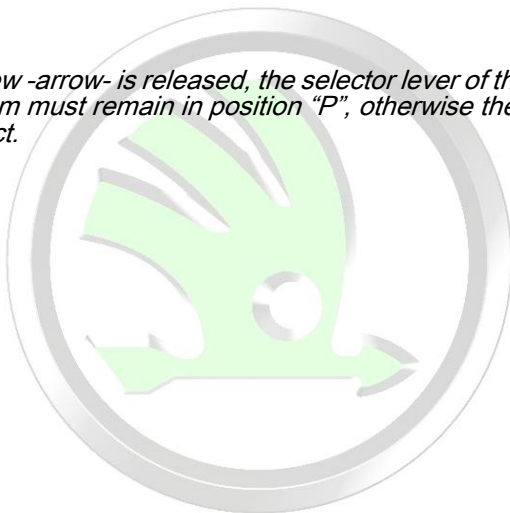



- Position gearshift lever at gearbox in "P". To do so, press the gearshift lever in -direction of arrow- in the direction towards the cable support.

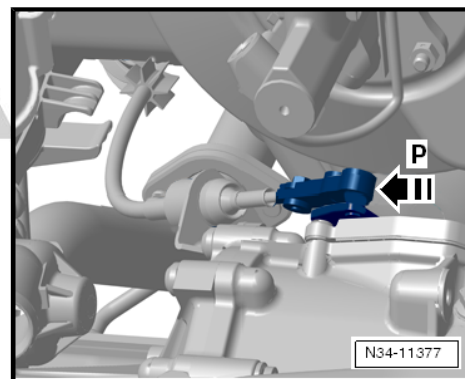

The figure shows the gearbox "from the rear". -P- is in the direction towards the cable support.

- Turn both front wheels in one direction, e.g. by rolling the vehicle forwards, until the parking lock in the gearbox engages into the parking gear.
- Only if both front wheels cannot be simultaneously turned in one direction, the parking lock is engaged.
- Slightly move the selector lever towards the front and rear, without shifting into another selector lever position.

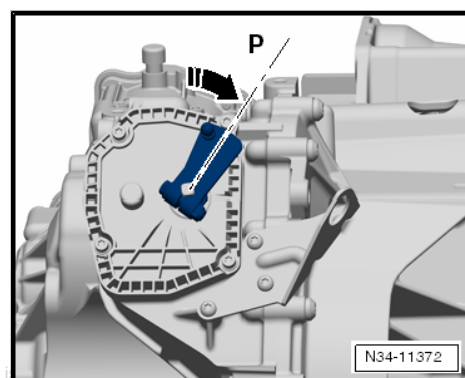

Note Protected by copyright. Copying for private or commercial purposes, in part or in whole, unless authorised by ŠKODA AUTO A. S. ŠKODA AUTO A. S. does not guarantee or accept any liability with respect to the correctness of information in this document. Copyright by ŠKODA AUTO A. S. ©

The selector lever control cable is therefore released.

- Tighten screw -arrow- at selector lever cable without jolting to tightening torque.

Tightening torque

- ◆ up to 11.08 tightening torque 13 Nm
- ◆ as of 12.08 tightening torque 12 Nm



Note

Pay attention when tightening the screw -arrow- that the selector lever control cable no longer shifts.

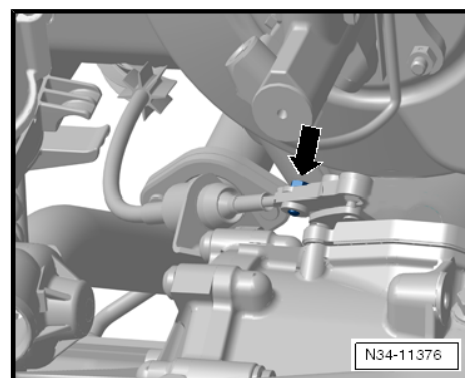

- Install air filter ⇒ Engine ⇒ Rep. Gr. 24 .

2.3 Check operation of the ignition key anti-removal lock

- After reaching the position "ignition on" turn the key slightly to the right (do not start engine).
- Depress brake pedal and hold pressed.
- When the lock button is pressed at the selector lever grip, the selector lever must be moved out of the position "P" without "rubbing".
- Switch off ignition.
- The key cannot be withdrawn from the ignition starter switch in any other selector lever position except in the position "P".
- Shift selector lever into position "P".
- Withdraw ignition key.



- Only withdraw the key from the ignition starter switch if the selector lever is in position "P".
- The selector lever cannot be shifted out of position "P" when the button is pressed and the brake pedal is actuated.

If the ignition key removal lock does not function as described:

- ◆ Inspecting and adjusting the selector lever control cable
⇒ [page 49](#).
- ◆ Check the vehicle with the vehicle diagnosis, measurement and information system -VAS 5051B- in the function "targeted fault finding".

2.4 Summary of components - Shift mechanism up to 05.09 ("old shifting")

1 - Cover with handle

- Remove the cover
⇒ [page 55](#)
- for the emergency release only the cover needs to be unclipped
⇒ [page 65](#)
- the symbol insert and the circuit board with the lamp for selector lever scale illumination - L101- are integrated in the cover

2 - Open warm-type clamp

- always replace ⇒ Electronic Catalogue of Original Parts
- tighten using hose binding claw -V.A.G 1275-

3 - Selector lever and shift mechanism

- with selector lever lock solenoid -N110-
- Emergency release
⇒ [page 65](#)
- removing and installing
⇒ [page 57](#)
- after the installation adjust the selector lever control cable ⇒ [page 49](#)

4 - Screw with spring, 3 Nm

5 - Bolt

- removing ⇒ [page 61](#)
- do not grease

6 - Lock washer

- always replace after removing ⇒ Electronic Catalogue of Original Parts

7 - Nut, 9 Nm

- 4 pieces

8 - Shift housing

- with gasket

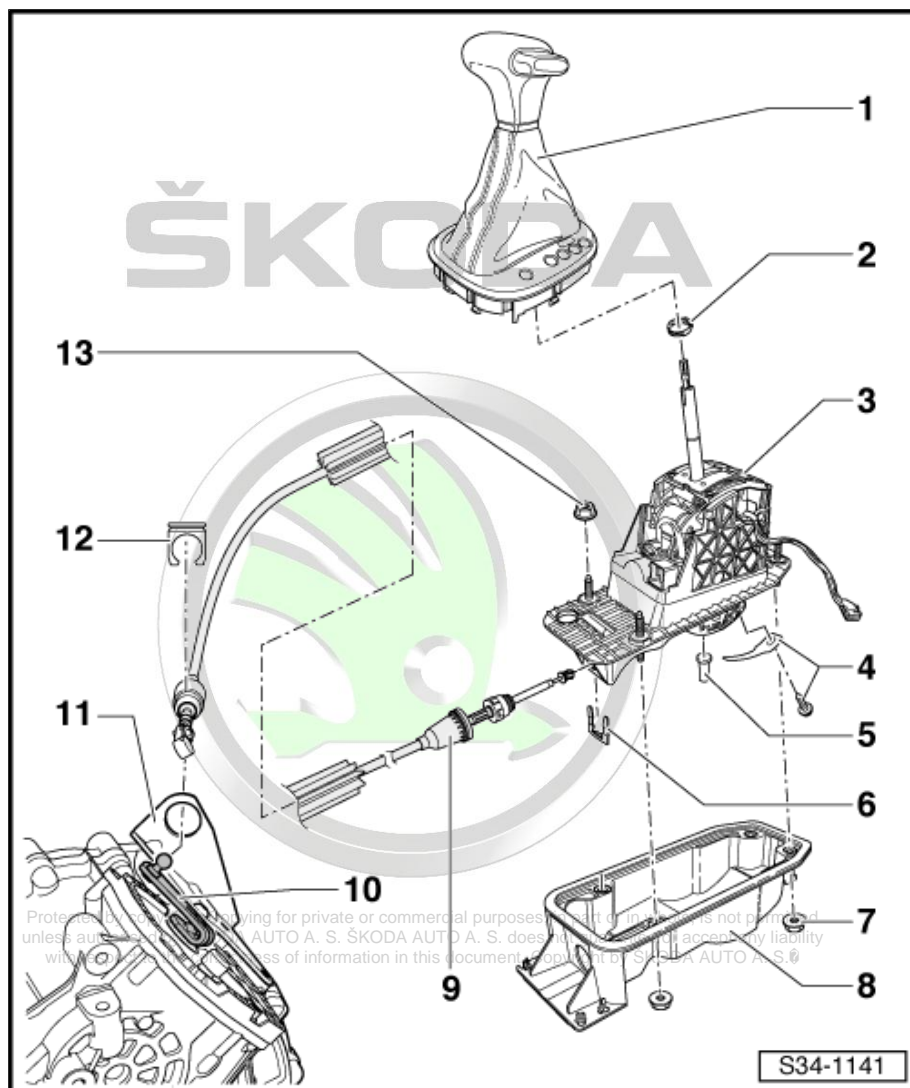



9 - Selector lever control cable

- Do not grease selector lever control cable
- removing and installing ⇒ [page 61](#)
- testing and adjusting ⇒ [page 49](#)

10 - Gearshift lever

11 - Cable support

- for selector lever control cable

12 - Lock washer

- always replace after removing ⇒ Electronic Catalogue of Original Parts
- when installing, make sure that it locks correctly into place

13 - Nut, 9 Nm

- 4 pieces

ŠKODA



Protected by copyright. Copying for private or commercial purposes, in part or in whole, is not permitted unless authorised by ŠKODA AUTO A. S. ŠKODA AUTO A. S. does not guarantee or accept any liability with respect to the correctness of information in this document. Copyright by ŠKODA AUTO A. S. ©



2.5 Summary of components - Shift mechanism as of 06.09 ("new shifting")



Note

The selector lever control cable was replaced as a separate component part up to vehicle production date 05.09 ("old shifting") ⇒ [page 52](#). As of production date 06.09 ("new shifting") this is no longer possible, the selector lever control cable Pos. 10 must not be removed (separated) from the shift mechanism Pos. 3, it must be replaced together as one component part ⇒ *Electronic Catalogue of Original Parts*.

1 - Cover with handle

- Remove the cover ⇒ [page 55](#)
- for the emergency release only the cover needs to be unclipped ⇒ [page 65](#)
- the symbol insert and the circuit board with the lamp for selector lever scale illumination - L101- are integrated in the cover

2 - Open warm-type clamp

- always replace ⇒ *Electronic Catalogue of Original Parts*
- tighten using hose binding claw -V.A.G 1275-

3 - Selector lever and shift mechanism

- with selector lever lock solenoid -N110-
- Emergency release ⇒ [page 65](#)
- removing and installing ⇒ [page 57](#)
- after the installation adjust the selector lever control cable ⇒ [page 49](#)
- Remove the shift mechanism from the shift housing ⇒ [page 55](#)

4 - Screw

5 - Shift housing with gasket

- Remove shift housing ⇒ [page 55](#)

6 - Nut, 25 Nm

- 4 pieces

7 - Gearshift lever

8 - Cable support

- for selector lever control cable

9 - Lock washer

- always replace after removing ⇒ *Electronic Catalogue of Original Parts*

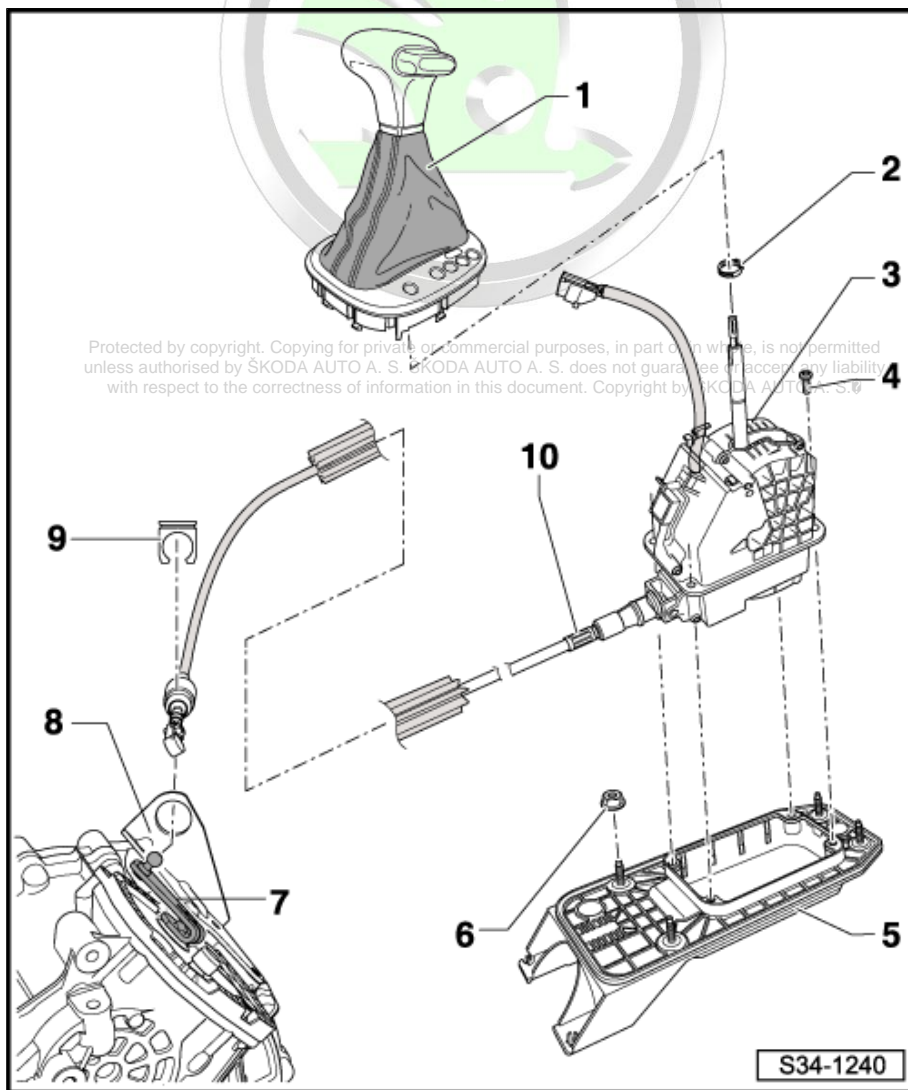

10 - Selector lever control cable



Note

The selector lever control cable must not be removed from the shift mechanism Pos. 3, it must be replaced together as one component part ⇒ Electronic Catalogue of Original Parts .

- ❑ Do not grease selector lever control cable
- ❑ remove from the shift housing and install ⇒ [page 55](#)
- ❑ testing and adjusting ⇒ [page 49](#)

Remove the shift mechanism together with the selector lever control cable from the shift housing

Remove the shift mechanism -A- together with the selector lever control cable -C- from the shift housing -B- in -direction of arrow-. To do so, unscrew 4 screws Pos. 4 (fig. S34-1240) from the shift housing ⇒ [page 54](#) .

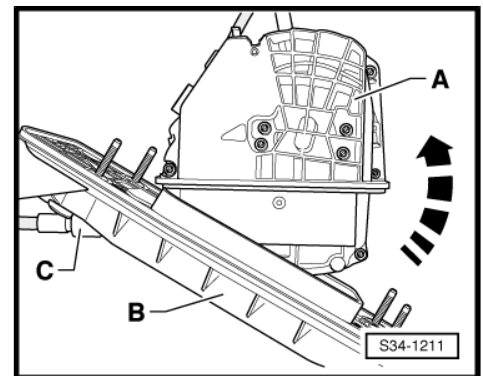

2.6 Removing and installing the handle and cover for the shift mechanism

Special tools and workshop equipment required

- ◆ Hose binding claw -V.A.G 1275-
- ◆ Release tool -T30098-

2.6.1 Removing

- Shift selector lever to position "N".
- Switch off ignition.
- Release the front right cover -arrow- using the release tool -T30098- . Then release the rear right and centre cover -arrow-.

Carefully slacken the cover.

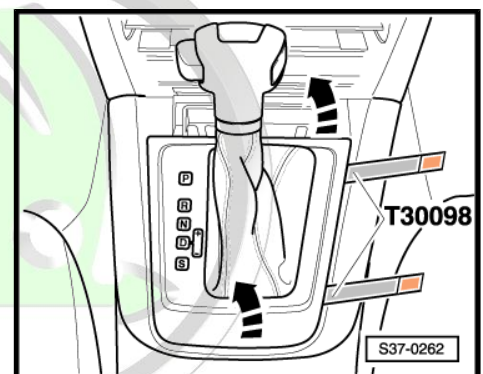



- Before removing the handle pull out lock button over its pressure point and secure it with a cable strap or a suitable wire. This can prevent that the button is inadvertently pressed into the handle.

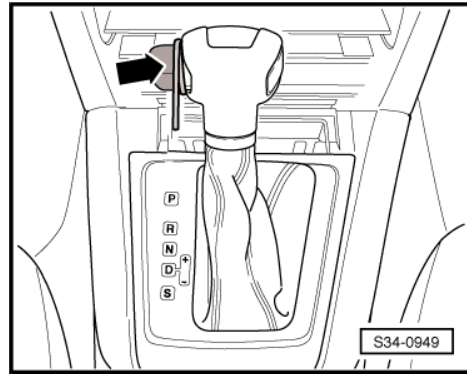

- Release plug connection -C- from the lamp for selector lever scale illumination -L101- and disconnect.

Note

- ◆ Ignore pos. -A-, -B- and -1-.
- ◆ As of production date 06.09 the shift mechanism is changed, the 4-pin plug connection -B- and the selector lever lock solenoid -N110- -1- are already located in the shift mechanism => [page 54](#).

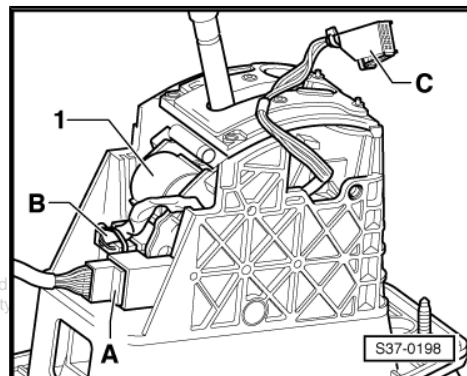

- Open the warm-type clamp -arrow- below the handle and pull off handle with cover.

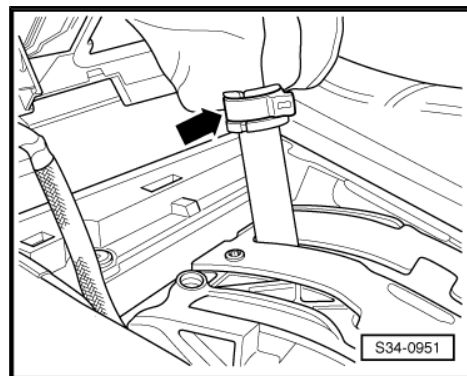

2.6.2 Install

Installation is performed in the reverse order, pay attention to the following points:

Note

- ◆ *The lock button must be fully pulled out for installing the selector lever grip. Then the grip must be secured using a cable strap -arrow- or with the assembly aid which was factory-delivered together with the new grip.*
- ◆ *If the lock button is not secured, it can no longer be pulled out of the selector lever grip using mechanical auxiliary tools. The lock button can be pulled out by positioning the gun with compressed air underneath the grip.*
- Fit the selector lever grip completely onto the selector lever with a new warm-type clamp - with the lock button towards the driver.
- During this procedure, the grip must latch in the annular groove on the selector lever.
- Remove cable strap or assembly aid. After the removal, the lock button actuator engages into the vertical groove on the selector lever. If necessary, press the lock button into the selector lever grip.

Tighten warm-type clamp using hose binding claw .

- Insert the plug connection -C- for lamp for selector lever scale illumination -L101- .

Note

- ◆ *When inserting the plug connection -C- ensure that the contact pins of the lamp for selector lever scale illumination -L101- are not bent and that the retaining lugs of the cover do not break off.*
- ◆ *Ignore pos. -A-, -B- and -1-.*
- ◆ *As of production date 06.09 the shift mechanism is changed, the 4-pin plug connection -B- and the selector lever lock solenoid -N110- -1- are already located in the shift mechanism => [page 54](#) .*

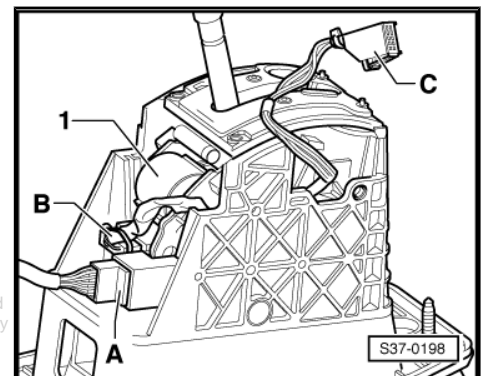
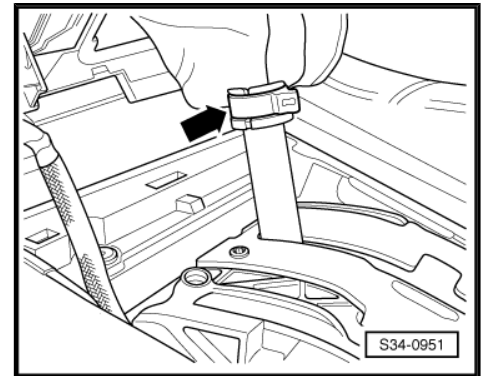

2.7 Removing and installing shift mechanism

Special tools and workshop equipment required

- ◆ Removal tool for the inner lining of the door panel -MP8-602/1-

2.7.1 Removing

- Removing the handle and cover for the shift mechanism => [page 55](#) .
- Shift selector lever into position "P".
- Switch off ignition.

**Note**

If the battery earth strap is disconnected and connected, carry out certain additional operations ⇒ Electrical System ⇒ Rep. Gr. 27.

- Disconnect the battery-earth strap with the ignition off ⇒ Electrical System ⇒ Rep. Gr. 27 .
- Remove ashtray or storage area in front of the shift mechanism ⇒ Body Work ⇒ Rep. Gr. 68 .
- Remove the centre console and air guide ⇒ Body Work ⇒ Rep. Gr. 68 .
- Pull out the plug connector housing of the plug connection -A- towards the front.
- Disconnect plug connection -A- from the shift mechanism to the vehicle wiring harness.

**Note**

- ◆ Ignore pos. -B-, -C- and -1-.
- ◆ As of production date 06.09 the shift mechanism is changed, the 4-pin plug connection -B- and the selector lever lock solenoid -N110- -1- are already located in the shift mechanism ⇒ [page 54](#) .
- Remove air filter ⇒ Engine ⇒ Rep. Gr. 24 .
- Expose the selector lever control cable -A- from the gearbox shift lever with the removal tool for the inner lining of the door panel -MP8-602/1- .

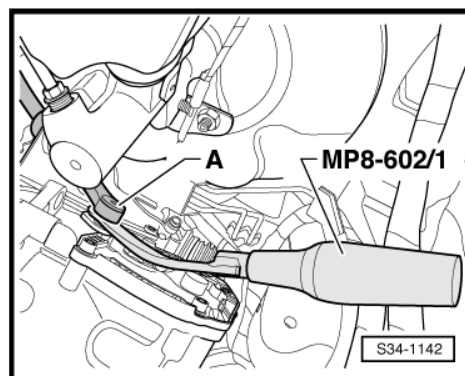
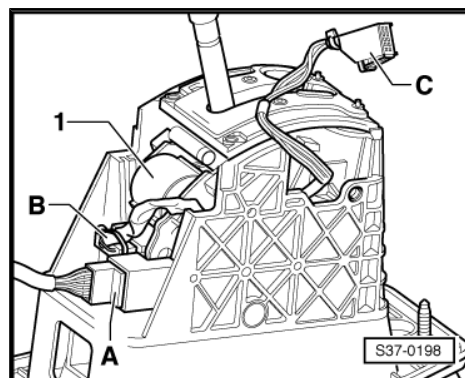

- Remove the lock washer -arrow- for the selector lever control cable, the selector lever control cable must be left in the fitting position.

**Note**

- ◆ The lock washer -1- of the selector lever control cable must always be replaced ⇒ Electronic Catalogue of Original Parts .
- ◆ Do not bend or buckle selector lever control cable.
- ◆ Do not press the selector lever control cable out of the cable support towards the rear. The selector lever control cable is only unclipped out of the cable support when removing the gearshift mechanism.

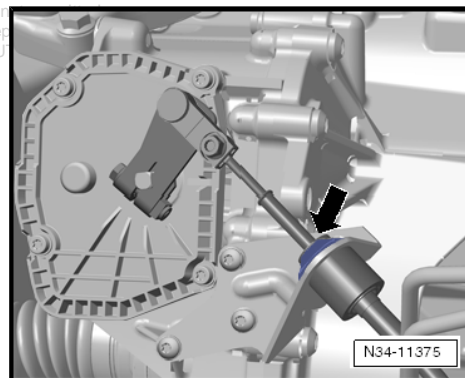

- Raise vehicle.



- Remove the rear tunnel bridge -1- and the front tunnel bridge -2- from the body (if present).
- Detach the bracket -3- for the exhaust system from the assembly carrier.
- Release double clamp -4-.

i Note

- ◆ *The decoupling element in the pre-exhaust pipe should not be bent by more than 10° - risk of damage.*
- ◆ *A second mechanic is needed to remove the rear part of the exhaust system.*

- Remove the exhaust tailpipe -5- from the double clamp ⇒ Engine ⇒ Rep. Gr. 26 .
- Slacken the trim panels for the underfloor on left -6- and right -7- from the body.
- Unclip lambda probe cable at heat shield.
- Remove the heat shield below the shift mechanism towards the rear, to do so slacken the clips -arrows-.

i Note

A second mechanic is needed under the vehicle to remove the shift mechanism.

Protected by copyright. Copying for private or commercial purposes, in part or in whole, is prohibited without the written permission of ŠKODA AUTO A. S. ŠKODA AUTO A. S. does not guarantee the accuracy of the information in this document. Copyright by ŠKODA AUTO A. S.

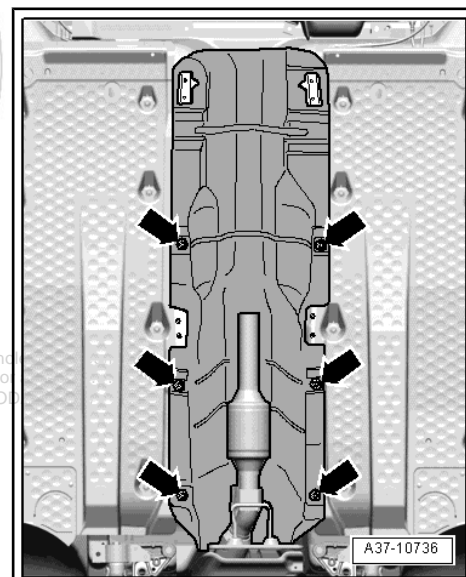
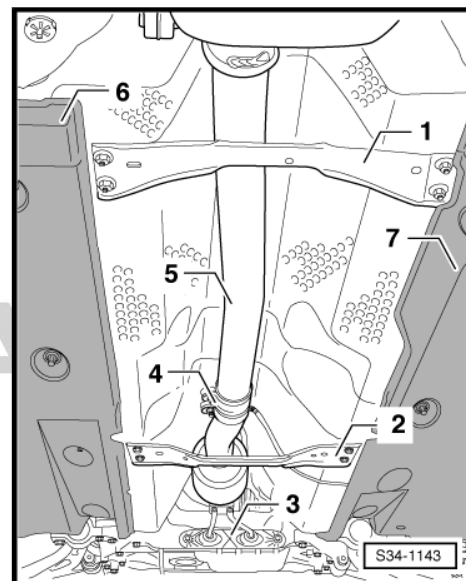

- Unscrew nuts -1- and -2-.
- Remove the shift mechanism together with the selector lever control cable downwards. When doing this, unclip the selector lever control cable from the cable support.

i Note

Do not bend or buckle selector lever control cable.

The shift mechanism (only vehicles up to production date 05.09) ("old shifting" ⇒ [page 52](#)) can also be replaced without selector lever control cable, to do so the selector lever control cable must be separated from the shift mechanism, remove the selector lever control cable ⇒ [page 61](#) .

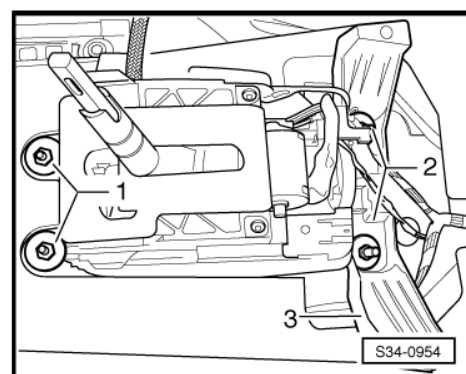

2.7.2 Install

Installation is performed in the reverse order, pay attention to the following points:

**Note**

Do not bend or buckle selector lever control cable.

- Insert the shift mechanism and tighten the rear nuts -1- by hand.
- Mount the strut for centre console -3- onto the shift mechanism as illustrated in the fig.
- Tighten nuts -1- and -2- to tightening torque.

Tightening torques of screws or nuts as well as the instruction, if the screws or nuts have to be replaced:

- ◆ Vehicles up to production date 05.09 ("old shifting")
⇒ [page 52](#)
- ◆ Vehicles as of production date 06.09 ("new shifting")
⇒ [page 54](#)

The fitting together of the plug connection -A- must not be performed, if the plug connector housing is latched into the shift mechanism. When fitting together (high resistance because of the spring) the catch of the plug connector housing breaks off.

- Connect plug -A- and plug connector housing and then latch into the shift mechanism.

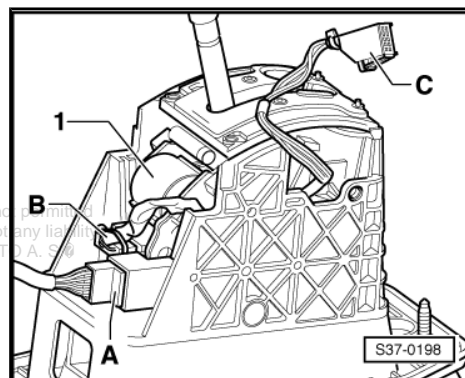
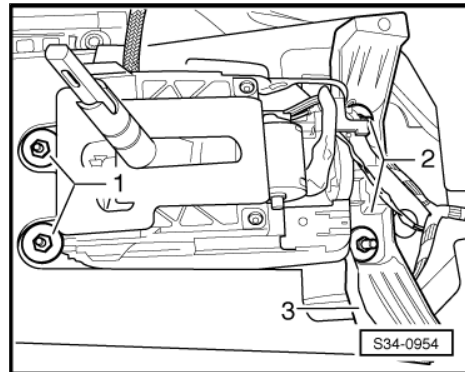
**Note**

As of production date 06.09 the shift mechanism is changed, the 4-pin plug connection -B- and the selector lever lock solenoid -N110- -1- are already located in the shift mechanism
⇒ [page 54](#).

- Install the air guide and the centre console ⇒ Body Work ⇒ Rep. Gr. 68 .
- Install ashtray or storage area in front of the shift mechanism ⇒ Body Work ⇒ Rep. Gr. 68 .
- Installing the handle and cover for the shift mechanism
⇒ [page 55](#) .
- Connect earth strap of battery ⇒ Electrical System ⇒ Rep. Gr. 27 .

**Note**

If the battery earth strap is disconnected and connected, carry out certain additional operations ⇒ Electrical System ⇒ Rep. Gr. 27 .

- Carefully press the selector lever control cable -2- onto the lever/gearshift shaft of the gearbox and secure in the cable support with a new lock washer -1-.
- Check operation of the ignition key anti-removal lock
⇒ [page 51](#)
- Then adjust the selector lever control cable ⇒ [page 49](#) .
- Install air filter ⇒ Engine ⇒ Rep. Gr. 24 .
- Inspect gearshift mechanism ⇒ [page 48](#) .
- Install the heat shield below the shift mechanism and fasten the trim panels for the underfloor on the body ⇒ Body Work ⇒ Rep. Gr. 50 .
- Install exhaust system and align free of stress ⇒ Engine ⇒ Rep. Gr. 26 .
- Install tunnel bridges below the exhaust system ⇒ Engine ⇒ Rep. Gr. 26 .

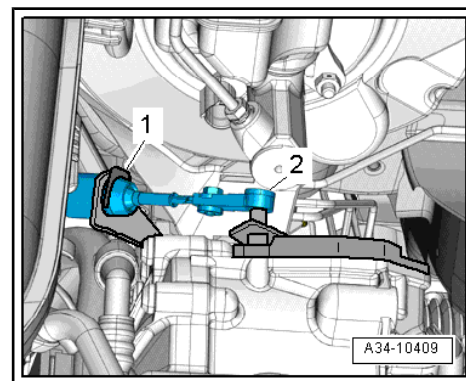

2.8 Removing and installing the selector lever control cable

Special tools and workshop equipment required

- ◆ Removal tool for the inner lining of the door panel -MP8-602/1-



Note

The selector lever control cable was replaced as a separate component part up to vehicle production date 05.09 ("old shifting") ⇒ [page 52](#) . As of production date 06.09 ("new shifting") this is no longer possible, the selector lever control cable must not be removed (separated) from the shift mechanism, it must be replaced together as one component part ⇒ Electronic Catalogue of Original Parts .

2.8.1 Removing

- Shift selector lever into position "S".

Vehicles up to production date 05.09 ("old shifting")

- Switch off ignition.
- Remove air filter ⇒ Engine ⇒ Rep. Gr. 24 .
- Expose the selector lever control cable -A- from the gearbox shift lever with the removal tool for the inner lining of the door panel -MP8-602/1- .

Protected by copyright. Copying for private or commercial purposes, in part or in whole, is not permitted unless authorised by ŠKODA AUTO A. S. ŠKODA AUTO A. S. does not guarantee or accept any liability with respect to the correctness of information in this document. Copyright by ŠKODA AUTO A. S. ©

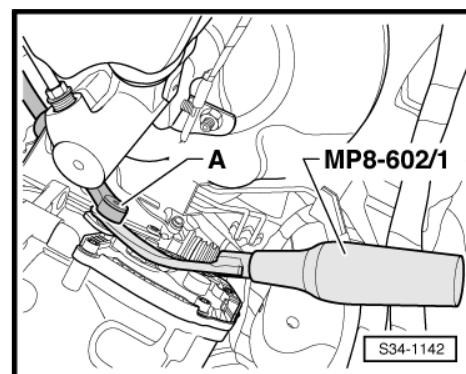



- Remove the lock washer -arrow- for the selector lever control cable, the selector lever control cable must be left in the fitting position.



Note

- ◆ *The lock washer -1- of the selector lever control cable must always be replaced ⇒ Electronic Catalogue of Original Parts .*
- ◆ *Do not bend or buckle selector lever control cable.*

- Raise vehicle.
- Remove the rear tunnel bridge -1- and the front tunnel bridge -2- from the body (if present).
- Detach the bracket -3- for the exhaust system from the assembly carrier.
- Release double clamp -4-.



Note

- ◆ *The decoupling element in the pre-exhaust pipe should not be bent by more than 10° - risk of damage.*
- ◆ *A second mechanic is needed to remove the rear part of the exhaust system.*

- Remove the exhaust tailpipe -5- from the double clamp ⇒ Engine ⇒ Rep. Gr. 26 .
- Slacken the trim panels for the underfloor on left -6- and right -7- from the body.
- Unclip lambda probe cable at heat shield.

- Remove the heat shield below the shift mechanism towards the rear, to do so slacken the clips -arrows-

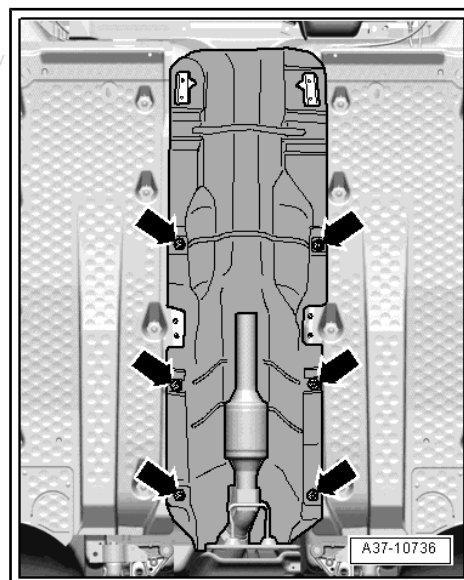
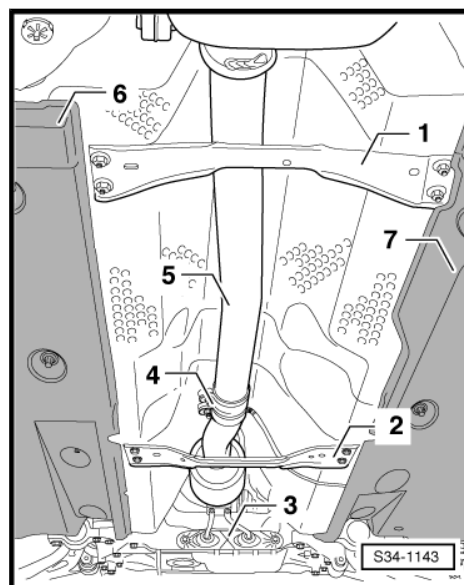
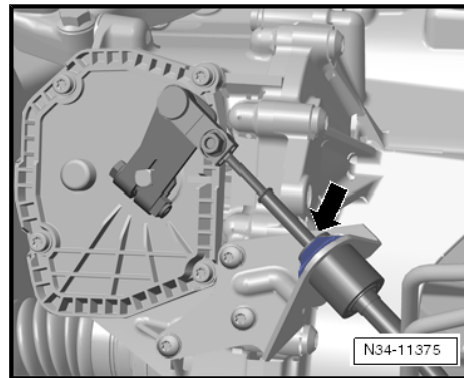

- Unscrew the nuts -1- and push the shift housing -2- onto the selector lever control cable as far as possible towards the front.

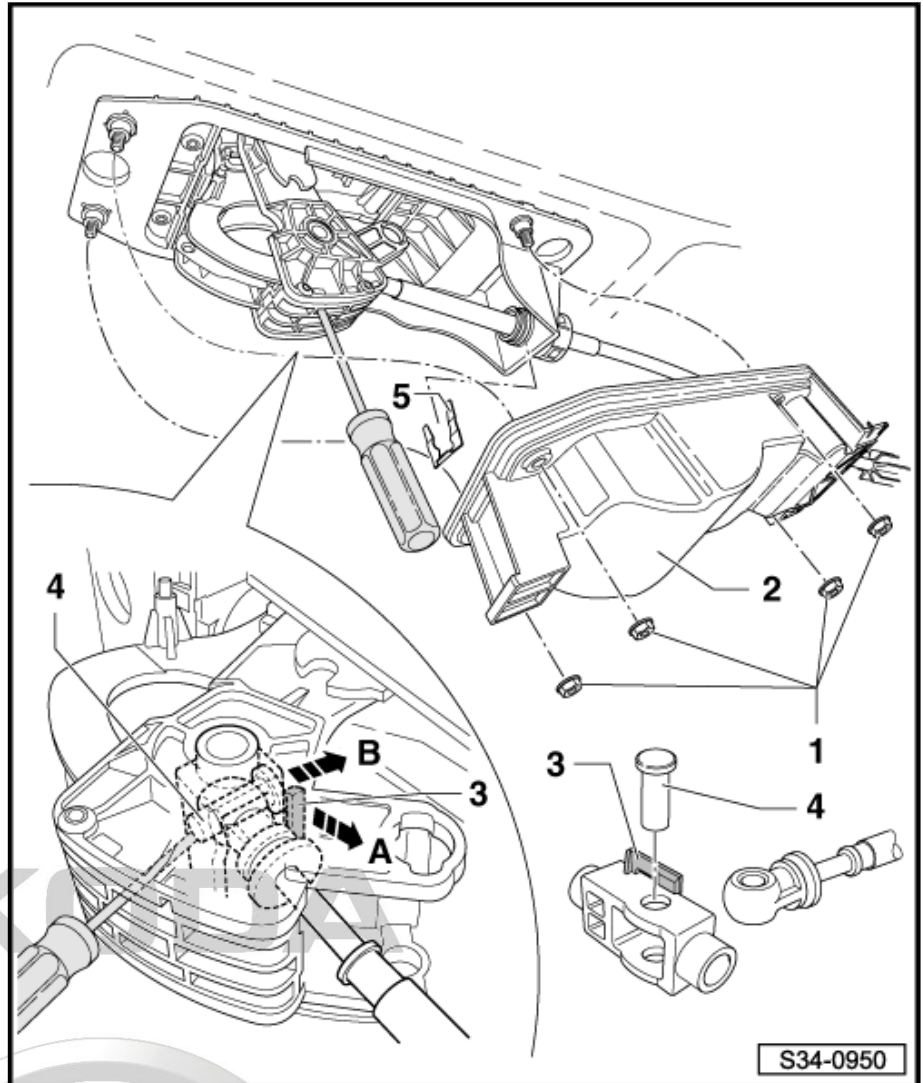

Caution

- Pull the locking tab -3-, which secures the bolt -4-, carefully in the -direction of arrow A-. At the same time, press the bolt -4- with a screwdriver only as far as necessary in -direction of arrow B-.



Note

- ◆ *Do not break off the locking tab -3-, otherwise the gearshift mechanism must be replaced.*
 - ◆ *Insert the screwdriver into the right bore hole of the gearshift mechanism and press it against the bolt as shown in the illustration.*
 - ◆ *This procedure is only possible if the selector lever is shifted into position "S".*
 - ◆ *Make sure that the pin is not fully pressed out. It is difficult to insert.*
- Remove lock washer -5-.



Vehicles as of production date 06.09 ("new shifting")



Note

The selector lever control cable (vehicles as of production date 06.09) ("new shifting" ⇒ [page 54](#)) must not be removed from the shift mechanism, it must be replaced as one component part ⇒ *Electronic Catalogue of Original Parts*.

- Remove the shift mechanism together with the selector lever control cable ⇒ [page 57](#).

Continued for vehicles up to production date 05.09 ("old shifting")

- Remove selector lever control cable.

2.8.2 Install

Installation is performed in the reverse order, pay attention to the following points:



Note

- ◆ *Inspect boot of selector lever control cable for damage; the boot can only be replaced together with the selector lever control cable.*
- ◆ *Check correct fitting of the boot and do not install the boot twisted.*

Tightening torques of screws or nuts as well as the instructions, if the screws or nuts have to be replaced ⇒ [page 52](#).

Do not grease ball socket of the selector lever control cable and ball head/selector lever.

Vehicles up to production date 05.09 ("old shifting")



Caution

- ◆ *Under no circumstances touch the circuit board of the gearshift mechanism with the fingers, because static discharge can destroy the electrical components and the circuit board.*
- ◆ *The circuit board can only be replaced together with the gearshift mechanism!*

- Insert the selector lever control cable with protective cover into the shift housing. At the same time do not damage the boot.
- Insert the end of the selector lever control cable -4- into the joint of the selector lever.
- Press bolt -3- downwards -direction of arrow- and check if the locking tab -2- is locked.
- Insert the lock washer -1- for the selector lever control cable.
- Fitting location: angled end towards the gearshift mechanism.

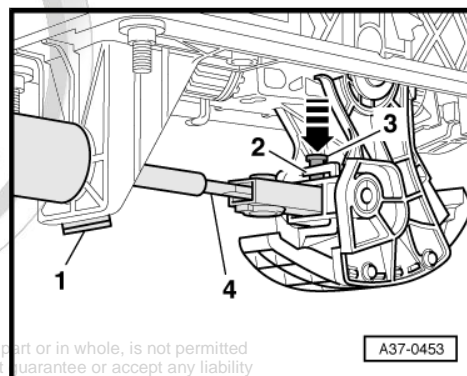

- Screw gearshift housing onto gearshift mechanism -arrows- and tighten to tightening torque ⇒ [page 52](#) .

Vehicles as of production date 06.09 (“new shifting”)



*The selector lever control cable (vehicles as of production date 06.09) (“new shifting” ⇒ [page 54](#)) must not be removed from the shift mechanism, it must be replaced as one component part ⇒ *Electronic Catalogue of Original Parts* .*

- Install the shift mechanism together with the selector lever control cable ⇒ [page 59](#)

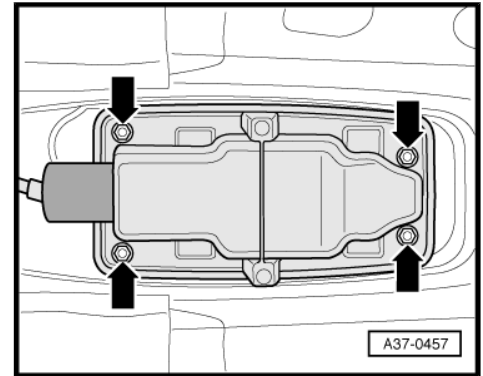

Continued for all vehicles

- Carefully press the selector lever control cable -2- onto the lever/gearshift shaft of the gearbox and secure in the cable support with a new lock washer -1-.
- Shift selector lever from “S” to “P”.
- Gearshift mechanism and selector lever control cable must move smoothly for this purpose.
- Then adjust the selector lever control cable ⇒ [page 49](#) .
- Inspect gearshift mechanism ⇒ [page 48](#) .
- Install air filter ⇒ Engine ⇒ Rep. Gr. 24 .
- Install the heat shield below the shift mechanism and fasten the trim panels for the underfloor on the body ⇒ Body Work ⇒ Rep. Gr. 50 .
- Install exhaust system and align free of stress ⇒ Engine ⇒ Rep. Gr. 26 .
- Install tunnel bridges below the exhaust system ⇒ Engine ⇒ Rep. Gr. 26 .

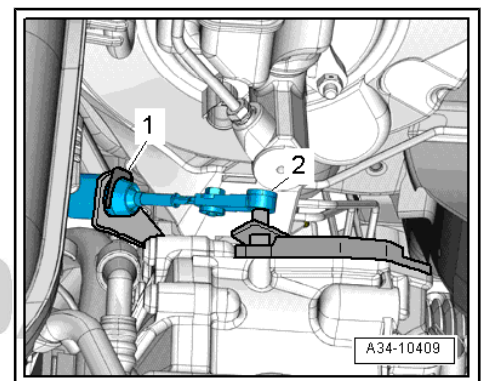

2.9 Emergency release of gearshift mechanism out of position “P”

Selector lever lock solenoid -N110- locks the selector lever in position “P”. The selector lever can only be moved out of “P” when ignition is on or starting the engine, the brake pedal is actuated and the button on the selector lever grip is pressed.

If there are faults in the voltage supply to the selector lever lock solenoid (battery discharged or fuse defective) or in case of defective solenoids, the selector lever cannot be moved out of the position “P”; i.e the vehicle cannot be moved because the parking position is engaged.

If this is the case:

- Test fuse ⇒ Current flow diagrams and Fitting locations.
- Check battery voltage ⇒ Electrical System ⇒ Rep. Gr. 27 .

If the selector lever cannot be moved out of position “P” despite the checks, the emergency release of the solenoids must be performed. If the selector lever is then shifted again into the position “P”, it is mechanically blocked again in the position “P”.

2.9.1 Perform emergency release

Special tools and workshop equipment required

Protected by copyright. Copying for private or commercial purposes, in part or in whole, is not permitted unless authorised by ŠKODA AUTO A. S. ŠKODA AUTO A. S. does not guarantee or accept any liability with respect to the correctness of information in this document. Copyright by ŠKODA AUTO A. S. ©



- ◆ Release tool -T30098-
- Open ashtray in the centre console.
- Release the front right cover -arrow- using the release tool -T30098-. Then release the rear right and centre cover -arrow-.

Carefully slacken the cover.

i Note

Do not remove grip of selector lever.

- Depress the brake pedal or pull on the handbrake.

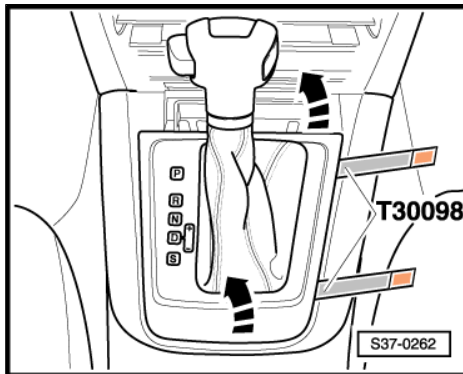

Vehicles up to production date 05.09 ("old shifting")

- Press from right to left -arrow- on the yellow plastic part.
- Now press the button on the selector lever grip and shift the selector lever in the direction out of the position "P".

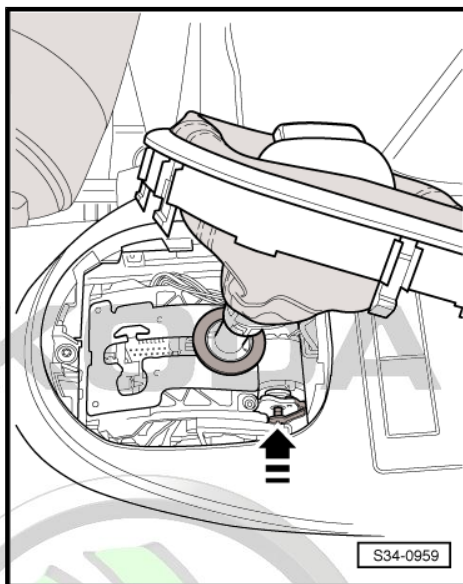

Vehicles as of production date 06.09 ("new shifting")

- Press the yellow plastic wedge -A- in -direction of arrow 1-.
- Now press the button on the selector lever grip and shift the selector lever -B- in -direction of arrow 2- out of the position "P".

Continued for all vehicles

i Note

If the selector lever is then shifted again into the position "P", it is mechanically blocked again in the position "P".

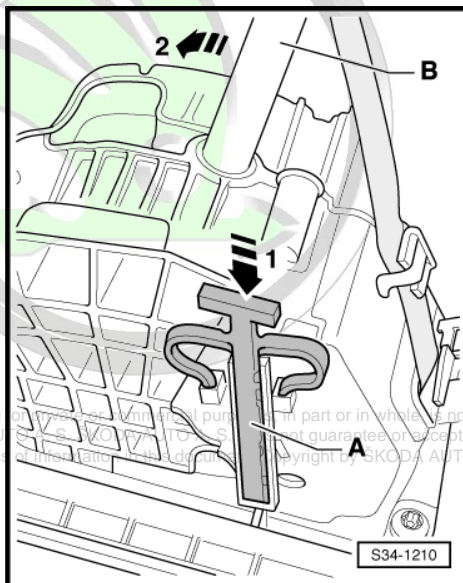

Protected by copyright. Copying or reproduction in any form or by any means, in part or in whole, is not permitted unless authorised by ŠKODA AUTO a.s. Všechny práva vyhrazena. ŠKODA AUTO a.s. nebera žádnou odpověď za případné chyby nebo nepřesnosti s ohledem na správnost informací.

2.10 Removing and installing the Tiptronic switch -F189-

The Tiptronic switch -F189- is integrated firmly in the gearshift mechanism and cannot be replaced separately. If the Tiptronic

switch -F189- is defective, the gearshift mechanism must be replaced ⇒ [page 57](#) .

2.11 Removing and installing selector lever lock solenoid -N110-

The selector lever lock solenoid -N110- is integrated firmly in the gearshift mechanism and cannot be replaced separately. If the selector lever lock solenoid -N110- is defective, the gearshift mechanism must be replaced ⇒ [page 57](#) .

2.12 Removing and installing selector lever switch locked in P -F319 -

The selector lever switch locked in P -F319- is integrated firmly in the gearshift mechanism and cannot be replaced separately. If the selector lever switch locked in P -F319 - is defective, the gearshift mechanism must be replaced ⇒ [page 57](#) .

2.13 Removing and installing the selector lever sensor control unit -J587-

Selector lever sensor control unit -J587- is integrated firmly in the gearshift mechanism and cannot be replaced separately. If the selector lever sensor control unit -J587- is defective, the gearshift mechanism must be replaced ⇒ [page 57](#) .

2.14 Checking the plug connections at the gearshift mechanism

Before repairing or checking the plug connections, try to determine the origin of the damage via the “targeted fault finding” using the ⇒ Vehicle diagnosis, testing and information system VAS 5051.

Before checking the plug connections, all control units in the vehicle should be checked with the ⇒ Vehicle diagnosis, testing and information system VAS 5051, if necessary the faults must be rectified.

- Check plug connections ⇒ Current flow diagrams and Fitting locations.

A - 10-pin plug for connection lines from the gearshift mechanism to the gearbox (with CAN databus lines)

B - 4-pin plug to selector lever lock solenoid -N110- , selector lever sensor control unit -J587- and selector lever switch locked in P -F319-

C - 10-pin plug to lamp for selector lever scale illumination -L101- in the cover for the shift mechanism

Protected by copyright. Copying for private or commercial purposes, in part or in whole, is not permitted unless authorised by ŠKODA AUTO A. S. ŠKODA AUTO A. S. does not guarantee or accept any liability with respect to the correctness of information in this document. Copyright by ŠKODA AUTO A. S. ©



As of production date 06.09 the shift mechanism is changed, the 4-pin plug connection -B- and the selector lever lock solenoid -N110- -1- are already located in the shift mechanism ⇒ [page 54](#) .

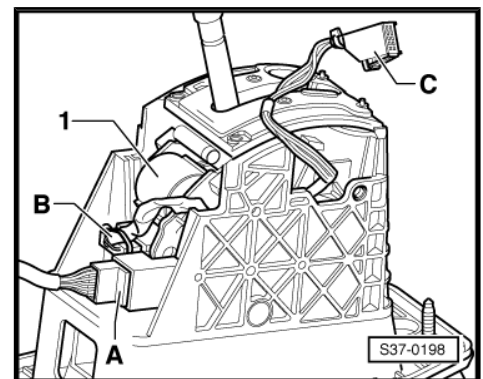



3 Mechatronics for double clutch gear- box -J743-

3.1 Safety instruction for^o mechatronics for double clutch gearbox -J743-



DANGER!

Do not remove the pressure tank. The pressure tank is under pressure and should not be opened.



Caution

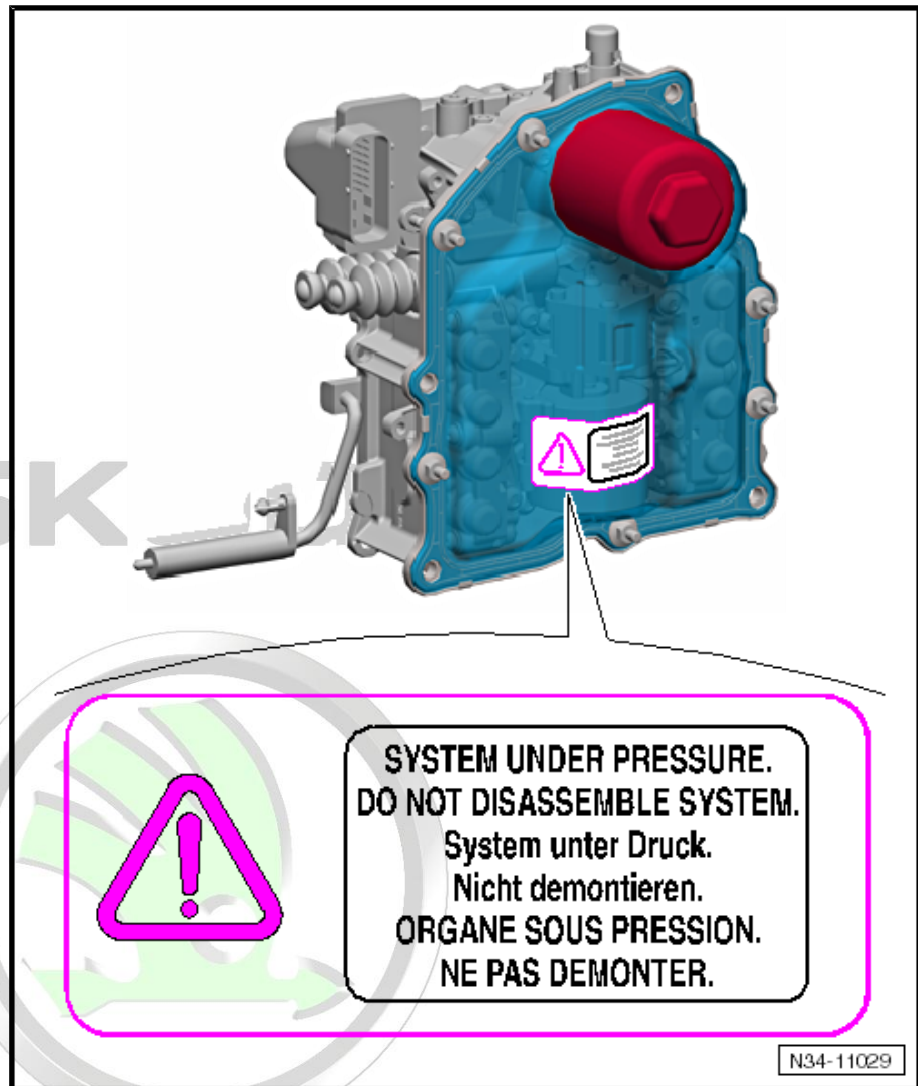

3.2 Summary of components - mechatronics for double clutch gearbox -J743-

Note

- ◆ The “new” mechatronics for the gearbox is already precisely filled with oil at the factory, do not drain the oil.
- ◆ The “removed” mechatronics is sent back with oil (close the ventilation opening with a suitable plug).
- ◆ Pay attention to the ventilation when handling the mechatronics .
- ◆ During assembly work, remove the cover of the ventilation and close with a suitable screw plug.

1 - Screw, 10 Nm

- 3 pieces, M8 x 35
- always replace ⇒ Electronic Catalogue of Original Parts
- for attaching the mechatronics for double clutch gearbox -J743- at gearbox housing

2 - Screw, 10 Nm

- 4 pieces, M8 x 90
- always replace ⇒ Electronic Catalogue of Original Parts
- for attaching the mechatronics for double clutch gearbox -J743- at gearbox housing

3 - Mechatronics for double clutch gearbox -J743-

- The mechatronics is allocated according to the gearbox code letters ⇒ Electronic Catalogue of Original Parts .
- Place the mechatronics by hand in the “removal position” ⇒ [page 79](#) .

Gearbox installed:

- Remove mechatronics ⇒ [page 73](#)
- Install mechatronics ⇒ [page 86](#)

Gearbox removed:

- Remove mechatronics ⇒ [page 69](#)
- Install mechatronics ⇒ [page 81](#)

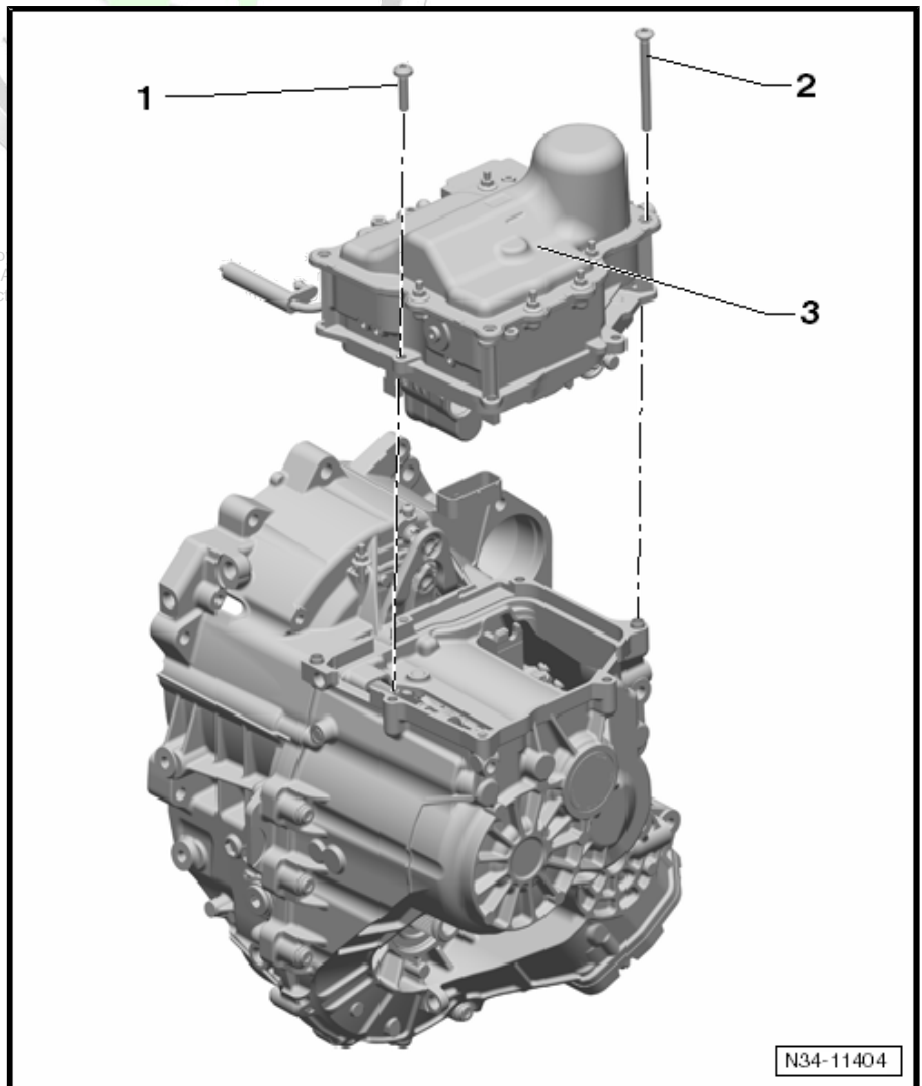

3.3 Removing mechatronics for double clutch gearbox -J743 - ; gearbox removed.

Special tools and workshop equipment required

- ◆ Assembly lever -T10407-



Note

- ◆ *The clutch is self-adjustable. Vibrations can have a negative effect on the adjusting device. Also when the mechatronics is removed, the "sudden removal" of the drifts below the engaging levers can have a negative effect on the adjusting device.*
 - ◆ *Observe safety instruction for the mechatronics for double clutch gearbox -J743- ⇒ [page 68](#) .*
 - ◆ *Turn the removed gearbox in such a way that the mechatronics for double clutch gearbox -J743- points to the top, if necessary drain gear oil.*
 - ◆ *The mechatronics is allocated according to the gearbox code letters ⇒ *Electronic Catalogue of Original Parts* .*
 - ◆ *The "new" mechatronics for the gearbox is already precisely filled with oil at the factory, do not drain the oil.*
 - ◆ *The "removed" mechatronics is sent back with oil (close the ventilation opening with a suitable plug).*
- Remove the cover from the ventilation and close with a suitable screw plug so that no oil can flow out.

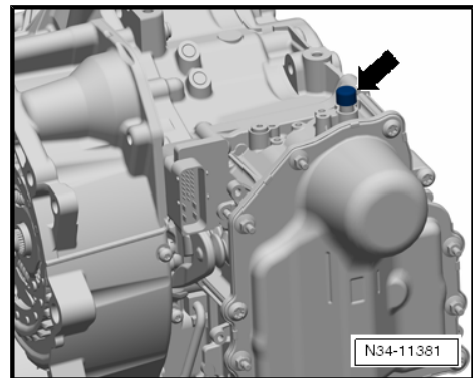

- Carefully unlock the gearbox input r.p.m sender -G182- with a screwdriver and pull it out of the housing in the -direction of arrow-.

Now both levers of the clutch control must be pressed off the mechatronics with the assembly lever -T10407- . Otherwise the lever for mechatronics strikes the tappets and the mechatronics cannot be removed.

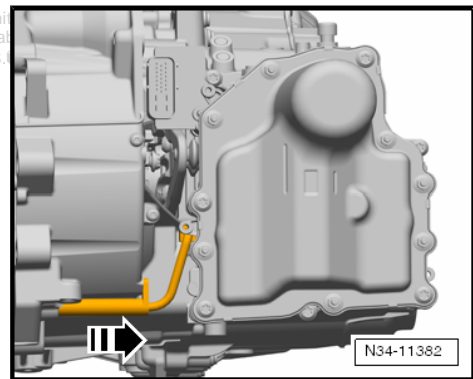

- Insert the assembly lever -T10407- as a safety between both clutch control levers and gearbox housing.

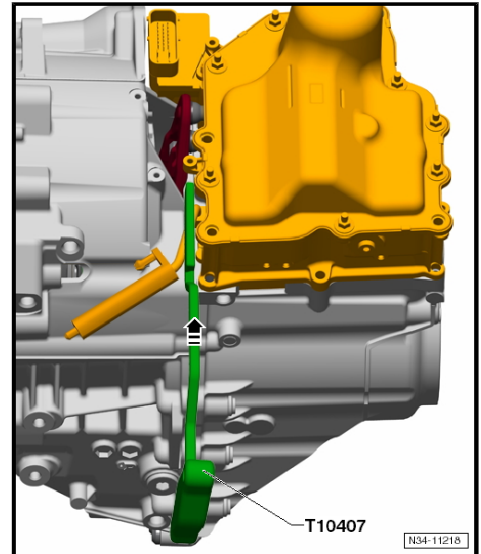

The assembly lever -T10407 - should rest with the complete surface of the "reverse side" against the gearbox housing and the nut should form one level with the recess of the housing.

 **Note**

The recess of the housing and the nut on the lever must form one level. Do not insert the assembly lever -T10407- up to the stop.

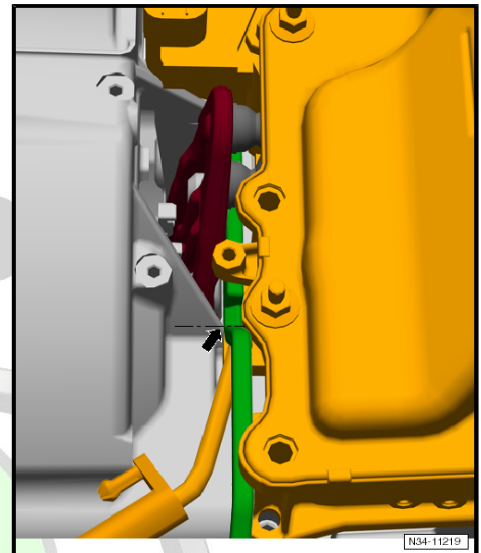

- Turn the assembly lever -T10407- to the left in -direction of arrow- and thus press the engaging lever away from the tappets.

 **Note**

Do not remove the assembly lever -T10407 - .

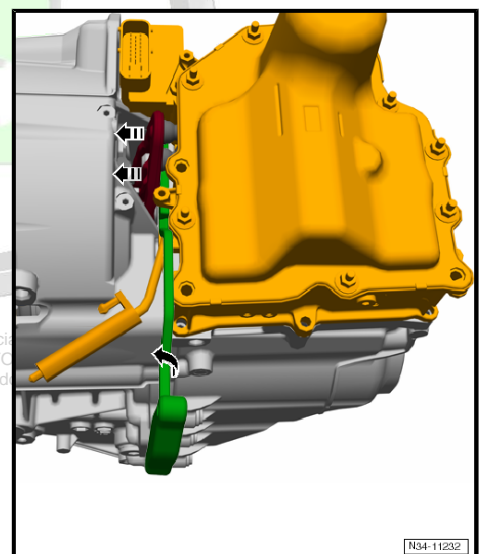

Protected by copyright. Copying for private or commercial use is prohibited without the written permission of ŠKODA AUTO A. S. ŠKODA AUTO A. S. reserves the right to change the technical specifications without notice. The manufacturer is not responsible for the correctness of information in this document.



If necessary, press the assembly lever -T10407- against the gear-box using a screwdriver, thereby both levers of the clutch control are pressed off the mechatronics .



Note

While doing so, the rubber grommets of the clutch actuators should not be damaged.

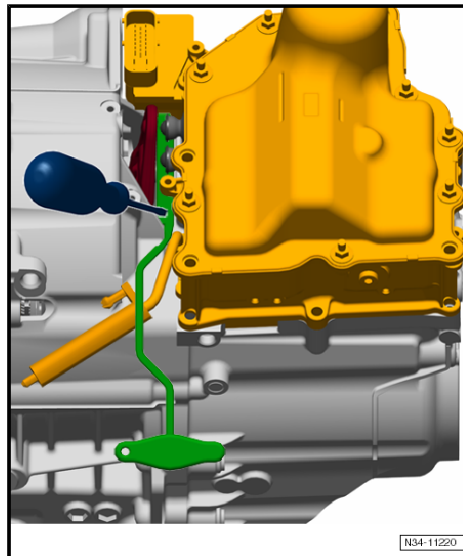

- Unscrew the screws -A- (3 pieces, M8 x 35) and -B- (4 pieces, M8 x 90) crosswise.



Note

- ◆ Do not remove more than 7 screws! "There are 4 long and 3 short screws".
 - ◆ Do not slacken the cover screws of the mechatronics .
 - ◆ Place down the removed mechatronics in such a way that no oil can flow out of the ventilation. The mechatronics including the oil is passed on for recycling.
 - ◆ Drained oil must not be refilled.
- Grab with the hand (without gloves) at the mass, in order to discharge yourself electrostatically.

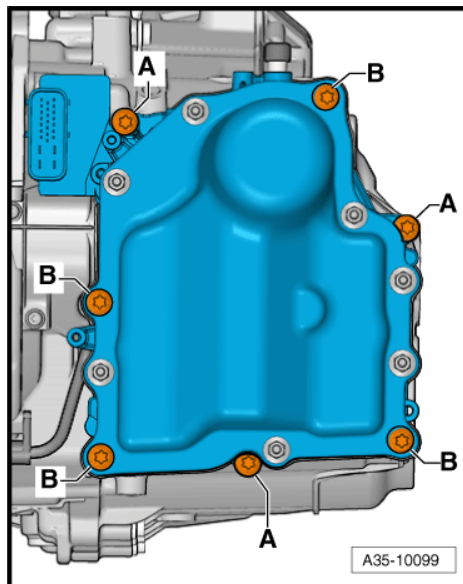

Caution

- ◆ Only then touch or remove the mechatronics for double clutch gearbox -J743- , after you have discharged yourself electrostatically at an earthed object beforehand, e.g. skin contact with mass.
- ◆ Under no circumstances must the plug contacts in the plug of the gearbox be touched with the hands, because the control unit can be destroyed through static discharge as well as the mechatronics.

- Remove mechatronics.

If the mechatronics "clamps":

It is possible that the mechatronics cannot be removed. In this case, the gear actuator "jams" at the "top left" on the gearbox housing.

In this case, the mechatronics should not be removed with increased force.

- In this case, the mechatronics must be put back into the "removal position" by hand ⇒ [page 79](#) .

Install mechatronics on removed gearbox ⇒ [page 81](#) .

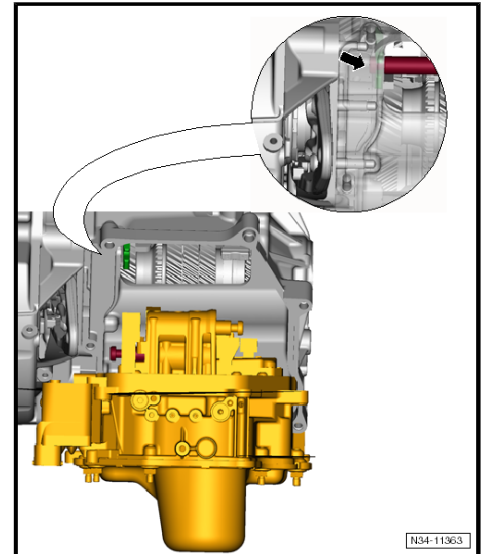

3.4 Remove mechatronics for double clutch gearbox -J743- ; gearbox installed.

Special tools and workshop equipment required

- ◆ Assembly lever -T10407 -
- ◆ Vehicle Diagnosis, Measurement and Information System - VAS-
- ◆ Oil pan -VAS 6208-



Note

- ◆ *Observe safety instruction for the mechatronics for double clutch gearbox -J743- ⇒ [page 68](#) .*
- ◆ *Observe instructions for automatic gearbox DSG - 0AM ⇒ [page 4](#) .*
- ◆ *General repair information ⇒ [page 4](#) .*
- ◆ *The clutch is self-adjustable. Vibrations can have a negative effect on the adjusting device. Also when the mechatronics is removed, the "sudden removal" of the drifts below the engaging levers can have a negative effect on the adjusting device.*
- ◆ *Ensure adequate clearance in front of the gearbox in order to remove the mechatronics. Components, which are not directly connected with the gearbox, must be removed on some vehicles. The existing brackets, if applicable, must be removed at the screws of the cover for mechatronics.*
- ◆ *If the battery earth strap is disconnected and connected, carry out certain additional operations ⇒ Electrical System ⇒ Rep. Gr. 27 .*

The mechatronics remains filled with oil

- Shift selector lever into position "P".

Before the actual removal of the mechatronics , carry out the basic setting of the "idle position " of the gearbox with the ⇒ Vehicle diagnosis, testing and information system VAS 5051.

- Select Targeted functions and subsequently select the basic setting of the idle position.



- Disconnect the battery-earth strap with the ignition off ⇒ Electrical System ⇒ Rep. Gr. 27 .
- Remove air filter ⇒ Engine ⇒ Rep. Gr. 24 .
- Remove battery and battery tray ⇒ Electrical System ⇒ Rep. Gr. 27 .
- Disconnect the connector catch on the mechatronics by pulling in -direction of arrow- and release the plug.

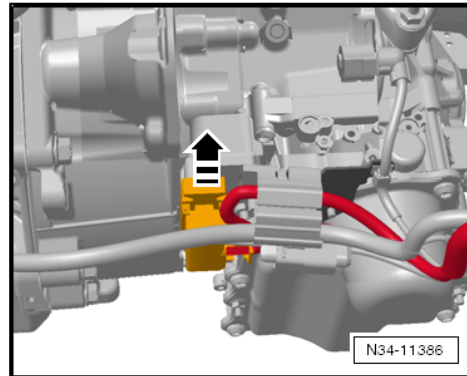

- Remove the cover from the ventilation and close with a suitable screw plug so that no oil can flow out.

 **WARNING**

Hot steam may escape after the compensation bottle is opened. Cover the cap with a cloth and open carefully.

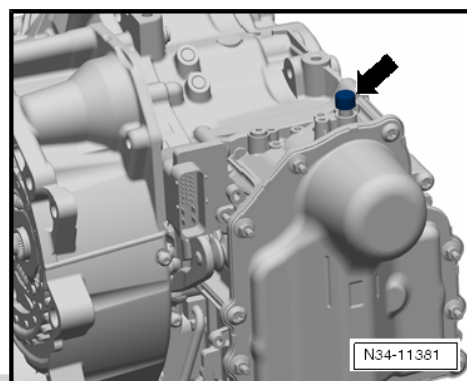

- When the engine is warm the cooling system is under pressure. Slowly open the cap of the compensation bottle, in order to first reduce pressure before pulling off the coolant hoses.
- Remove bottom noise insulation ⇒ Body Work ⇒ Rep. Gr. 50 .
- Remove the charge air hose from the bottom left charge air cooler and the charge air pipe ⇒ Engine ⇒ Rep. Gr. 21 .

 **Note**

Shut off the opening of the charge air cooler so that no coolant can penetrate.

- Disconnect plug -2- at the coolant temperature sender at radiator outlet -G83- .
- Place an oil pan -VAS 6208- under the radiator.
- Remove the bottom coolant hose -1- from the radiator, to do so raise the retaining clip ⇒ Engine ⇒ Rep. Gr. 19 .

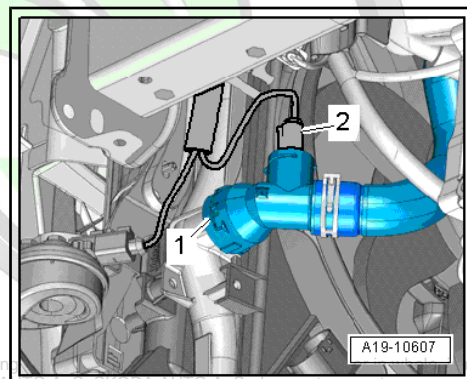

Protected by copyright. Copying or reproduction in any form is not permitted unless authorised by ŠKODA AUTO A.S. ŠKODA AUTO A.S. assumes no liability with respect to the correctness of information in this document. Copyright by ŠKODA AUTO A. S. ©

- Separate the electrical plug connections -1- for the bottom radiator fan at the fan shroud.
- Screw out screws -arrows- and remove fan shroud with radiator fans downwards.
- Remove the electrical lines from the front holder at the mechatronics and tie up to the top.
- Remove the holder from the mechatronics .
- Position the catch pan under the gearbox.

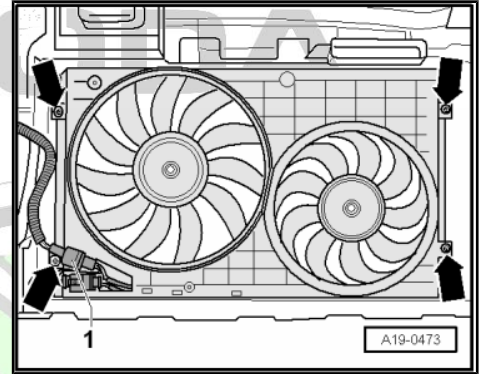

- Release oil drain plug -arrow- at the gearbox.

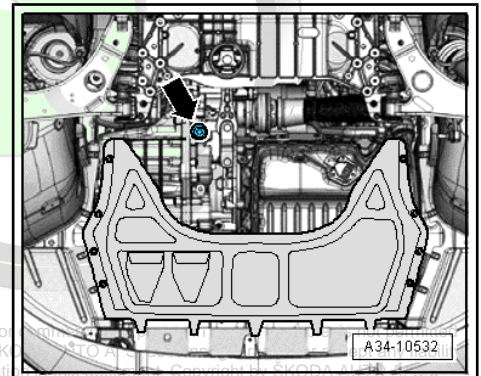

Protected by copyright. Copying for private or personal use, or for internal or limited distribution, is permitted by SKODA AUTO A. S. SKODA AUTO A. S. reserves the right to make changes to the technical specifications and drawings without notice. The information is provided for informational purposes only. It is not intended to be used as a substitute for the correct information.

- Drain off oil.
- Install oil drain plug.

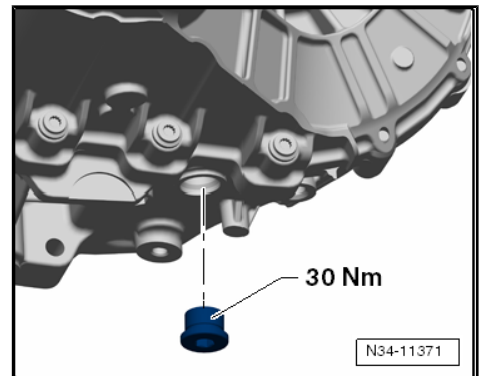

- Remove all the front brackets from the gearbox.

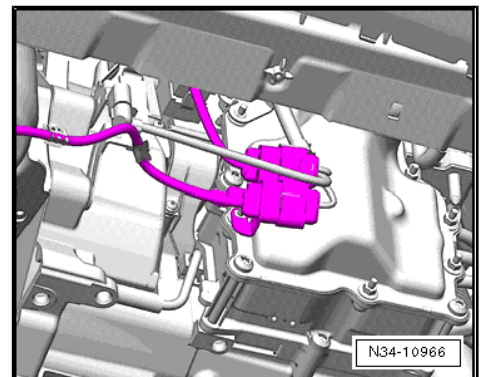



- Carefully unlock the gearbox input r.p.m. sender -G182 - with a screwdriver and pull it out of the housing in the -direction of arrow-.

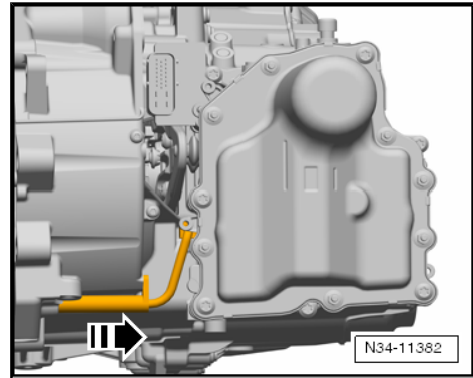

Now both levers of the clutch control must be pressed off the mechatronics with the assembly lever -T10407- . Otherwise the lever for mechatronics strikes the tappets and the mechatronics cannot be removed.

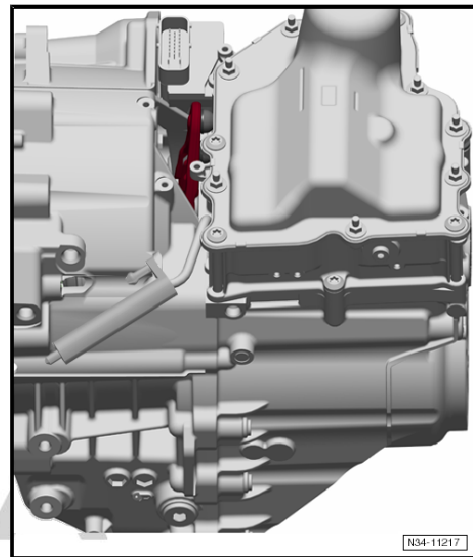

- Insert the assembly lever -T10407- as a safety between both clutch control levers and gearbox housing.

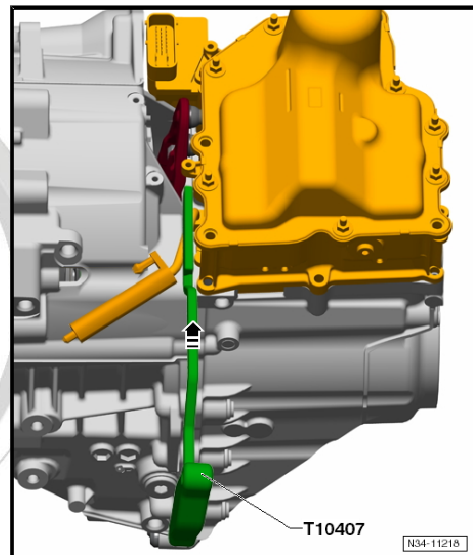

Protected by copyright. Copying for private or commercial purposes, in part or in whole, is not permitted unless authorised by ŠKODA AUTO A. S. ŠKODA AUTO A. S. does not guarantee or accept any liability with respect to the correctness of information in this document. Copyright by ŠKODA AUTO A. S. ©

The assembly lever -T10407 - should rest with the complete surface of the "reverse side" against the gearbox housing and the nut should form one level with the recess of the housing.

 **Note**

The recess of the housing and the nut on the lever must form one level. Do not insert the assembly lever -T10407- up to the stop.

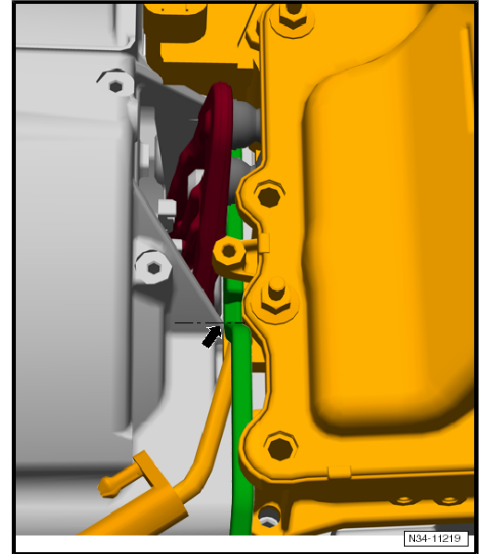

- Turn the assembly lever -T10407- to the left in -direction of arrow- and thus press the engaging lever away from the tappets.

 **Note**

Do not remove the assembly lever -T10407- .

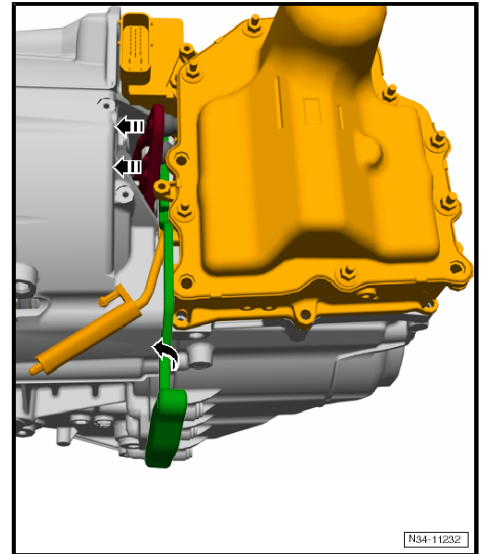

ŠKODA

If necessary, press the assembly lever -T10407- against the gear-box using a screwdriver, thereby both levers of the clutch control are pressed off the mechatronics .

 **Note**

While doing so, the rubber grommets of the clutch actuators should not be damaged.

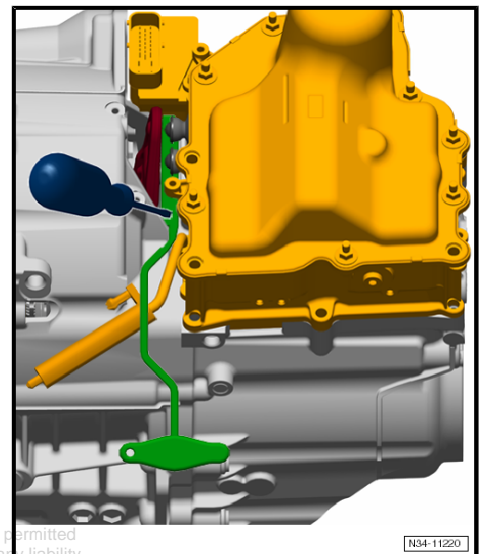
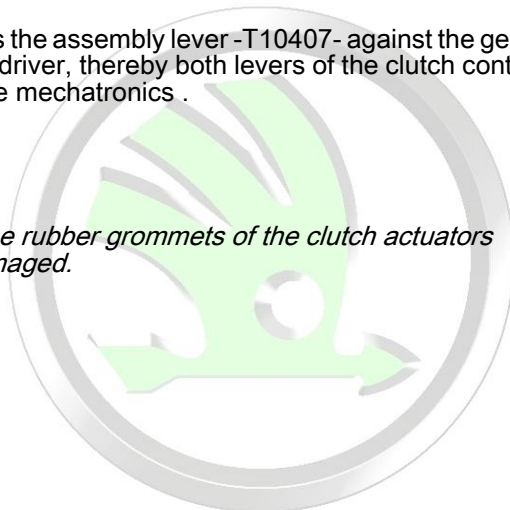



- Release long screws -B- (4 pieces, M8 x 90) crosswise.

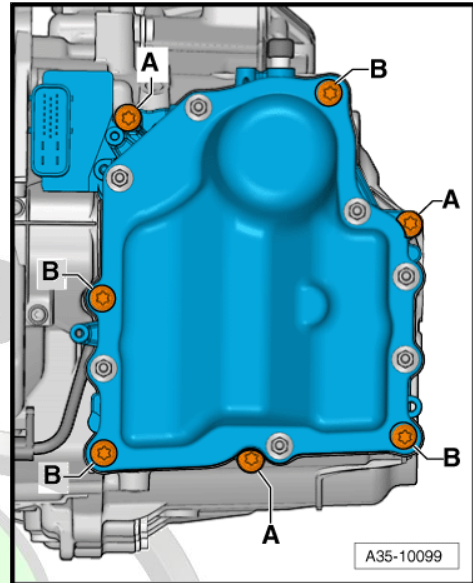

- Release the remaining screws -A- (3 pieces, M8 x 35) crosswise.



Note

- ◆ Do not remove more than 7 screws! "There are 4 long and 3 short screws".
 - ◆ Do not slacken the cover screws of the mechatronics .
 - ◆ Place down the removed mechatronics in such a way that no oil can flow out of the ventilation.
 - ◆ Drained oil must not be refilled.
- Grab with the hand (without gloves) at the mass, in order to discharge yourself electrostatically.

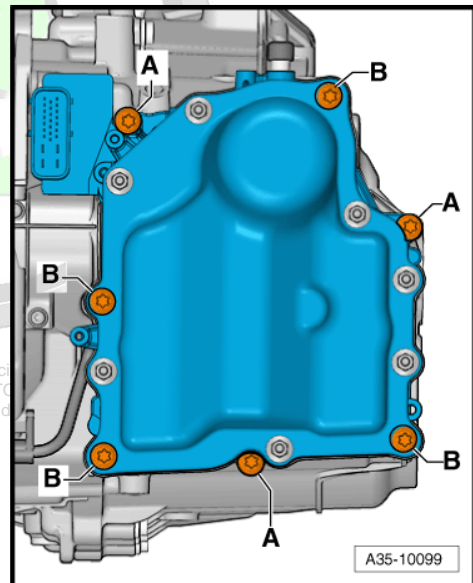

Caution

- ◆ Only then touch or remove the mechatronics for double clutch gearbox - J743- , after you have discharged yourself electrostatically at an earthed object beforehand, e.g. skin contact with mass.
- ◆ Under no circumstances must the plug contacts in the plug of the gearbox be touched with the hands, because the control unit can be destroyed through static discharge as well as the mechatronics.

- Remove mechatronics.

If the mechatronics “clamps”:

It is possible that the mechatronics cannot be removed. In this case, the gear actuator “jams” at the “top left” on the gearbox housing.

In this case, the mechatronics should not be removed with increased force.

- In this case, the mechatronics must be put back into the “removal position” by hand ⇒ [page 79](#) .

Install mechatronics on installed gearbox ⇒ [page 86](#) .

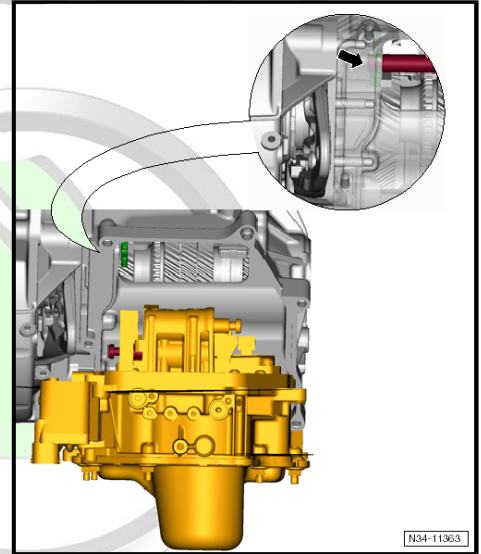

3.5 Place the mechatronics for double clutch gearbox -J743- by hand in the “removal position”

Protected by copyright. Copying for private or commercial purposes, in part or in whole, is not permitted unless authorised by ŠKODA AUTO A. S. ŠKODA AUTO A. S. does not guarantee or accept any liability with respect to the correctness of information in this document. Copyright by ŠKODA AUTO A. S.

It is possible that the mechatronics cannot be removed. In this case, the gear actuator “jams” at the “top left” on the gearbox housing -arrow-.

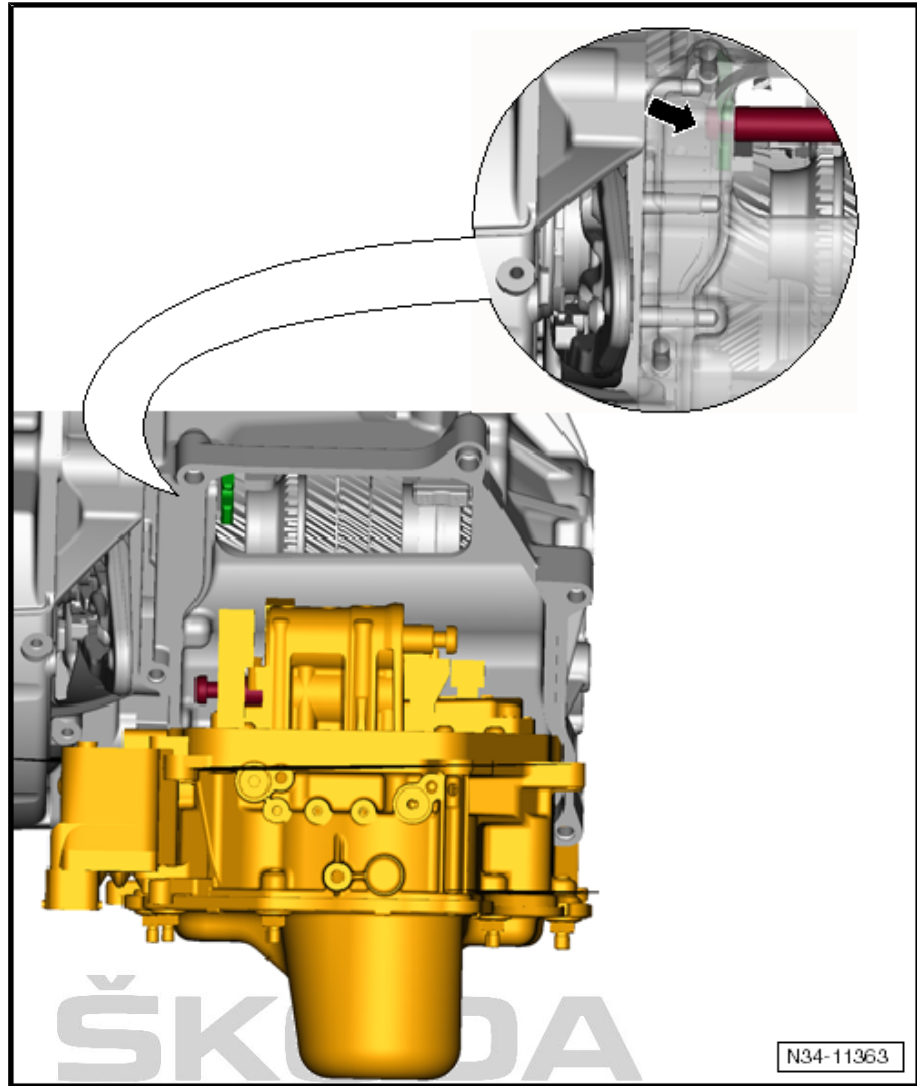

N34-11363

The “jammed” gear actuator must now be pressed by hand into the “removal position”. To do so, remove the cover on the gear-shift shaft.

Gearbox installed:

The mechatronics is located in the gearbox housing and is secured with a screw.

- Shift selector lever into position “P”.
- Remove battery and battery tray ➔ Electrical System ➔ Rep. Gr. 27 (if they were not yet removed).
- Expose the selector lever control cable -A- from the gearbox shift lever with the removal tool for the inner lining of the door panel -MP8-602/1- (if it was not yet removed).

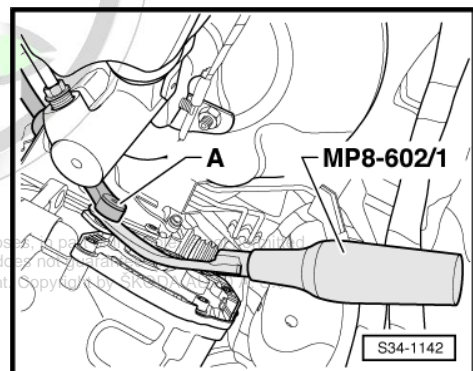

S34-1142

Protected by copyright. Copying for private or commercial purposes is prohibited without the prior written permission of ŠKODA AUTO A. S. ŠKODA AUTO A. S. does not accept any responsibility with respect to the correctness of information in this document. Copyright © ŠKODA AUTO A. S.

- Remove the lock washer -arrow- for the selector lever control cable, the selector lever control cable must be left in the fitting position.

i Note

- ◆ The lock washer -1- of the selector lever control cable must always be replaced ⇒ *Electronic Catalogue of Original Parts*.
- ◆ Do not bend or buckle selector lever control cable.

Gearbox removed:

- Position gearshift lever in "P".
- To do so, press the lever by hand up to the stop in the direction towards the cable support -arrow-.

The gearbox is installed or removed.

- Press the lever by hand up to the stop in the direction towards the cable support.

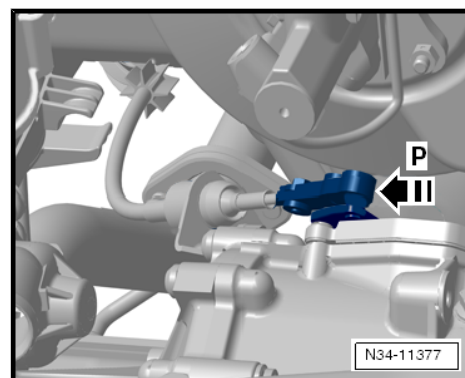
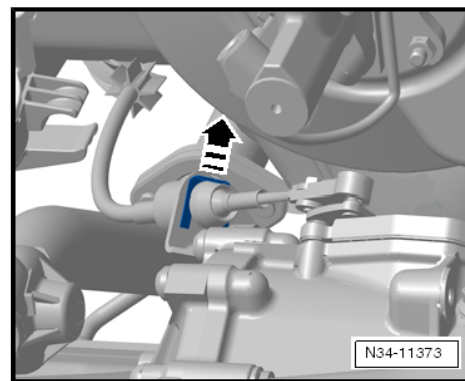

- Remove gearshift lever.
- Unscrew the cover.

i Note

The mechatronics will "no longer clamp" at the next work step. This means, it will malfunction under certain circumstances. If not yet performed, the mechatronics must be secured at the gearbox with a screw against falling down.

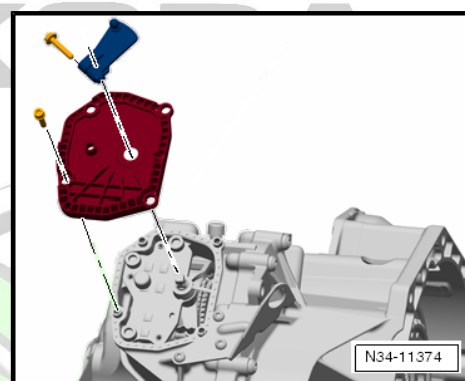

- Press the shift fork to the side through the opening in -direction of arrow-.

By doing so, the "jammed" gear actuator is now pressed back and the mechatronics can be removed.

i Note

Do not reinstall the cover yet, as the gear oil is filled up via this opening after installing the mechatronics for double clutch gearbox -J743- ⇒ [page 106](#).

Protected by copyright. Copying for private use is permitted without the need for permission, unless authorised by ŠKODA AUTO A. S. with respect to the correctness of information.

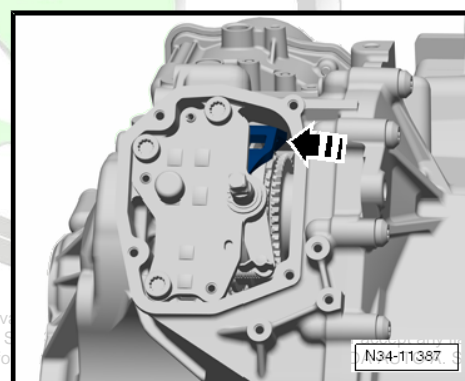

3.6 Installing mechatronics for double clutch gearbox -J743 - ; gearbox removed.

Special tools and workshop equipment required

- ◆ Assembly lever -T10407 -
- ◆ Guide bolt -T10406-



The mechatronics remains filled with oil

- If this is not yet the case: Close the ventilation with a suitable screw plug so that no oil can flow out.

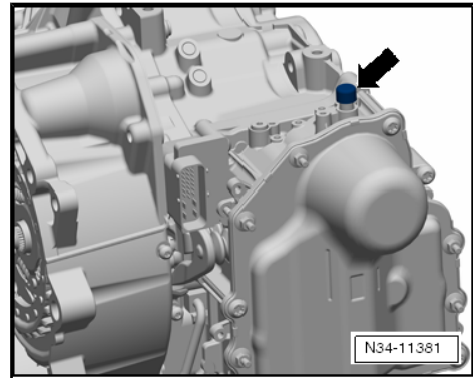

Note

- ◆ *Make sure that all the shift forks are in the "centre position" before installing the mechatronics for double clutch gearbox -J743- .*
- ◆ *The "centre position" is shown in the fig. as position -N- (neutral).*
- ◆ *No gear is engaged in this position, i.e neutral (neutral position) is engaged.*

- First check all 4 shift forks by hand.

All shift forks have 3 positions:

- Consecutively bring all 4 shift forks once into each position -arrows-.
- Then bring all the shift forks again into the "centre position", position -N-.

ŠKODA

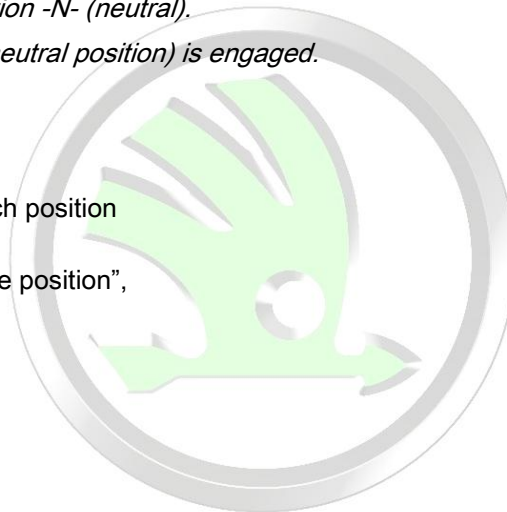

Protected by copyright. Copying for private or commercial purposes, in part or in whole, is not permitted unless authorised by ŠKODA AUTO A. S. ŠKODA AUTO A. S. does not guarantee or accept any liability with respect to the correctness of information in this document. Copyright by ŠKODA AUTO A. S. ©

N - Neutral/idling
R - Reverse gear



Note

- ◆ When the reverse gear is engaged, the extended tap mechatronics is hooked into the gearbox housing.
- ◆ Therefore, the mechatronics must be put into the position by hand ⇒ page 83

- 1 - first gear
- 2 - second gear
- 3 - third gear
- 4 - fourth gear
- 5 - fifth gear
- 6 - sixth gear
- 7 - seventh gear

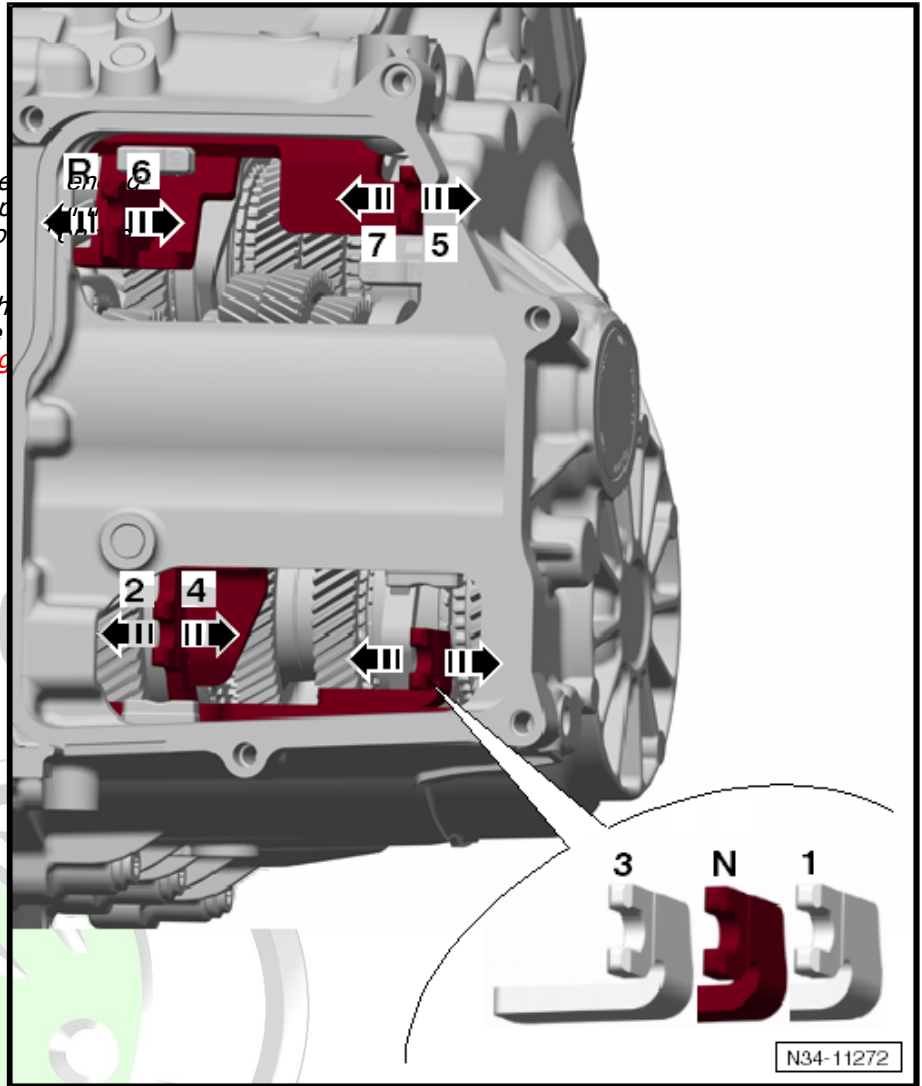

– Screw guide bolts -T10406- tightly by hand.

Protected by copyright. Copying for private or commercial purposes, in part or in whole, is not permitted unless authorised by ŠKODA AUTO A. S. ŠKODA AUTO A. S. does not guarantee or accept any liability with respect to the correctness of information in this document. Copyright by ŠKODA AUTO A. S. ©

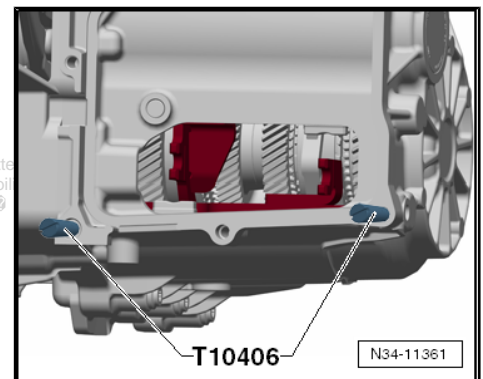

Adjust gear actuator:



Caution

Risk of damage mechatronics for double clutch gearbox - J743-.

When removing the pins, do not press the senders.

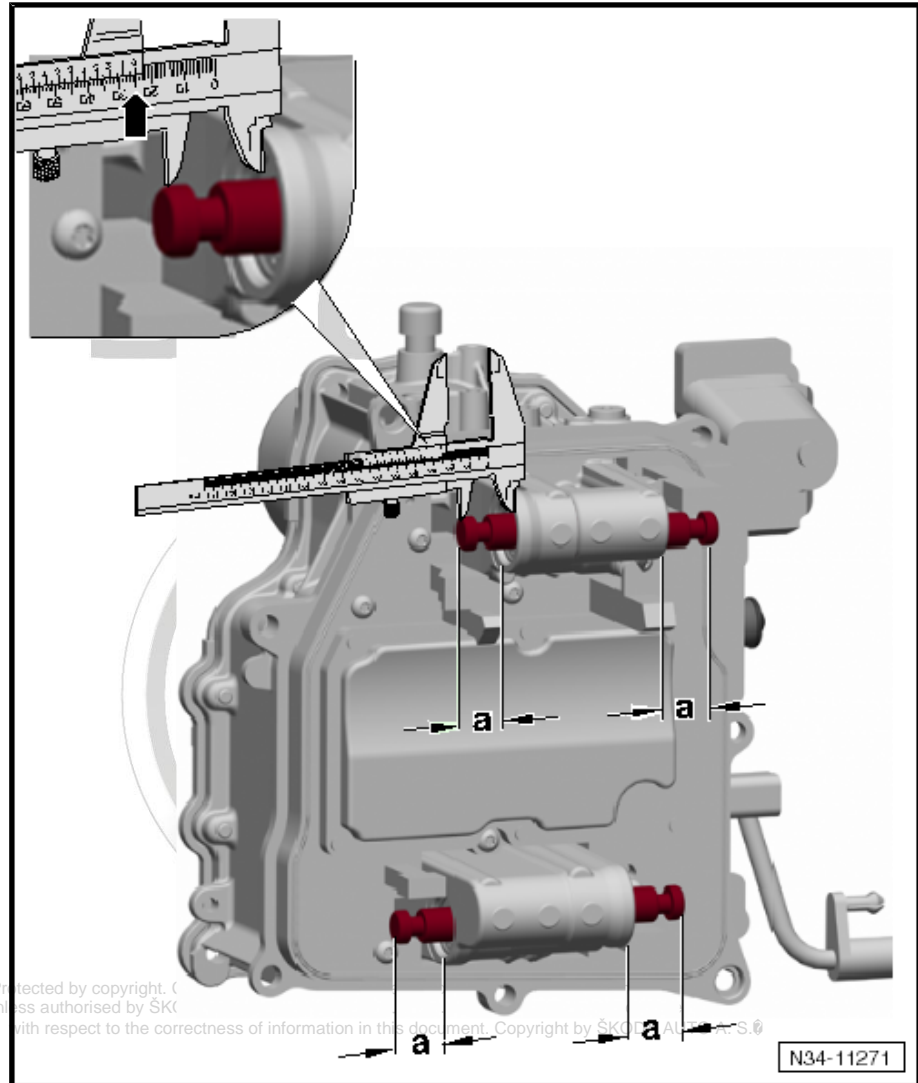

- Set the 4 gear actuators on the rear side of the mechatronics for double clutch gearbox -J743- into the specified position.

Specified position: -a- = 25 mm



Note

The seal for mechatronics for double clutch gearbox -J743- must be attached all around.

- Check the sender. The clip must not be damaged.
- Install mechatronics.

When handling and installing, make sure that the shift forks are not unintentionally pressed out of their position. Also pay attention to the engaging lever and the tappet of the mechatronics.

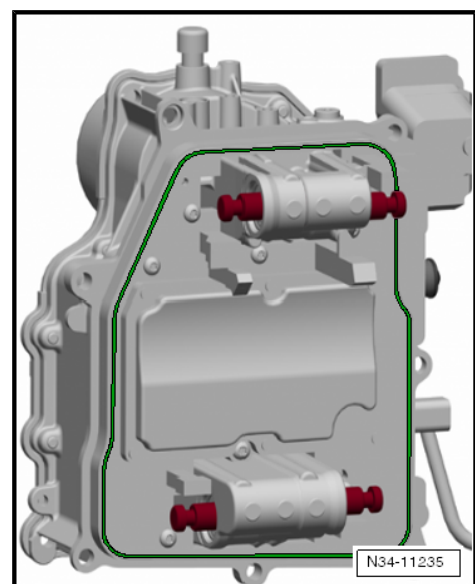



- Screw in the screws -A- (3 pieces, M8 x 35) and -B- (2 pieces, M8 x 90) crosswise by hand.
- Remove guide bolts -T10406- .
- Screw in the remaining screws -B- (2 pieces, M8 x 90) by hand.

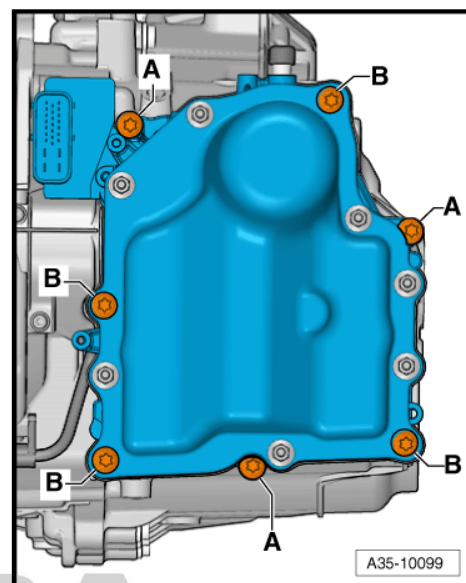

Make sure that the tappets fall precisely into the engaging lever bearing. Pull out the tappets by hand until they fit in these bearings.

- Now check the position of the tappets once again.



Note

Incorrectly mounted tappets will damage the mechatronics.

Protected by copyright. Copying for private or commercial purposes, unless authorised by ŠKODA AUTO A. S. ŠKODA AUTO A. S. does not accept any liability with respect to the correctness of information in this document. Copying is prohibited.



- Tighten all the screws for the mechatronics for double clutch gearbox -J743- crosswise to the recommended tightening torque => [page 69](#) .
- Turn the assembly lever -T10407 - "slowly and carefully" to the right and remove it.
- Both clutch adjusters must correctly lock in the recesses of the engaging levers for the clutch.
- While doing so, the rubber grommets of the clutch actuators should not be damaged.
- The rubber grommets must rest on the mechatronics.
- An incorrect assembly or damage to the rubber grommets leads to oil leakage in the mechatronics.

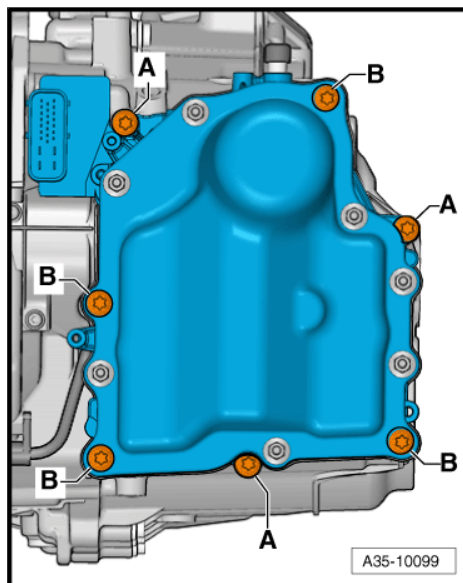

- Position the gearbox input r.p.m. sender -G182- in the -direction of arrow- on the gearbox housing.



Note

The sender must be completely and firmly positioned with the belt buckle tongue on the gearbox housing. If the switch is "loose", replace the mechatronics.

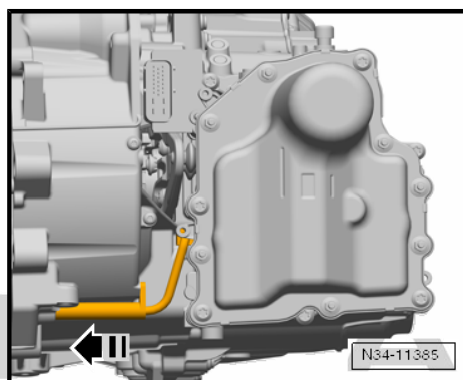

- Remove the screw plug from the ventilation and position the ventilation cap.

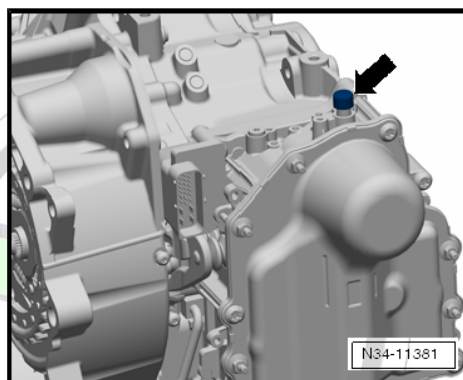

3.7 Install mechatronics for double clutch gearbox -J743 - ; gearbox installed

Special tools and workshop equipment required

- ◆ Assembly lever -T10407 -
- ◆ Guide bolt -T10406-
- ◆ Oil pan -VAS 6208-

Protected by copyright. Copying for private or commercial purposes, in part or in whole, is not permitted unless authorised by ŠKODA AUTO A. S. ŠKODA AUTO A. S. does not guarantee or accept any liability with respect to the correctness of information in this document. Copyright by ŠKODA AUTO A. S.

- If this is not yet the case: Close the ventilation with a suitable screw plug so that no oil can flow out.

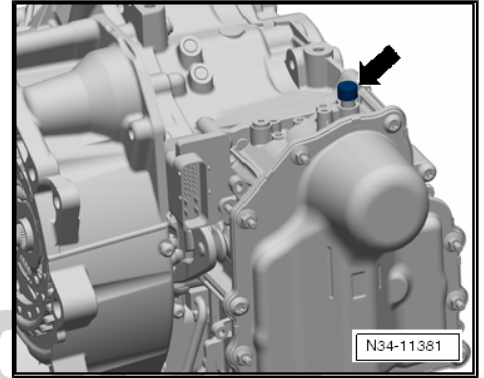

 Note

- ◆ *Make sure that all the shift forks are in the “centre position” before installing the mechatronics for double clutch gearbox -J743- .*
 - ◆ *The “centre position” is shown in the fig. as position -N- (neutral).*
 - ◆ *No gear is engaged in this position, i.e neutral (neutral position) is engaged.*
- First check all 4 shift forks by hand.
- All shift forks have 3 positions:
- Consecutively bring all 4 shift forks once into each position -arrows-.
 - Then bring all the shift forks again into the “centre position”, position -N-.

Protected by copyright. Copying for private or commercial purposes, in part or in whole, is not permitted unless authorised by ŠKODA AUTO A. S. ŠKODA AUTO A. S. does not guarantee or accept any liability with respect to the correctness of information in this document. Copyright by ŠKODA AUTO A. S. ©



N - Neutral/idling
R - Reverse gear



Note

- ◆ When the reverse gear is engaged, the extended tap mechatronics is hooked into the gearbox housing.
- ◆ Therefore, the mechatronics must be put into the position by hand => page 88

- 1 - first gear
- 2 - second gear
- 3 - third gear
- 4 - fourth gear
- 5 - fifth gear
- 6 - sixth gear
- 7 - seventh gear

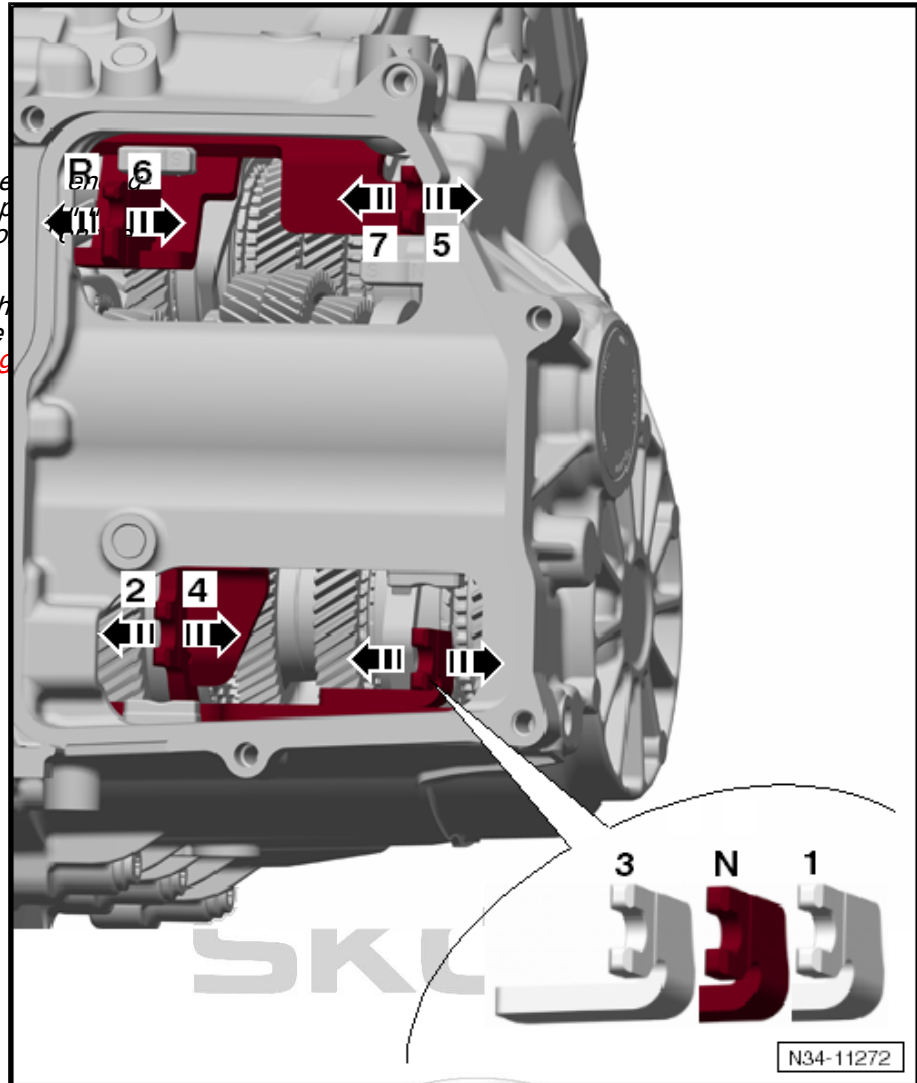

– Screw guide bolts -T10406- tightly by hand.

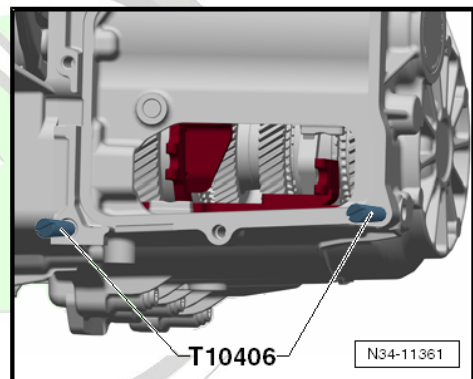

Adjust gear actuator:



Caution

Risk of damage mechatronics for double clutch gearbox - J743-.

When removing the pins, do not press the senders.

Protected by copyright. Copying for private or commercial purposes, in part or in whole, is not permitted unless authorised by ŠKODA AUTO A. S. ŠKODA AUTO A. S. does not guarantee or accept any liability with respect to the correctness of information in this document. Copyright by ŠKODA AUTO A. S.

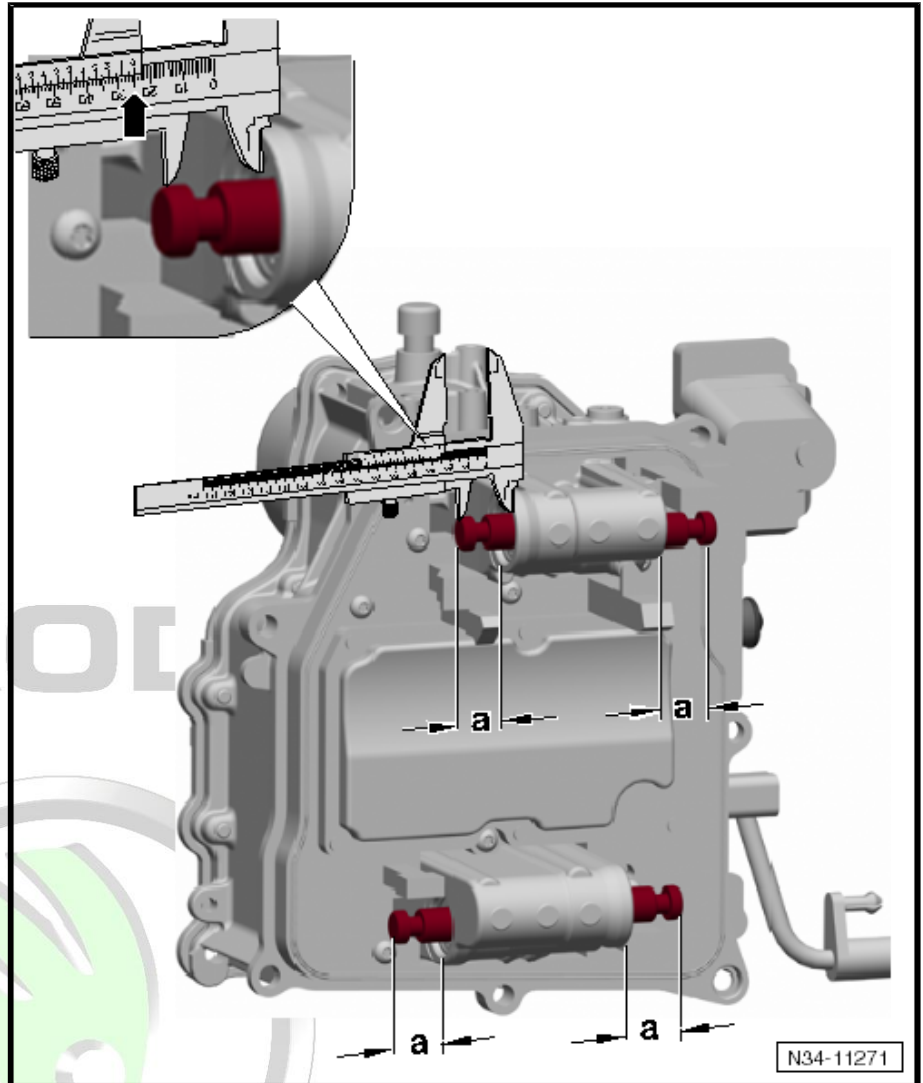

- Set the 4 gear actuators on the rear side of the mechatronics for double clutch gearbox -J743- into the specified position.

Specified position: -a- = 25 mm



Note

The seal for mechatronics for double clutch gearbox -J743- must be attached all around.

- Check the sender. The clip must not be damaged.
- Install mechatronics.

When handling and installing, make sure that the shift forks are not unintentionally pressed out of their position. Also pay attention to the engaging lever and the tappet of the mechatronics.

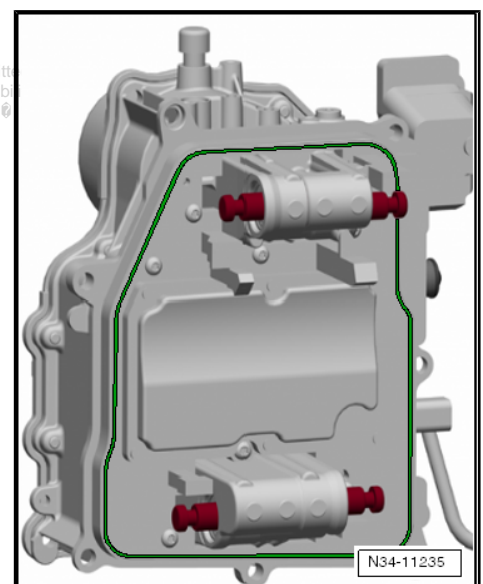



- Screw in the screws -A- (3 pieces, M8 x 35) and -B- (2 pieces, M8 x 90) crosswise by hand.
- Remove guide bolts -T10406- .
- Screw in the remaining screws -B- (2 pieces, M8 x 90) by hand.

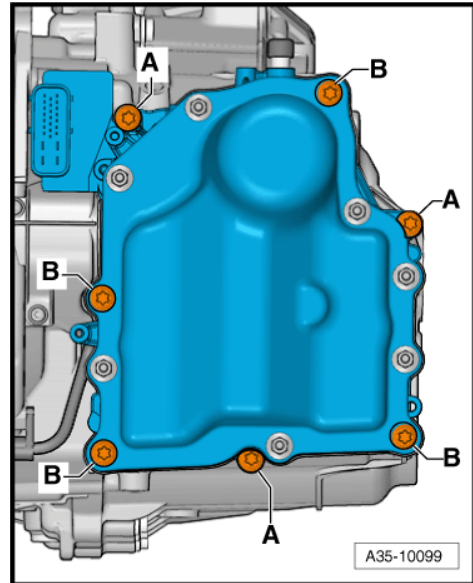

Make sure that the tappets fall precisely into the engaging lever bearing. Pull out the tappets by hand until they fit in these bearings.

- Now check the position of the tappets once again.

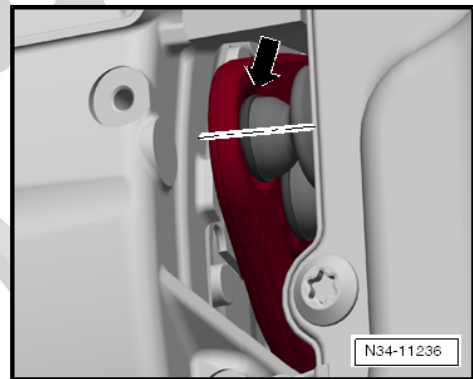

Note

Incorrectly mounted tappets will damage the mechatronics.

Protected by copyright. Copying for private or commercial purposes, in part or in full, without the written permission of ŠKODA AUTO A. S. ŠKODA AUTO A. S. does not accept any responsibility with respect to the correctness of information in this document. Copyright © ŠKODA AUTO A. S. 2009

- Tighten all the screws for the mechatronics for double clutch gearbox -J743- crosswise to the recommended tightening torque => [page 69](#) .
- Turn the assembly lever -T10407 - "slowly and carefully" to the right and remove it.
- Both clutch adjusters must correctly lock in the recesses of the engaging levers for the clutch.
- While doing so, the rubber grommets of the clutch actuators should not be damaged.
- The rubber grommets must rest on the mechatronics.
- An incorrect assembly or damage to the rubber grommets leads to oil leakage in the mechatronics.

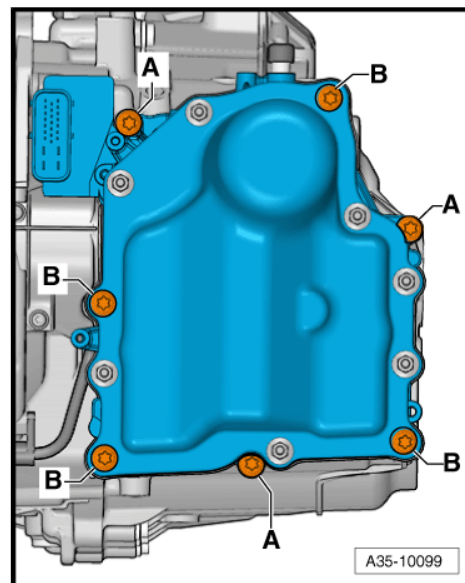

- Position the gearbox input r.p.m. sender -G182- in the -direction of arrow- on the gearbox housing.



Note

The sender must be completely and firmly positioned with the belt buckle tongue on the gearbox housing. If the switch is "loose", replace the mechatronics.

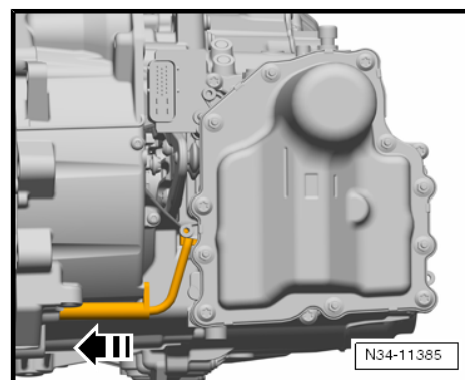

- Remove the screw plug from the ventilation and position the ventilation cap.



Caution

◆ ***Under no circumstances must the plug contacts in the plug of the gearbox be touched with the hands, because the control unit can be destroyed through static discharge as well as the mechatronics.***

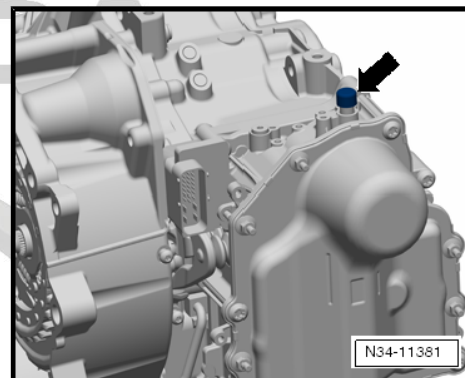

- Grab with the hand (without gloves) at the mass, in order to discharge yourself electrostatically.
- Mount the plug of the mechatronics and lock.
- Attach all the holders and cables again on the gearbox.
- Install fan shroud with fans => Engine => Rep. Gr. 19 .

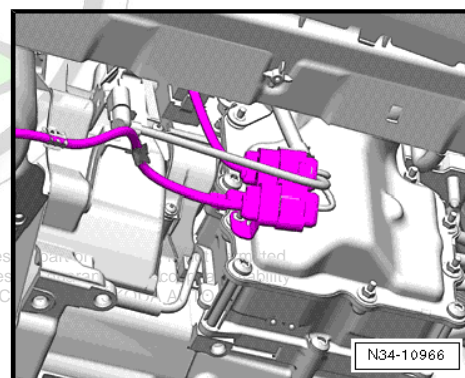

Protected by copyright. Copying for private or commercial purposes unless authorised by ŠKODA AUTO A. S. ŠKODA AUTO A. S. does not accept any liability with respect to the correctness of information in this document. ©



- Attach the bottom coolant hose -1- at the radiator ⇒ Engine ⇒ Rep. Gr. 19 .
- Fit on plug -2- and fill up with coolant ⇒ Engine ⇒ Rep. Gr. 19 .
- Install charge air hose ⇒ Engine ⇒ Rep. Gr. 21 .
- Install the bottom noise insulation ⇒ Body Work ⇒ Rep. Gr. 50 .
- Pour in gear oil ⇒ [page 106](#) .
- Inspect setting of selector lever control cable; adjust if necessary ⇒ [page 49](#) .
- Install battery tray and battery ⇒ Electrical System ⇒ Rep. Gr. 27 .
- Install air filter ⇒ Engine ⇒ Rep. Gr. 24 .

If the battery earth strap is disconnected and connected, carry out certain additional operations ⇒ Electrical System ⇒ Rep. Gr. 27 .

- Connect battery ⇒ Electrical System ⇒ Rep. Gr. 27 .

After the installation of the mechatronics , perform a basic setting with the ⇒ Vehicle diagnosis, testing and information system VAS 5051.

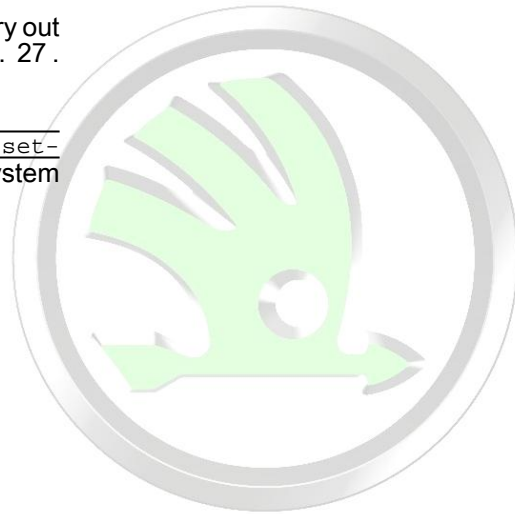
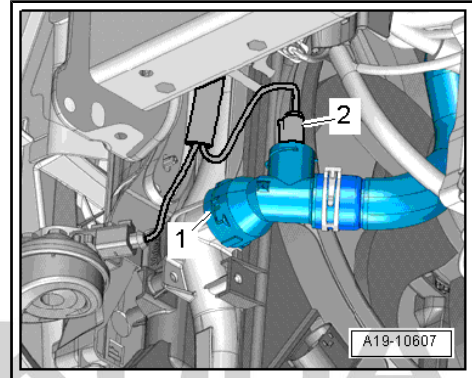

Protected by copyright. Copying for private or commercial purposes, in part or in whole, is not permitted unless authorised by ŠKODA AUTO A. S. ŠKODA AUTO A. S. does not guarantee or accept any liability with respect to the correctness of information in this document. Copyright by ŠKODA AUTO A. S. ©

4 Removing and installing the gearbox

Special tools and workshop equipment required

- ◆ Removal tool for the inner lining of the door panel -MP8-602/1-
- ◆ Supporting device -T30099-
- ◆ Shim -T30099/1-
- ◆ Hook for MP9-200 and T30099 -MP9-200/10 (10-222A/10)-
- ◆ Gearbox mount -3282-
- ◆ Wedge -T10161-
- ◆ Bolt -3282/29-
- ◆ Adjusting plate -3282/59-
- ◆ Extractor -T10037-
- ◆ Tensioning strap -T10038-
- ◆ Engine/gearbox jack , e.g. -V.A.G 1383 A-
- ◆ Spring strap clips , e.g. -VAS 6340-
- ◆ Socket insert e.g. -T10035 - or socket insert XZN 14 -T10061-

Note

- ◆ *Observe instructions for automatic gearbox DSG - 0AM ⇒ [page 4](#) .*
- ◆ *General repair information ⇒ [page 4](#) .*
- ◆ *All cable straps which are detached or cut open when removing, should be fitted on again in the same place when installing.*
- ◆ *If the battery earth strap is disconnected and connected, carry out certain additional operations ⇒ Electrical System ⇒ Rep. Gr. 27 .*
- ◆ *Gearbox with different output shafts:*
 - ◆ -A- up to 11.08 - rigid shaft
 - ◆ -B- as of 11.08 - flange shaft

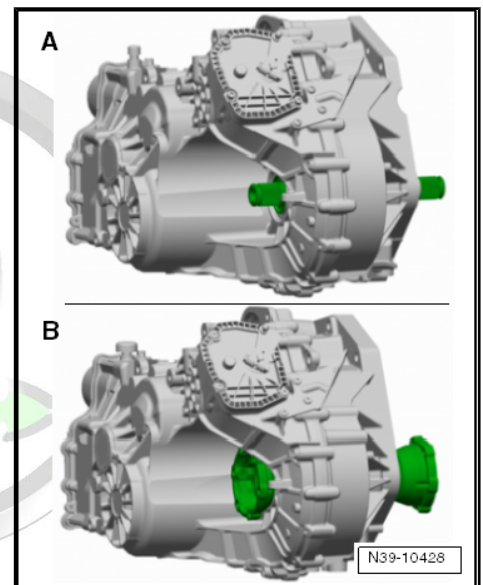

4.1 Removing the gearbox

- Shift selector lever into position "P".

Note

Do not take out ignition key.

- Remove engine cover ⇒ Engine ⇒ Rep. Gr. 10 (if present).
- Remove air filter ⇒ Engine ⇒ Rep. Gr. 24 .
- Remove battery and battery tray ⇒ Electrical System ⇒ Rep. Gr. 27 .
- Remove the cooling water tank cover ⇒ Body Work ⇒ Rep. Gr. 66 .



- Expose the selector lever control cable -A- from the gearbox shift lever with the removal tool for the inner lining of the door panel -MP8-602/1- .

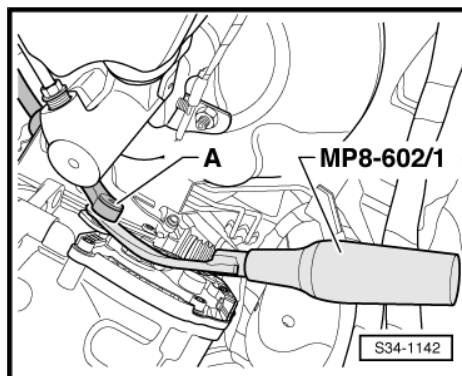

- Remove the lock washer -arrow- for the selector lever control cable, the selector lever control cable must be left in the fitting position.



Note

- ◆ *The lock washer -1- of the selector lever control cable must always be replaced ⇒ Electronic Catalogue of Original Parts .*
- ◆ *Do not bend or buckle selector lever control cable.*
- ◆ *Do not press the selector lever control cable out of the cable support towards the rear. The selector lever control cable is only unclipped out of the cable support when removing the gearshift mechanism.*

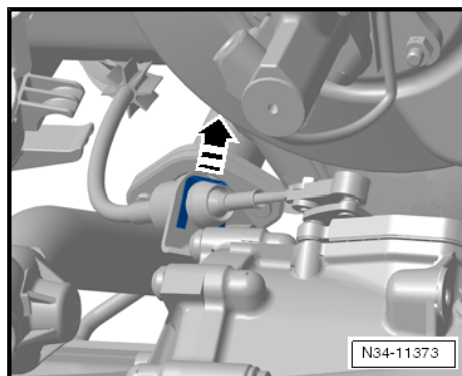

- Remove the earth lead -1- from the fixing screw of the gearbox console.
- Remove plug and cable from starter ⇒ Electrical System ⇒ Rep. Gr. 27 .
- Unscrew screw -arrow°A- from starter.



Note

Unscrew the second fixing screw from the starter (not visible in the illustration) and remove starter -2-.

- Unscrew the connecting screws -arrows B- at engine and gearbox. To this end, use if necessary the socket insert -T10035- .
- Disconnect the cable connection -3- from the holder with attached electrical cables -4- and tie up.
- Remove the holder -4- from the gearbox.

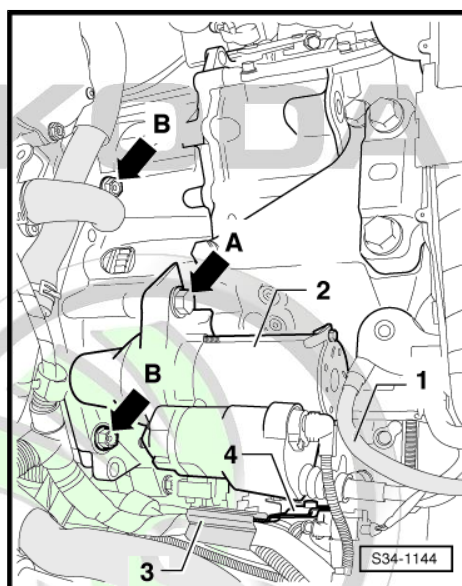

One of the screws is located in the starter opening (only on certain types of engines e.g. on 1.4 engines).

- Screw out this screw.



Caution

- ◆ *Under no circumstances must the plug contacts in the plug of the gearbox be touched with the hands, because the control unit can be destroyed through static discharge as well as the mechatronics.*

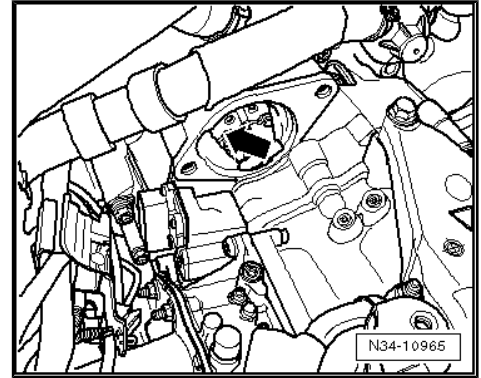

- Grab with the hand (without gloves) at the vehicle mass, so that it discharges electrostatically.
- Unlock the cap of the plug on the mechatronics by pulling in -direction of arrow- and disconnect the plug.

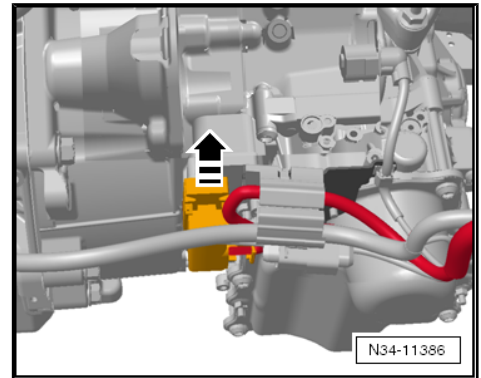

- Fit supporting device -T 30099- .
- Slightly pre-tension the engine/gearbox assembly via the spindle (do not raise) (use only one spindle of the supporting device on 1.2/77 kW engine).

Only on vehicles with rigid shaft (up to 11.08)

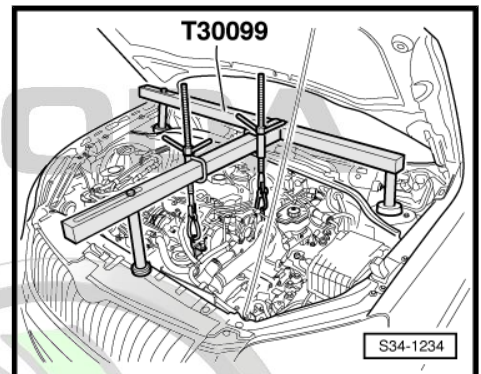



- Actuate the brake pedal and slacken the left drive shaft bolt -arrow- (second mechanic).
- Loosen the wheel bolts on front left and front right.
- Raise vehicle.

Continued for all vehicles

- Remove wheels at the front.



Note

After slackening the drive shaft bolt -arrow- the vehicle must no longer be lowered onto the floor.

- Remove bottom noise insulation ⇒ Body Work ⇒ Rep. Gr. 50 .
- Remove the front left wheelhouse liner ⇒ Body Work ⇒ Rep. Gr. 66 .
- Remove the charge air hose from the bottom left charge air cooler and the charge air pipe ⇒ Engine ⇒ Rep. Gr. 21 .
- Remove the screen cap for the right drive shaft from the engine -arrows-.

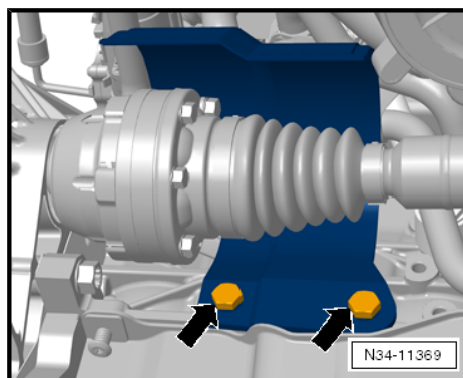
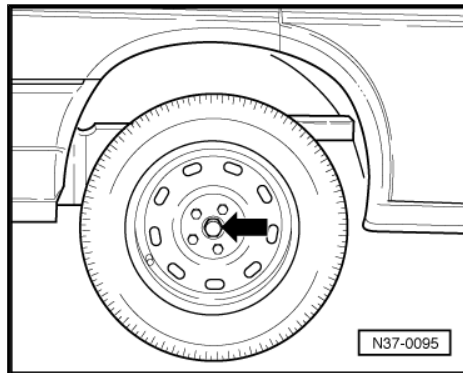

- Remove pendulum support, to do so screw out screws -arrows A, B and C-.
- Separate exhaust system at the clamping sleeve and remove bracket for the exhaust system from the assembly carrier ⇒ Engine ⇒ Rep. Gr. 26 .
- Tie up pre-exhaust pipe.

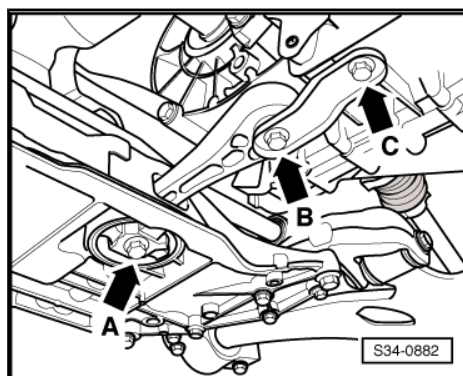

- Disconnect electrical plug connection -1- at oil level and oil temperature sender -G266- .
- Unhook the wiring loom from the holder -2-.
- Remove coupling rod from anti-roll bar.
- Fix the assembly carrier before removing ⇒ Chassis ⇒ Rep. Gr. 40 .
- Remove the assembly carrier with console without steering gear, left track control arm and coupling rod ⇒ Chassis ⇒ Rep. Gr. 40 .

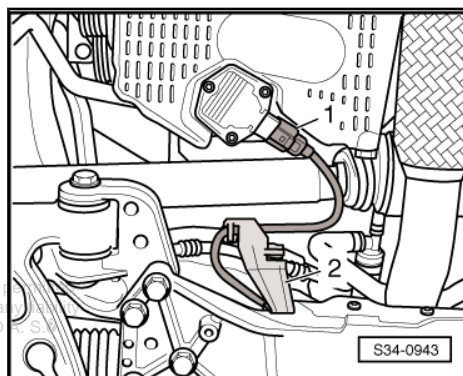

Only on vehicles with rigid shaft (up to 11.08)

- If present, remove front left vehicle level sensor -G78- .

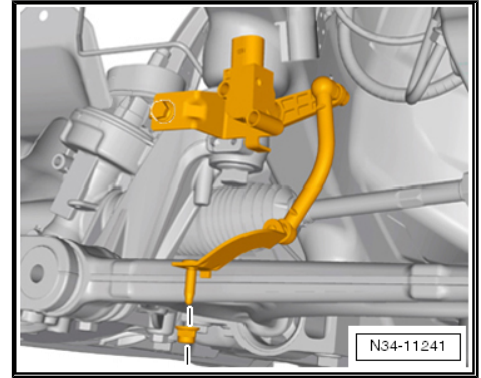

- Unscrew the nuts -arrows- from the steering joint to the right track control arm.
- Unhook the steering joints from the track control arms.
- Press off the left and right drive shaft from the rigid shafts of the gearbox e.g with wedge -T10161- or tyre iron => Chassis => Rep. Gr. 40 .
- Remove left drive shaft => Chassis => Rep. Gr. 40 .

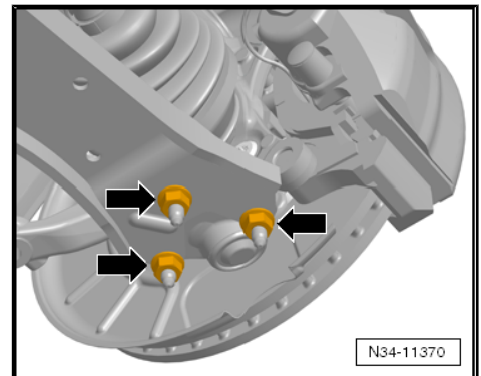

- Tie up the right drive shaft as far as possible. Avoid damaging the paintwork on the drive shaft during this operation.

Only on vehicles with flange shaft (as of 11.08)

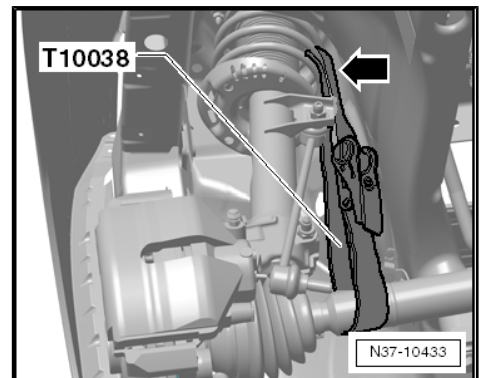
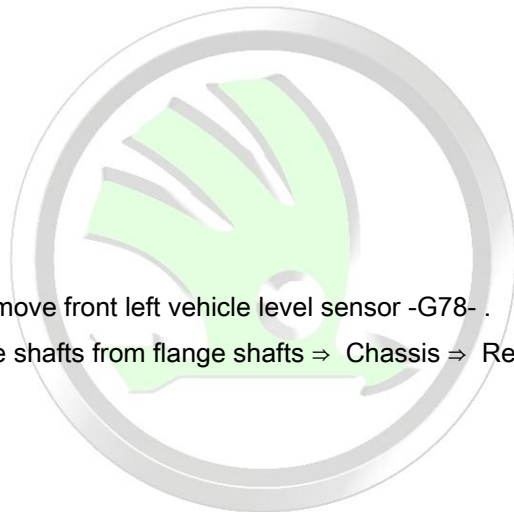

- If present, remove front left vehicle level sensor -G78- .
- Remove drive shafts from flange shafts => Chassis => Rep. Gr. 40 .

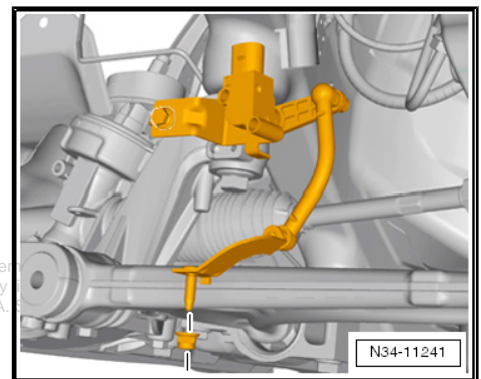

Protected by copyright. Copying for private or commercial purposes, in part or in whole, is not permitted unless authorised by ŠKODA AUTO A. S. ŠKODA AUTO A. S. does not guarantee or accept any liability with respect to the correctness of information in this document. Copyright by ŠKODA AUTO A. S.

- Tie up the drive shafts as far as possible. Avoid damaging the paintwork on the drive shaft during this operation.

Continued for vehicles with 1.2 and 1.4 engines

On the 1.4 engine separate the front exhaust system, the exhaust system must not be separated on the 1.2 engine.

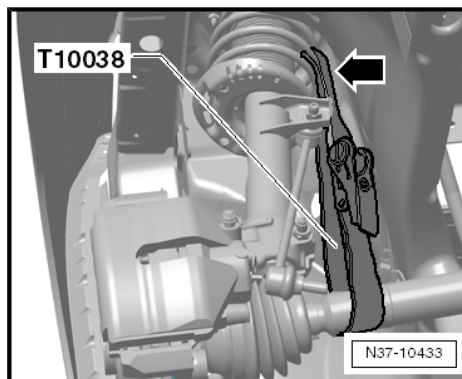

- Unscrew the bottom engine/gearbox connecting screws -arrows-.

Continued for all vehicles

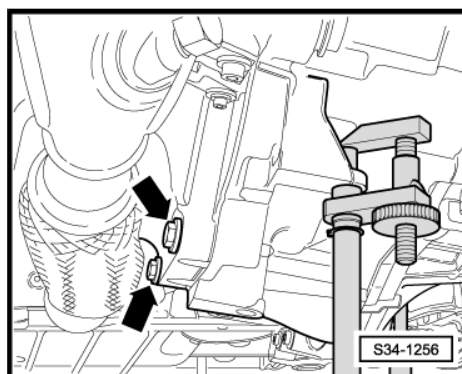

- Unscrew bottom connecting screws -arrow°A- and -arrow°B- from engine/gearbox.

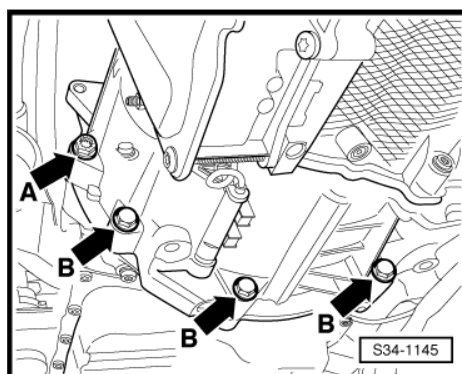
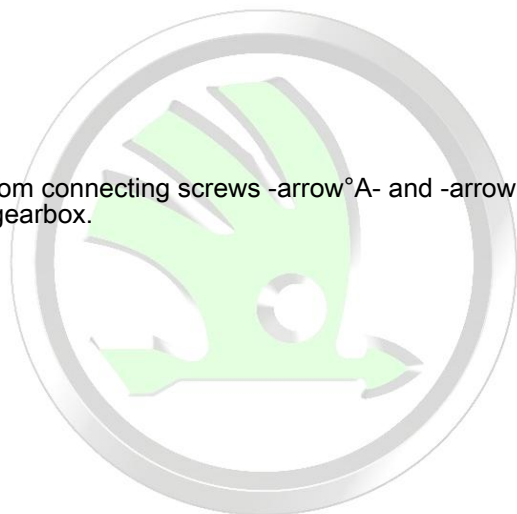

Protected by copyright. Copying for private or commercial purposes, in part or in whole, is not permitted without the prior written consent of ŠKODA AUTO A.S. All rights reserved. ŠKODA AUTO A.S. is not responsible for any errors or omissions in this document.

Slacken the screws -1- of the gearbox console by approx. one turn and screw out the screws -2-.

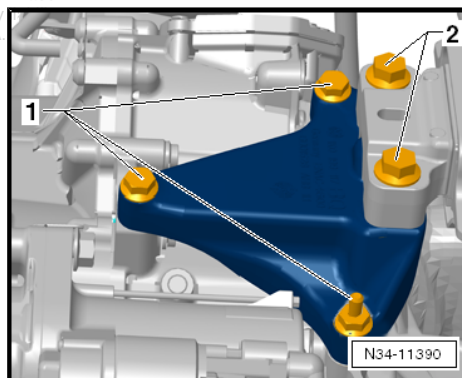

- Then lower the engine and gearbox via the spindles of the supporting device -MP9-200 (10 - 222 A)- as far as necessary so that there is a gap of dimension -a- between the gearbox console and the gearbox mount.
- Dimension -a- = 60 ... 70°mm

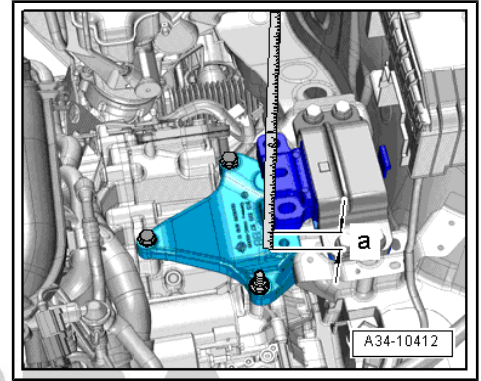

- Screw out screws -arrows- and remove gearbox console.

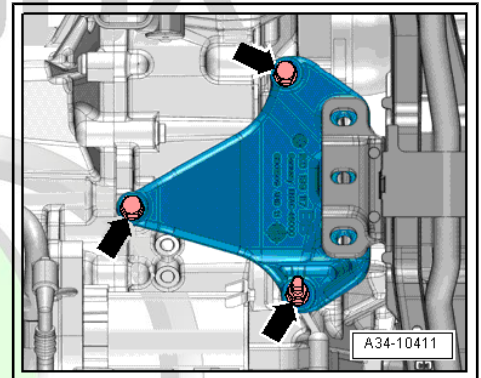

For the removal of the gearbox 0AM the gearbox mount -3282- is aligned with the adjusting plate -3282/59- and placed on the engine/gearbox jack -V.A.G 1383 A- .

- Align arms of the gearbox mount to match the holes in the adjusting plate -3282/59- .
- Screw in the mounting elements as shown on adjusting plate -3282/59- .
- Position the engine and gearbox jack -V.A.G 1383 A- below the vehicle.
- The arrow symbol on the adjusting plate -3282/59- points in the direction of travel.
- Align the gearbox mount -3282- parallel to the gearbox.
- Screw the bolt -3282/29- into the gearbox.
- Place both remaining mounting elements on the gearbox as shown. To do so, place the panel of the drift under the gearbox housing and not under the mechatronics.
- Secure the gearbox with the tensioning strap -T10038- .
- Support the gearbox by lifting the engine and gearbox jack -V.A.G 1383 A- from the bottom.

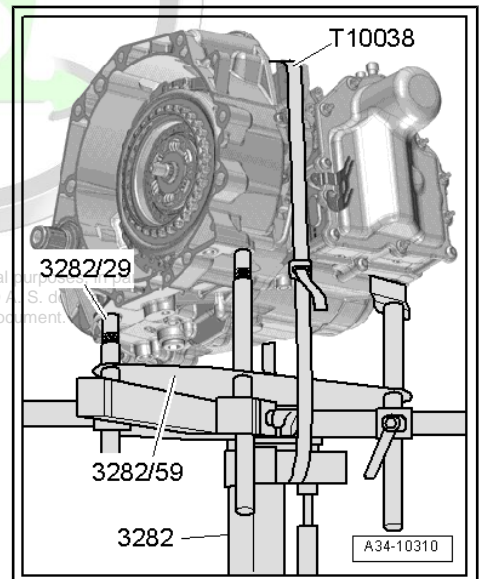



- Screw out the last engine connecting screw -arrow- at the gearbox.
- Press the gearbox out of the sleeves.
- Carefully separate the gearbox from the engine and carefully lower.
- When lowering the gearbox, guide the selector lever control cable out of the cable support.

**Note**

- ◆ *Observe all lines and coolant hoses when lowering the gearbox.*
- ◆ *Do not bend or buckle selector lever control cable.*

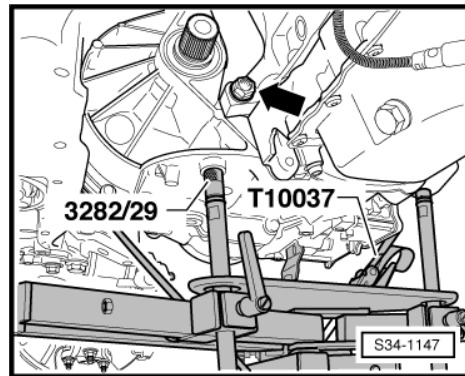

In some cases, the brackets are located at the front of the gearbox.

**Note**

If a "new" gearbox must be installed, the brackets must be fitted to the "new" gearbox.

Transporting the gearbox and secure to the assembly support
⇒ [page 104](#) .

Installing the gearbox ⇒ [page 100](#) .

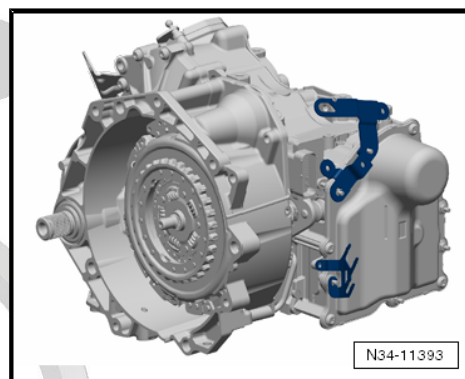

4.2 Installing the gearbox

Installation is performed in the reverse order, pay attention to the following points:

**Note**

- ◆ *When performing installation work replace the self-locking nuts and screws.*
- ◆ *Replace screws which have been tightened to a torquing angle as well as gasket rings and seals.*
- ◆ *Secure all hose connections with hose clamps which comply with the series design ⇒ Electronic Catalogue of Original Parts .*
- ◆ *All cable straps which are detached or cut open when removing, should be fitted on again in the same place when installing.*
- ◆ *The lock washer of the selector lever control cable must always be replaced ⇒ Electronic Catalogue of Original Parts .*
- ◆ *Replace the needle bearing -arrow- in the crankshaft ⇒ Engine ⇒ Rep. Gr. 13 .*
- ◆ *Check whether the dowel sleeves for centering the engine/ gearbox are present in the cylinder block; insert if necessary.*
- ◆ *If the gearbox is inserted, ensure the intermediate plate between the engine and gearbox is correctly installed.*

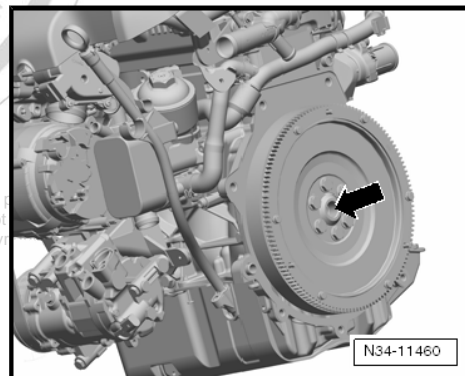

- Replace O-ring -1- at rigid shafts, if no new gearbox is installed.
- Replace circlip -2- at rigid shafts, if no new gearbox is installed.

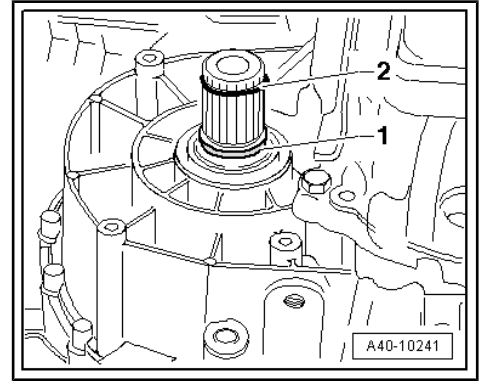

- Carefully raise gearbox with the engine and gearbox jack - V.A.G 1383 A- and put in its installation position with the gearbox mount -3282- .

 **Note**

- ◆ Insert the selector lever control cable in the cable support when raising the gearbox.
- ◆ Do not bend or buckle selector lever control cable.
- ◆ Observe all lines and coolant hoses when raising the gearbox.

- Adjust the gearbox mount -3282- via the spindles in such a way that the engine and the gearbox are "aligned".

The engine and the gearbox must be moved together by hand until the engine flange and the gearbox flange touch each other all around!

- Screw the gearbox onto the engine, while doing so turn the crankshaft further if necessary.

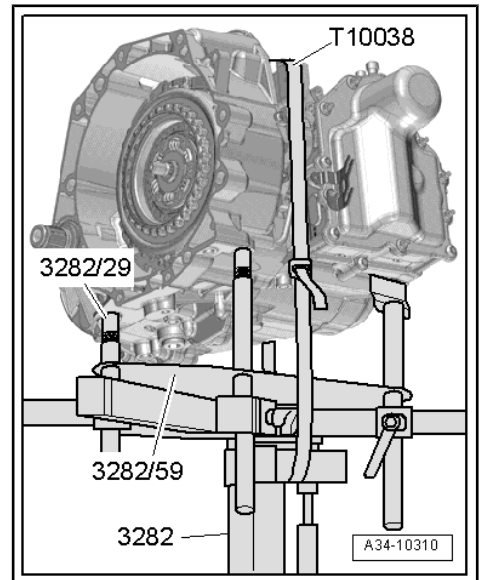

Install the unit mounting as follows:

- Insert the gearbox console -1- between the gearbox and the supporting arm of the gearbox mount.
- Screw the gearbox console -1- with new screws to the gearbox.
- Evenly lift up the gearbox via the spindle of the supporting device -MP9-200 (10 - 222 A)- to the supporting arm of the gearbox mount.
- First of all tighten the screws -arrows- by hand.

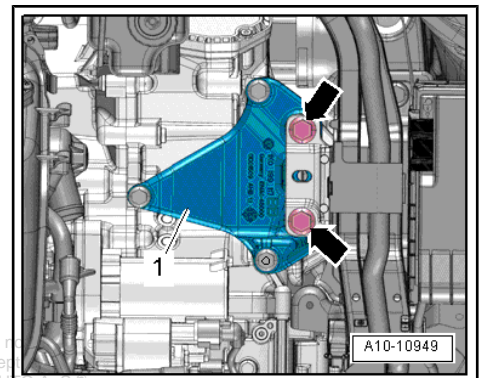

 **Caution**

Before screwing in the screws -arrows- the gearbox console must be absolutely parallel to the supporting arm of the gearbox mount, otherwise the thread is damaged.

- Remove the gearbox mount -3282- from the gearbox.



- Install the pendulum support with new screws -arrows A, B, and C- ➔ Chassis ➔ Rep. Gr. 40 .
- Install the left drive shaft and the right drive shaft ➔ Chassis ➔ Rep. Gr. 40 .

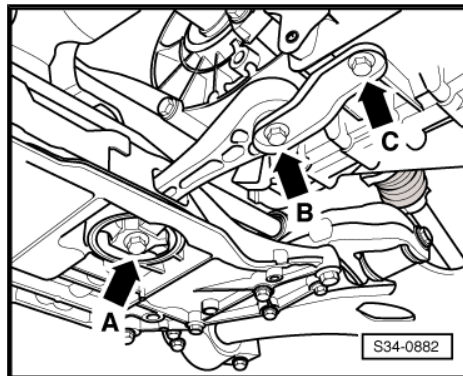

- Screw the steering joints to the track control arms -arrows- ➔ Chassis ➔ Rep. Gr. 40 .

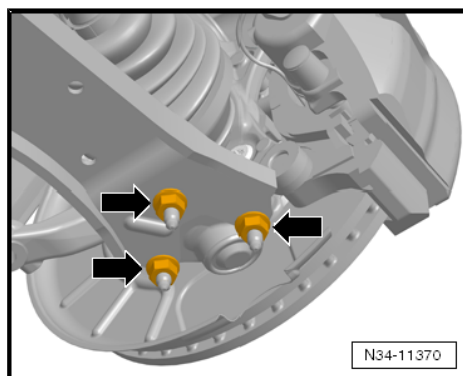

- Install the screen cap for the right drive shaft on the engine, to do so tighten the screws -arrows- to 35 Nm.
- Install the charge air hose between the bottom left charge air cooler and the charge air pipe ➔ Engine ➔ Rep. Gr. 21 .
- Assemble exhaust system free of stress and install bracket for the exhaust system at the assembly carrier ➔ Engine ➔ Rep. Gr. 26 .
- Install the starter ➔ Electrical System ➔ Rep. Gr. 27 .
- Tighten the new screws of the gearbox mount to the gearbox console with recommended tightening torque ➔ [page 103](#) .
- Remove supporting device -MP9-200 (10 - 222 A)- .

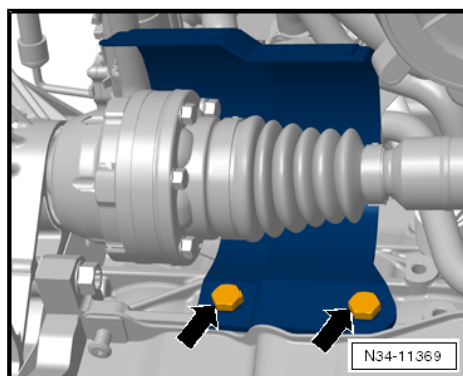

- Carefully press the selector lever control cable -2- onto the lever/gearshift shaft of the gearbox and secure in the cable support with a new lock washer -1-.
- Install battery tray and battery ⇒ Electrical System ⇒ Rep. Gr. 27 .
- Inspect setting of selector lever control cable and adjust ⇒ [page 49](#) .
- Install air filter ⇒ Engine ⇒ Rep. Gr. 24 .
- Install the front left wheelhouse liner ⇒ Body Work ⇒ Rep. Gr. 66 .
- Install the bottom noise insulation ⇒ Body Work ⇒ Rep. Gr. 50 .
- Install front wheels ⇒ Chassis ⇒ Rep. Gr. 44 .
- If the front left vehicle level sensor -G78- was removed, then the headlight beam setting must be checked ⇒ Electrical System ⇒ Rep. Gr. 94 .

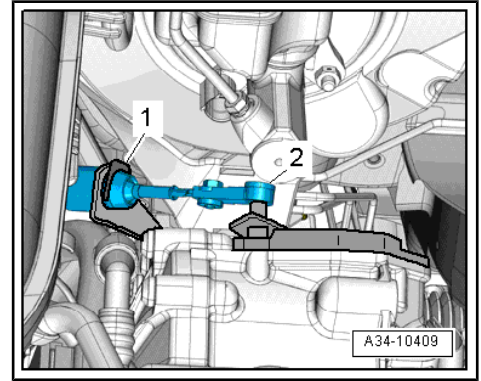

Perform the **basic setting** after the gearbox has been fitted with the ⇒ Vehicle diagnosis, testing and information system VAS 5051.

4.2.1 Tightening torques

Attachment of gearbox to engine for vehicles 1.2

Pos.	Screw	Nm
1,2	M12 x 65	80
3	M12 x 50	80
4,5	M12 x 65	80
6 ¹⁾ , 7 ¹⁾	M10 x 25	40
8 ¹⁾	M12 x 65	80
A	Dowel sleeves	

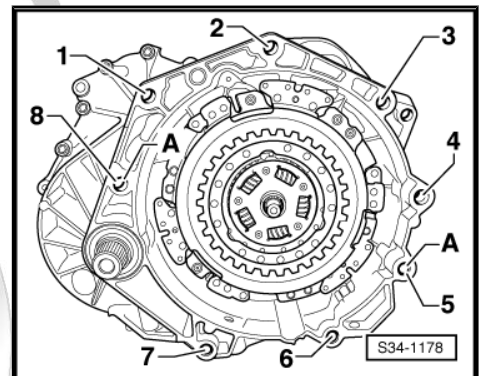

¹⁾ Screwed in from the engine side

Gearbox console to gearbox and gearbox mount to gearbox console

- ◆ Screw -1- tightening torque 40 Nm + torque a further 90° (1/4 turn)
- ◆ Screw -2- tightening torque 60 Nm + torque a further 90° (1/4 turn)

Always replace screws -1- and -2- ⇒ Electronic Catalogue of Original Parts .

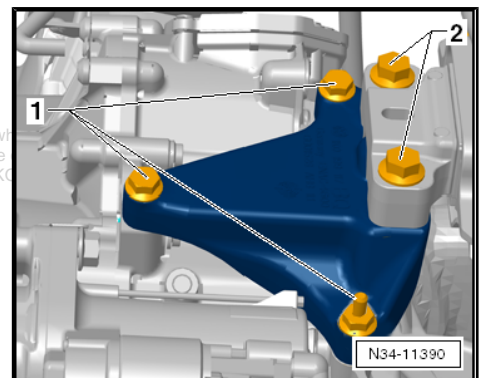



5 Transport the gearbox and secure to the assembly support

Special tools and workshop equipment required

- ◆ Ring bolt -3368- (2 pieces)
- ◆ Lifting eye -10 - 222 A /12-
- ◆ Gearbox mount -T30109 (VW 353)-
- ◆ Gearbox mount -T30108-
- ◆ Lifting device -MP9-201 (2024 A)-
- ◆ Assembly stand -MP9-101-

Transporting the gearbox

- Screw the ring bolt -3368- into the threaded bore of the gearbox up to the stop and secure with nut M10. Then hang the workshop crane in the lifting eye -10 - 222 A /12- .

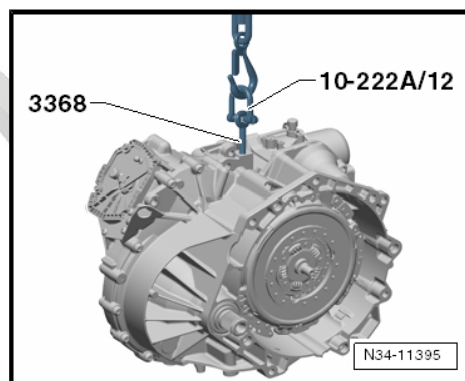

Secure the gearbox in the gearbox mount -T30109 (VW 353)-

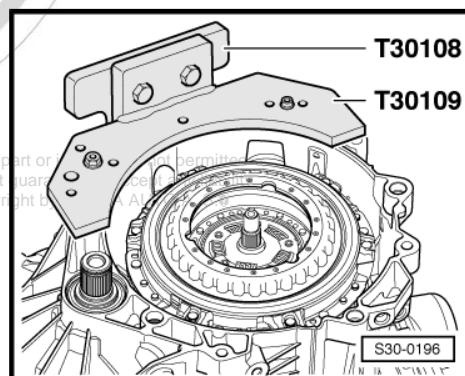

Note

Before the gearbox can be turned horizontally, both ventilation caps -arrows- must be removed and the openings must be closed with suitable screw plugs so that no oil can flow out.

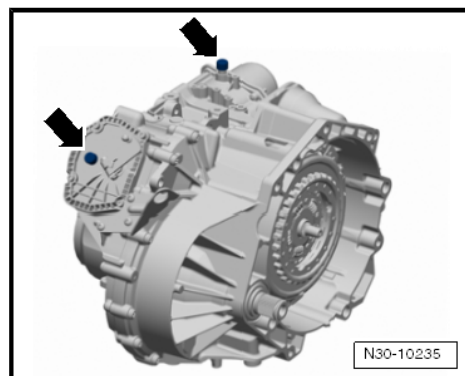

Lift up the gearbox on the assembly stand -MP9-101-

The gearbox is raised together with the gearbox mount -T30109 (VW 353)- at the assembly stand .

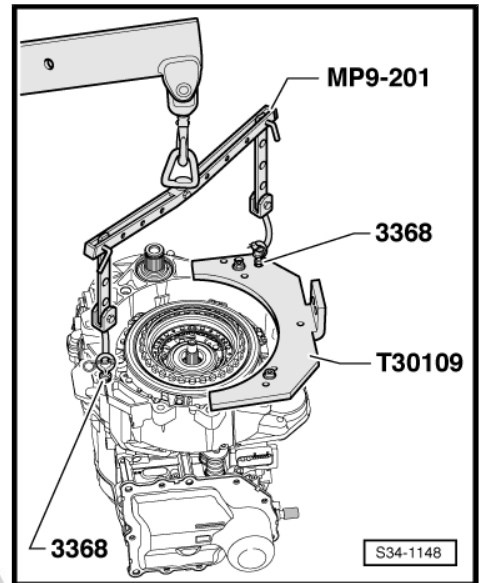

Attach gearbox to assembly stand -MP9-101- .

- The gearbox holder -T30109 (VW 353)- is screwed on the gearbox holder -T30108- with screws -arrows-.

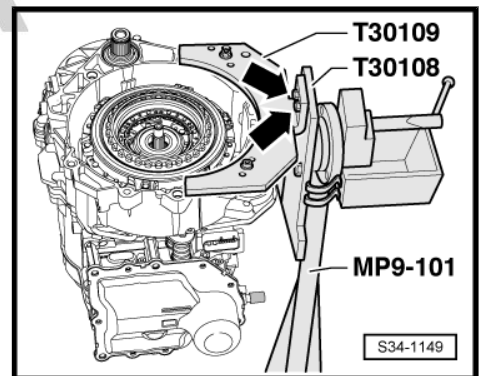

Protected by copyright. Copying for private or commercial purposes, in part or in whole, is not permitted unless authorised by ŠKODA AUTO A. S. ŠKODA AUTO A. S. does not guarantee or accept any liability with respect to the correctness of information in this document. Copyright by ŠKODA AUTO A. S. ©



6 Change gearbox oil

Special tools and workshop equipment required

- ◆ Removal tool for the inner lining of the door panel -MP8-602/1-
- ◆ Sealing grease -G 052 128 A1-
- ◆ Catch pan



Note

- ◆ *The gear oil filling is permanent for the "7-speed automatic gearbox DSG - 0AM" (oils are designed to be filled for life). For this reason the oil level is not checked and the inspection plug is not present on this gearbox.*
- ◆ *Observe the general repair instructions ⇒ [page 4](#) .*
- ◆ *If the battery earth strap is disconnected and connected, carry out certain additional operations ⇒ Electrical System ⇒ Rep. Gr. 27 .*

In case of leaks on the gearbox, the cause must be determined and the fault rectified.

Then the oil must be completely drained and filled up with new oil.

- Raise vehicle.
- Position the catch pan under the gearbox.
- Release oil drain plug -arrow- at the gearbox.

Protected by copyright. Copying for private or commercial purposes, in part or in whole, is not permitted without the express written consent of ŠKODA AUTO A. S. ŠKODA AUTO A. S. does not guarantee or accept any liability with respect to the correctness of information in this document. Copyright by ŠKODA AUTO A. S.

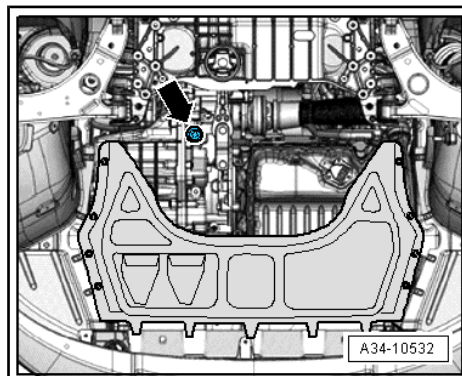

- Drain off oil.
- Install oil drain plug.
- Shift selector lever into position "P".
- Remove air filter ⇒ Engine ⇒ Rep. Gr. 24 .
- Remove battery and battery tray ⇒ Electrical System ⇒ Rep. Gr. 27 .

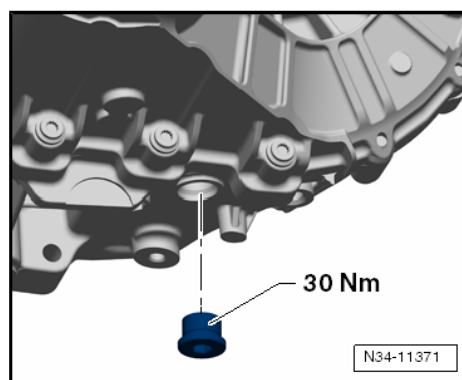

- Expose the selector lever control cable -A- from the gearbox shift lever with the removal tool for the inner lining of the door panel -MP8-602/1- .

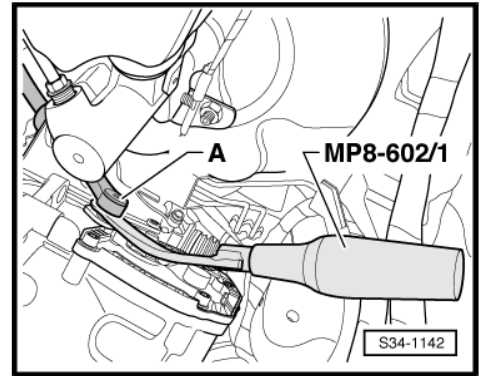

- Remove the lock washer -arrow- for the selector lever control cable, the selector lever control cable must be left in the fitting position.

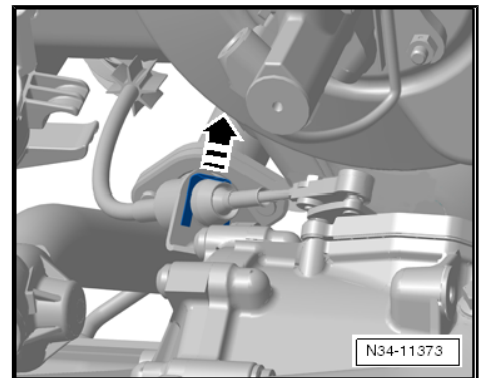

- Position gearbox in "P". To do so, press the gearshift lever by hand up to the stop in the direction towards the cable support -arrow-.

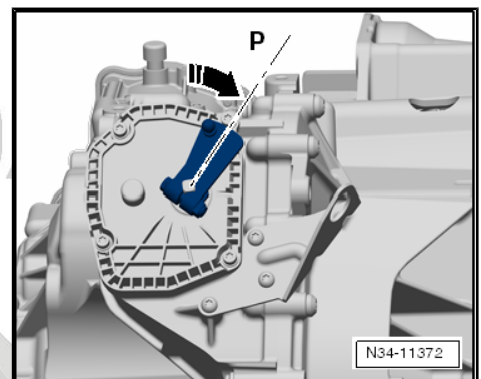

- Remove gearshift lever.
- Unscrew the cover.

 **Note**

- ◆ *The gear oil level cannot be checked.*
- ◆ *The prescribed filling capacity must be precisely respected.*
- ◆ *Only then the gearbox is correctly filled.*
- ◆ *An over-filling as well as an under-filling impair the proper operation of the gearbox.*

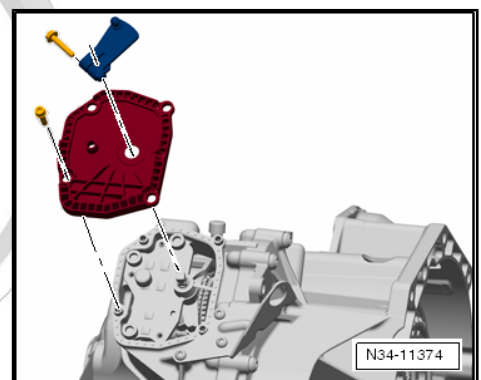

Protected by copyright. Copying for private or commercial purposes, in part or in whole, is not permitted unless authorised by ŠKODA AUTO A. S. ŠKODA AUTO A. S. does not guarantee or accept any liability with respect to the correctness of information in this document. Copyright by ŠKODA AUTO A. S. ©



- Top up with 1.7 ltr. oil through the opening -arrow-.
- Clean the sealing surface on the gearbox and the cover.



Note

- ◆ Grease cover seal with grease -G 052 128 A1- .
- ◆ Always replace screw from gearshift lever ⇒ *Electronic Catalogue of Original Parts* .

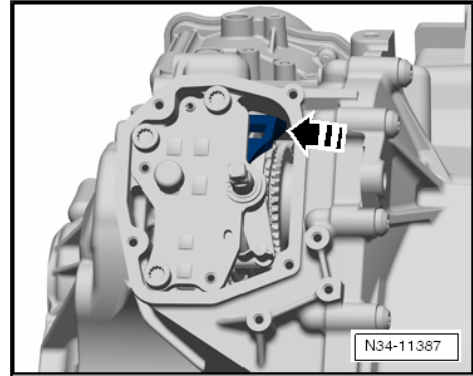

- Install the cover and the gearshift lever again.

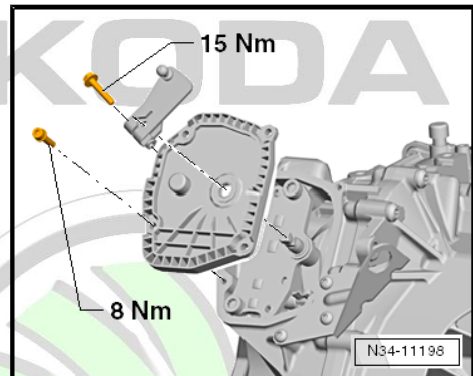

- Carefully press the selector lever control cable -2- onto the lever/gearshift shaft of the gearbox and secure in the cable support with a new lock washer -1-.
- Install battery tray and battery ⇒ Electrical System ⇒ Rep. Gr. 27 .
- Inspect setting of selector lever control cable and adjust ⇒ [page 49](#) .
- Install air filter ⇒ Engine ⇒ Rep. Gr. 24 .

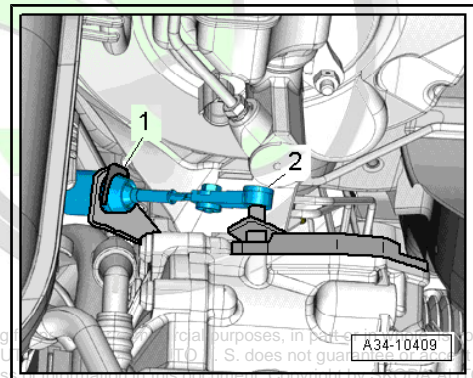

Protected by copyright. Copying or reproduction in any form or by any means, electronic, mechanical, photocopying, recording, or by any information storage and retrieval system, is prohibited without the prior written permission of ŠKODA A.S. ŠKODA A.S. does not guarantee the accuracy of the information provided in this manual. Copyright by ŠKODA A.S.



35 – Wheels, shafts

1 Pinions and shafts

At present no repairs are carried out on the pinions and shafts.

ŠKODA



Protected by copyright. Copying for private or commercial purposes, in part or in whole, is not permitted unless authorised by ŠKODA AUTO A. S. ŠKODA AUTO A. S. does not guarantee or accept any liability with respect to the correctness of information in this document. Copyright by ŠKODA AUTO A. S. ©

39 – Final drive, differential gear

1 Replace gasket rings for rigid shafts and flange shafts

1.1 Summary of components - Gasket rings and rigid shaft

1 - Sealing ring

- for the right rigid shaft
- replace ⇒ [page 114](#)
- for right flange shaft
- replace ⇒ [page 119](#)

2 - Right rigid shaft (up to "11.08")

- removing and installing ⇒ [page 114](#)
- as of "11.08" replaced by flange shaft ⇒ [page 111](#)
- removing and installing ⇒ [page 119](#)

3 - O-ring

- replace ⇒ Electronic Catalogue of Original Parts
- not present if the flange shaft is installed

4 - Circlip

- insert into the round slot of the rigid shaft
- replace ⇒ Electronic Catalogue of Original Parts
- not present if the flange shaft is installed

5 - Conical screw, 30 Nm

- replace ⇒ Electronic Catalogue of Original Parts

6 - Sealing ring

- for the left rigid shaft
- replace ⇒ [page 111](#)
- for left flange shaft
- replace ⇒ [page 117](#)

7 - Left rigid shaft (up to "11.08")

- removing and installing ⇒ [page 111](#)
- as of "11.08" replaced by flange shaft ⇒ [page 111](#)
- removing and installing ⇒ [page 117](#)

8 - O-ring

- replace ⇒ Electronic Catalogue of Original Parts

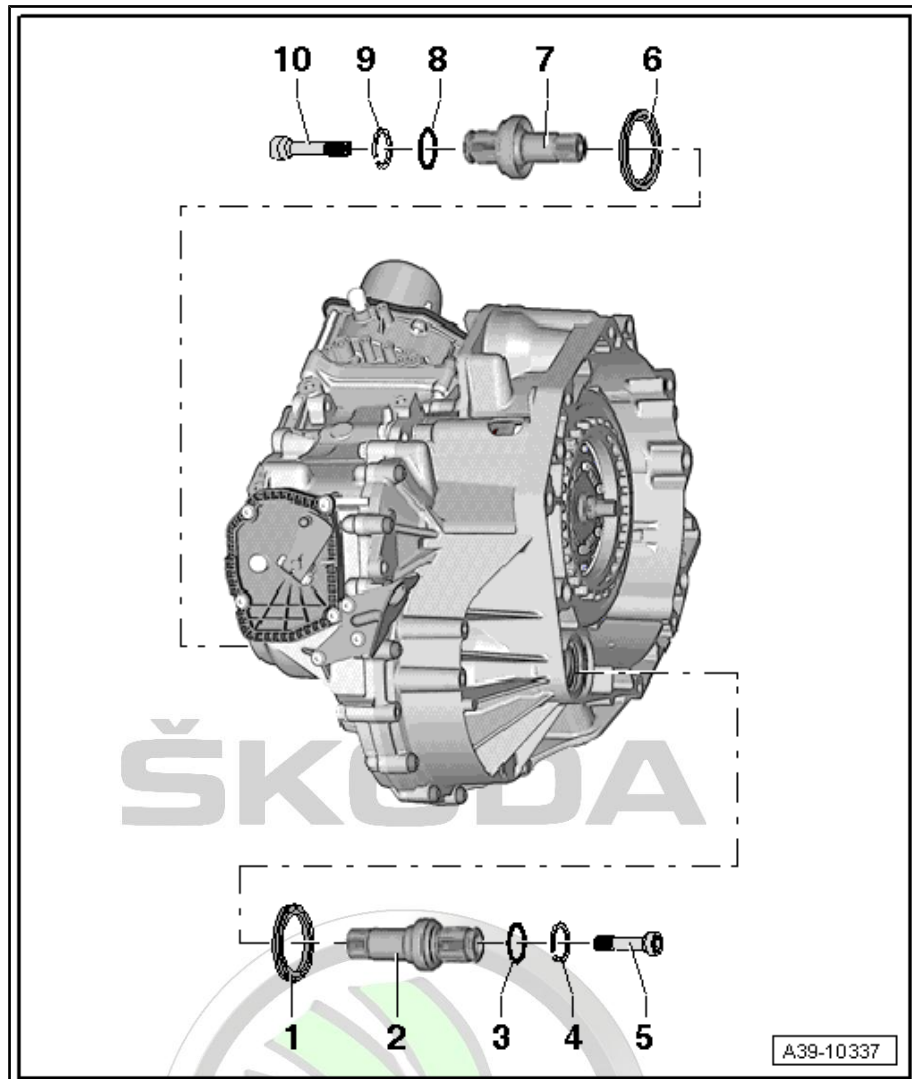



- not present if the flange shaft is installed

9 - Circlip

- insert into the round slot of the rigid shaft
- replace ⇒ Electronic Catalogue of Original Parts
- not present if the flange shaft is installed

10 - Conical screw, 30 Nm

- replace ⇒ Electronic Catalogue of Original Parts

Gearbox with different output shafts

- ◆ -A- up to 11.08 - rigid shaft
- ◆ -B- as of 11.08 - flange shaft

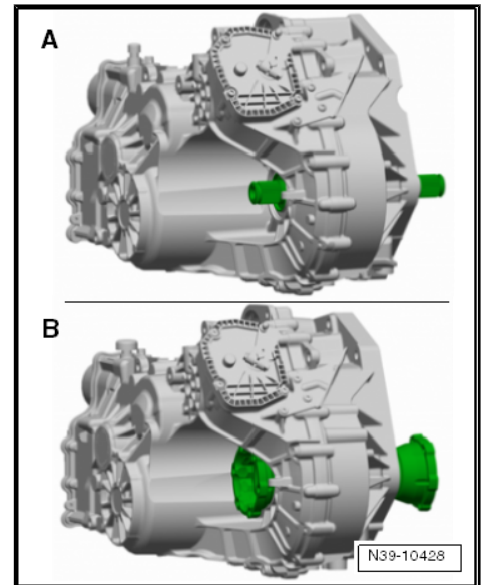

1.2 Replacing left rigid shaft gasket ring

Special tools and workshop equipment required

- ◆ Multi-purpose tool -MP3-419 (VW 771)-
- ◆ Extractor -MP3-419/37 (VW 771/37)-
- ◆ Socket insert -T10107 A- or socket insert 6 mm, commercially available
- ◆ Thrust piece -T30028 (3305)-
- ◆ Tensioning strap -T10038-
- ◆ Sealing grease -G 052 128 A1-
- ◆ Catch pan

1.2.1 Removing



Note

- ◆ *Observe the general repair instructions ⇒ [page 4](#) .*
- ◆ *Do not remove both drive shafts simultaneously from the gearbox. Then it is no longer possible to hold the opposite wheel in order to remove or install the screws of the rigid shafts or flange shafts.*
- ◆ *Do not loosen both fixing screws in the left and right rigid shafts or flange shafts at the same time. If the differential bevel gears twist, it will be difficult to reinstall the screws.*



- Actuate the brake pedal and slacken the left drive shaft bolt -arrow- (second mechanic).



Note

After slackening the drive shaft bolt -arrow- the vehicle must no longer be lowered onto the floor.

- Loosen the front left wheel bolts.
- Raise vehicle.
- Unscrew the front left wheel.
- Remove bottom noise insulation ⇒ Body Work ⇒ Rep. Gr. 50 .
- Remove coupling rod from anti-roll bar.
- Unscrew the nuts -arrows- from the steering joint to the left track control arm.

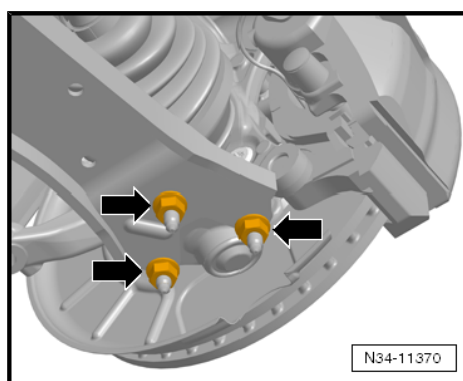
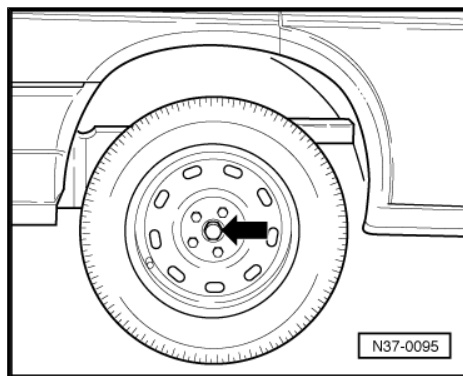

- If present, remove front left vehicle level sensor -G78- .
- Unhook the steering joint from the track control arm.
- Press off the left drive shaft from the rigid shaft of the gearbox e.g with wedge -T10161- or tyre iron ⇒ Chassis ⇒ Rep. Gr. 40 .

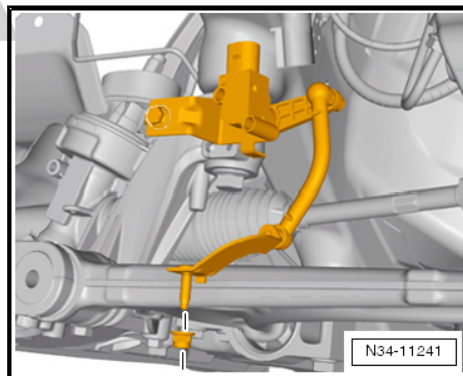

- Tie up the drive shaft as far as possible. Avoid damaging the paintwork on the drive shaft during this operation.
- Position the catch pan under the gearbox.

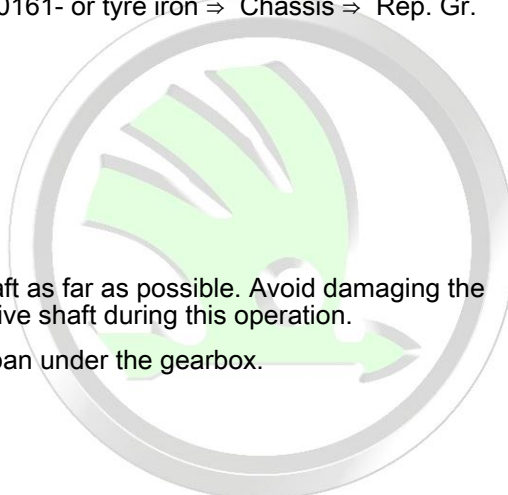
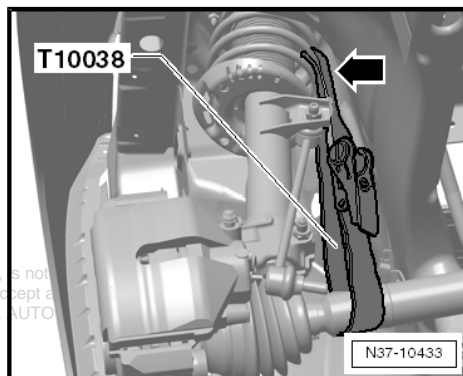

Protected by copyright. Copying for private or commercial purposes, in part or in whole, is not allowed unless authorised by ŠKODA AUTO A. S. ŠKODA AUTO A. S. does not guarantee or accept any liability with respect to the correctness of information in this document. Copyright by ŠKODA AUTO A. S.

- Release the screw in the rigid shaft with the socket insert - T10107 A- or a commercially available 6°mm socket insert.
- Pull out rigid shaft.

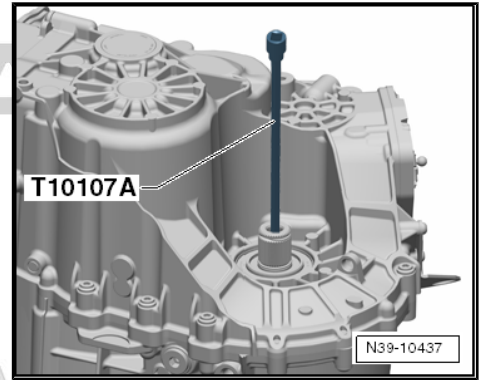

- Pull out rigid shaft gasket ring with multi-purpose tool - MP3-419- and -MP3-419/37- .

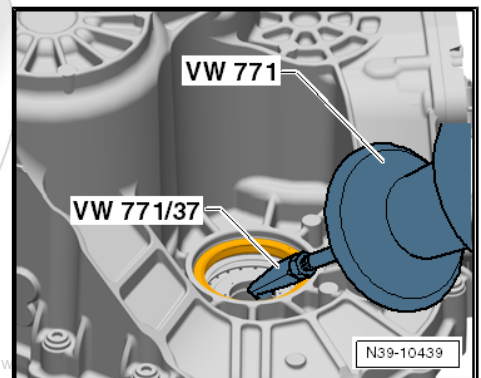

Protected by copyright. Copying for private or commercial purposes, in part or in whole, is prohibited unless authorised by ŠKODA AUTO A. S. ŠKODA AUTO A. S. does not guarantee or accept any liability with respect to the correctness of information in this document. Copyright by ŠKODA AUTO A. S. ©

1.2.2 Install

- Lightly oil new gasket ring at outer surface.
- Fill half the space between the sealing lip and dust lip with sealing grease -G 052 128- .

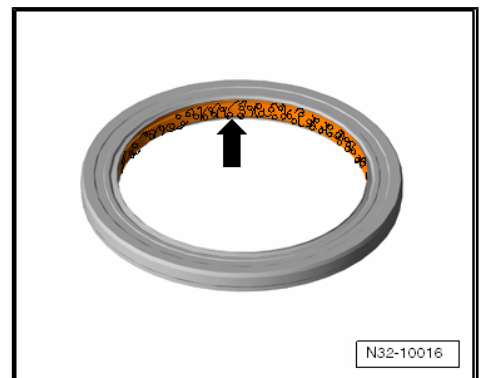

- Drive in the new gasket ring with thrust piece -T30028 (3305)- up to the stop, do not twist the new gasket ring.

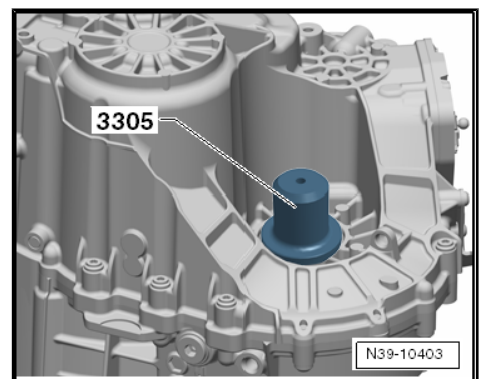



- Replace the O-ring -1- at the rigid shaft.
- Replace the circlip -2- at the rigid shaft.
- Insert rigid shaft.
- Tighten the new conical screw at the rigid shaft to the recommended tightening torque.
- Install left drive shaft ⇒ Chassis ⇒ Rep. Gr. 40 .
- Change gearbox oil ⇒ [page 106](#) .

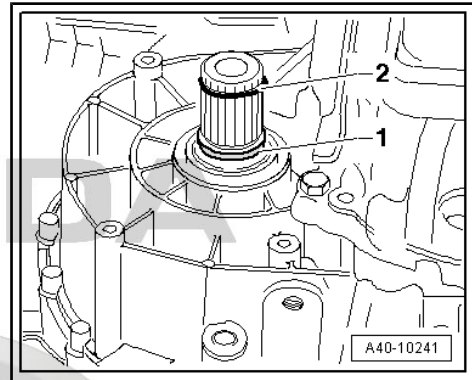

i Note

The gearbox oil must be changed, only in this way the correct gear oil level can be ensured.

- Fit the left front wheel ⇒ Chassis ⇒ Rep. Gr. 44 .
- If the front left vehicle level sensor -G78- was removed, then the headlight beam setting must be checked ⇒ Electrical System ⇒ Rep. Gr. 94 .
- Install the bottom noise insulation ⇒ Body Work ⇒ Rep. Gr. 50 .

Tightening torque

Component	Nm
Rigid shaft on gearbox (conical screw) ¹⁾	⇒ page 110

Protected by copyright. Copying for private or commercial purposes, in part or in whole, is not permitted. ŠKODA AUTO A. S. does not guarantee or accept any liability with respect to the correctness of information in this document. Copyright by ŠKODA AUTO A. S.

1) Always replace conical screw ⇒ **Electronic Catalogue of Original Parts**

1.3 Replacing right rigid shaft gasket ring

Special tools and workshop equipment required

- ◆ Socket insert -T10107 A- or socket insert 6 mm, commercially available
- ◆ Thrust piece -T30028 (3305)-
- ◆ Sealing grease -G 052 128 A1-
- ◆ Catch pan

1.3.1 Removing

i Note

- ◆ *Observe the general repair instructions ⇒ [page 4](#) .*
- ◆ *Do not remove both drive shafts simultaneously from the gearbox. Then it is no longer possible to hold the opposite wheel in order to remove or install the screws of the rigid shafts or flange shafts.*
- ◆ *Do not loosen both fixing screws in the left and right rigid shafts or flange shafts at the same time. If the differential bevel gears twist, it will be difficult to reinstall the screws.*
- Shift selector lever into position "P".
- Remove bottom noise insulation ⇒ Body Work ⇒ Rep. Gr. 50 .

- Remove the screen cap for the right drive shaft from the engine -arrows-.

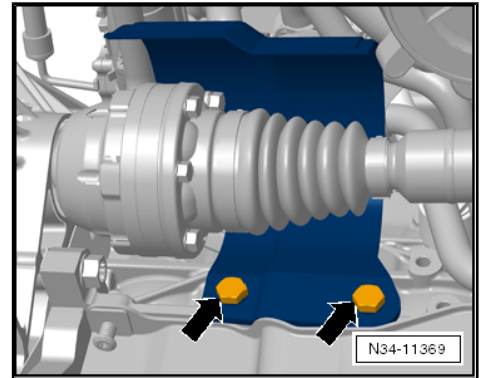

- Unscrew the nuts -arrows- from the steering joint to the right track control arm.
- Unhook the steering joint from the track control arm.

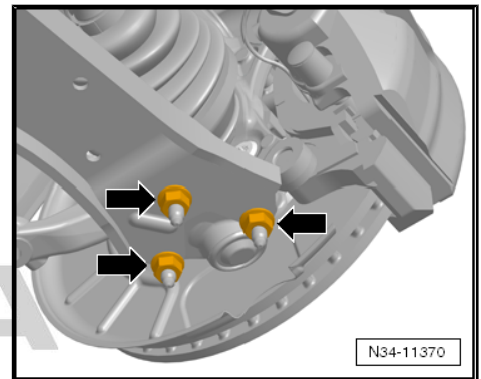

 **Note**

- ◆ *It is not necessary to slacken the screw connection of the drive shaft on the wheel side.*
- ◆ *The drive shaft must not be removed, it is sufficient to tie it up.*
- ◆ *The drive shaft must not hang down, because overstretching will cause damage to the inner joint.*

- Press off the drive shaft from the rigid shaft of the gearbox e.g. using a tyre iron.
- Tie up the drive shaft as far as possible. Avoid damaging the paintwork on the drive shaft during this operation.
- Position the catch pan under the gearbox.

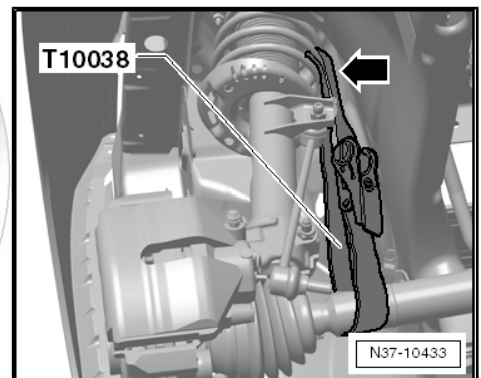

- Release screw -arrow- in the rigid shaft with° socket wrench - T10107 A- or commercially available 6°mm socket wrench.
- Pull out rigid shaft.
- Remove the gasket ring of the rigid shaft e.g with ejection hook -T20143- or tyre iron.

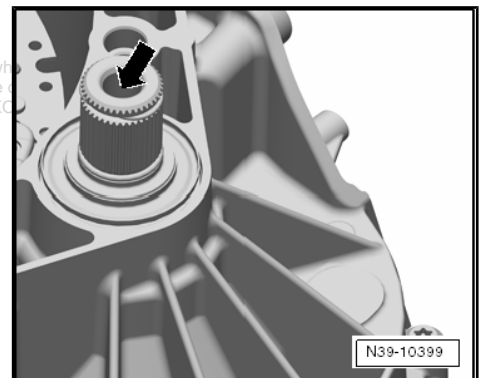

1.3.2 Install

- Lightly oil new gasket ring at outer surface.



- Fill half the space between the sealing lip and dust lip with sealing grease -G 052 128- .

i Note

- ◆ Do not press in gasket ring with pressure plate -T30028 (3305)- up to the stop!
- ◆ The shaft seal reaches its stop in the gearbox before the pressure plate -T30028 (3305)- .
- ◆ The pressure plate -T30028 (3305)- can therefore not be type-punched up to the stop of the tool.

- Drive in the new gasket ring up to the stop, to do so do not tilt the gasket ring.

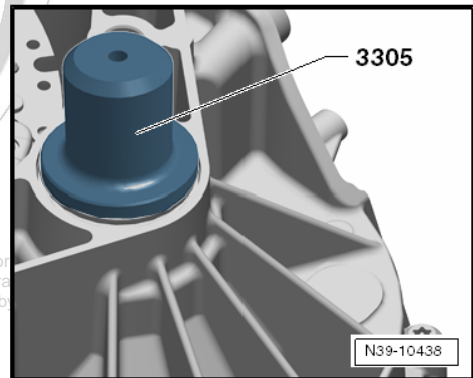
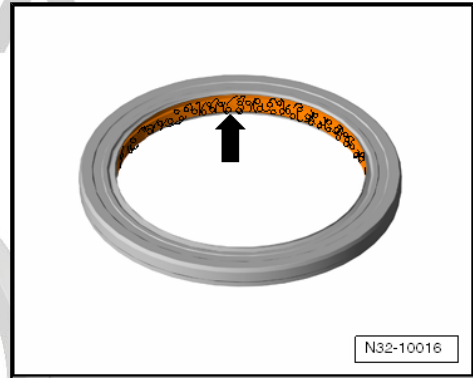

Protected by copyright. Copying for private or commercial purposes, in part or unless authorised by ŠKODA AUTO A. S. ŠKODA AUTO A. S. does not guarantee with respect to the correctness of information in this document. Copyright by

- Replace the O-ring -1- at the rigid shaft.
- Replace the circlip -2- at the rigid shaft.
- Insert rigid shaft.
- Tighten the new conical screw at the rigid shaft to the recommended tightening torque.
- Press the right drive shaft onto the rigid shaft of the gearbox until the circlip locks in place ⇒ Chassis ⇒ Rep. Gr. 40 .

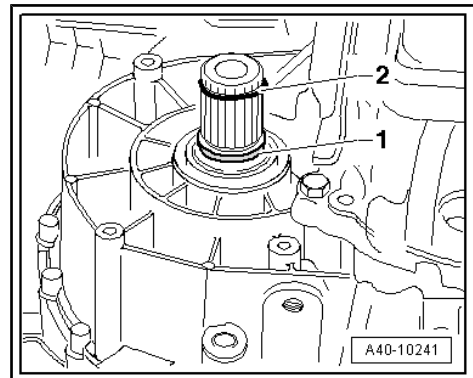

- Screw the steering joint to the track control arm -arrows- ⇒ Chassis ⇒ Rep. Gr. 40 .

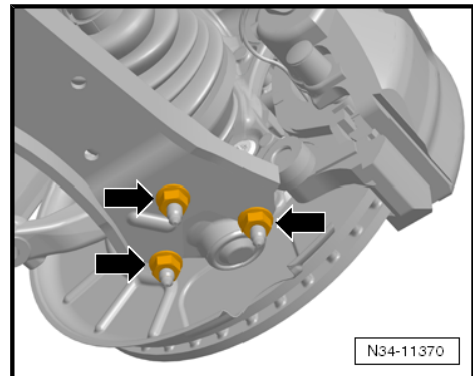

- Install screen cap for right drive shaft on the engine -arrows-
⇒ Chassis ⇒ Rep. Gr. 40 .
- Change gearbox oil ⇒ [page 106](#) .

i Note

The gearbox oil must be changed, only in this way the correct gear oil level can be ensured.

- Install the bottom noise insulation ⇒ Body Work ⇒ Rep. Gr. 50 .

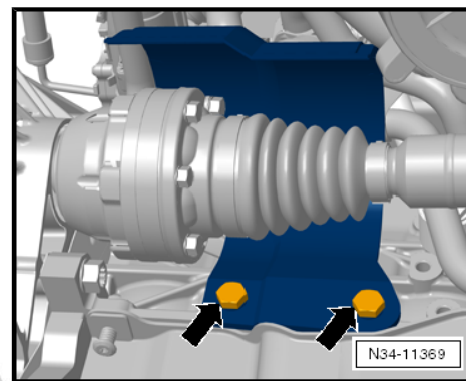

Tightening torques

Component	Nm
Rigid shaft on gearbox (conical screw) ¹⁾	⇒ page 110
Screen cap/drive shaft to engine	35 Nm

¹⁾ Always replace conical screw ⇒ Electronic Catalogue of Original Parts

1.4 Replacing the left flange shaft gasket ring

Special tools and workshop equipment required

- ◆ Multi-purpose tool -MP3-419 (VW 771)-
- ◆ Extractor -MP3-419/37 (VW 771/37)-
- ◆ Socket insert -T10107 A- or socket insert 6 mm, commercially available
- ◆ Thrust piece -T30028 (3305)-
- ◆ Tensioning strap -T10038-
- ◆ Sealing grease -G 052 128 A1-
- ◆ Catch pan

1.4.1 Removing

i Note

- ◆ *Observe the general repair instructions ⇒ [page 4](#) .*
- ◆ *Do not remove both drive shafts simultaneously from the gearbox. Then it is no longer possible to hold the opposite wheel in order to remove or install the screws of the rigid shafts or flange shafts.*
- ◆ *Do not loosen both fixing screws in the left and right rigid shafts or flange shafts at the same time. If the differential bevel gears twist, it will be difficult to reinstall the screws.*

- Loosen the front left wheel bolts.
- Raise vehicle.
- Unscrew the front left wheel.
- Remove bottom noise insulation ⇒ Body Work ⇒ Rep. Gr. 50 .



- Remove coupling rod from anti-roll bar.
- If present, remove front left vehicle level sensor -G78- .
- Remove left drive shaft from flange shaft ⇒ Chassis ⇒ Rep. Gr. 40 .

i Note

The drive shaft must not hang down, because overstretching will cause damage to the inner joint.

- Tie up the drive shaft as far as possible. Avoid damaging the paintwork on the drive shaft during this operation.
- Position the catch pan under the gearbox.

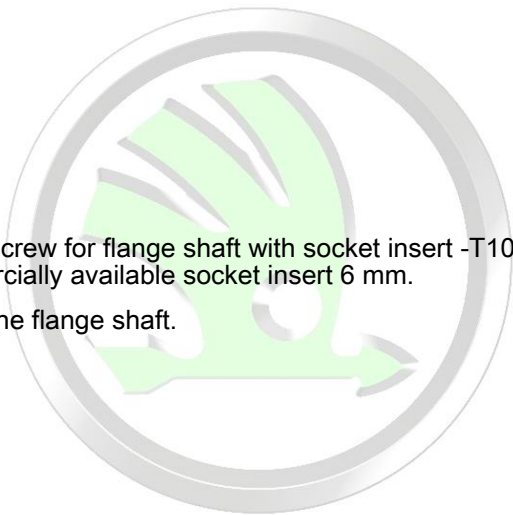

- Unscrew screw for flange shaft with socket insert -T10107 A- or commercially available socket insert 6 mm.
- Take out the flange shaft.

Protected by copyright. Copying for private or commercial purposes, in part or in whole, is not permitted unless authorised by ŠKODA AUTO A. S. ŠKODA AUTO A. S. does not guarantee or accept any liability with respect to the correctness of information in this document. Copyright by ŠKODA AUTO A. S. ©

- Pull out rigid shaft gasket ring with multi-purpose tool - VW 771- and -MP3-419/37- .

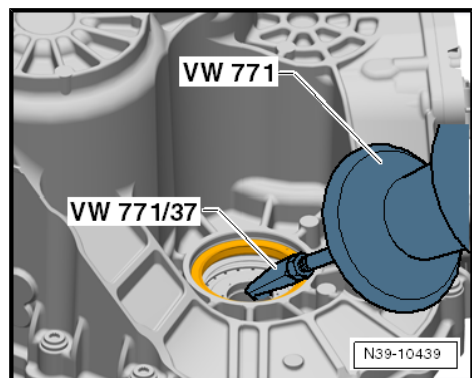
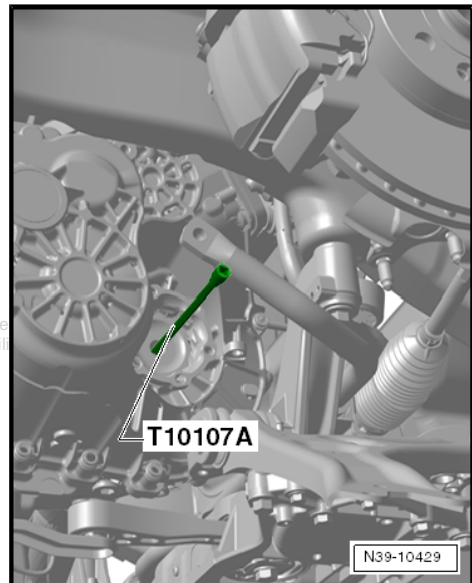
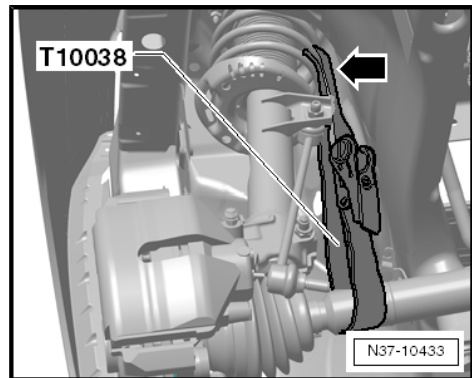
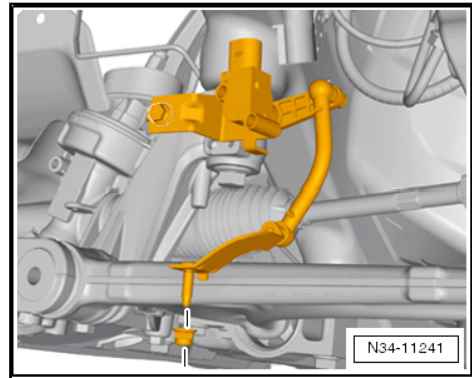

1.4.2 Install

- Lightly oil new gasket ring at outer surface.
- Fill half the space between the sealing lip and dust lip with sealing grease -G 052 128- .

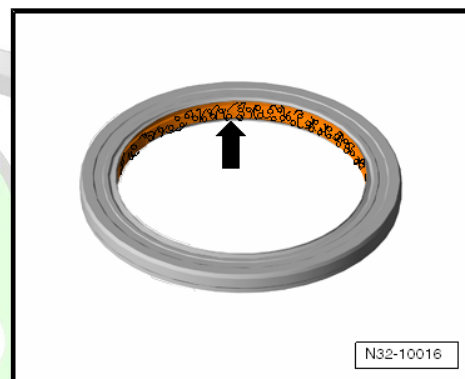

- Drive in the new gasket ring with thrust piece -T30028 (3305)- up to the stop, do not twist the new gasket ring.
- Insert the flange shaft.
- Tighten new conical screw to the recommended tightening torque.
- Attach the left drive shaft to the flange shaft ⇒ Chassis ⇒ Rep. Gr. 40 .
- Change gearbox oil ⇒ [page 106](#) .

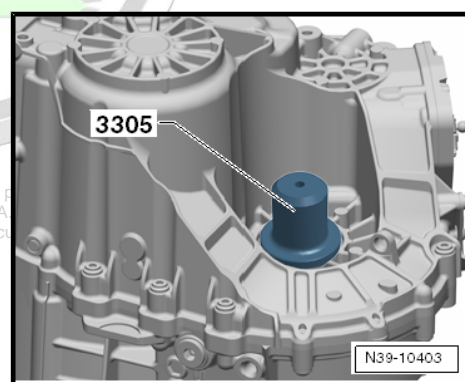

i Note

The gearbox oil must be changed, only in this way the correct gear oil level can be ensured.

- Fit the left front wheel ⇒ Chassis ⇒ Rep. Gr. 44 .
- If the front left vehicle level sensor -G78- was removed, then the headlight beam setting must be checked ⇒ Electrical System ⇒ Rep. Gr. 94 .
- Install the bottom noise insulation ⇒ Body Work ⇒ Rep. Gr. 50 .

Tightening torque

Component	Nm
Rigid shaft on gearbox (conical screw) ¹⁾	⇒ page 110

¹⁾ Always replace conical screw ⇒ Electronic Catalogue of Original Parts

1.5 Replacing the right flange shaft seal ring

Special tools and workshop equipment required

- ◆ Socket insert -T10107 A- or socket insert 6 mm, commercially available
- ◆ Extractor -T20143-
- ◆ Thrust piece -T30028 (3305)-
- ◆ Tensioning strap -T10038-
- ◆ Sealing grease -G 052 128 A1-



- ◆ Catch pan

1.5.1 Removing

i Note

- ◆ Observe the general repair instructions ⇒ [page 4](#) .
- ◆ Do not remove both drive shafts simultaneously from the gearbox. Then it is no longer possible to hold the opposite wheel in order to remove or install the screws of the rigid shafts or flange shafts.
- ◆ Do not loosen both fixing screws in the left and right rigid shafts or flange shafts at the same time. If the differential bevel gears twist, it will be difficult to reinstall the screws.

- Shift selector lever into position "P".
- Remove bottom noise insulation ⇒ Body Work ⇒ Rep. Gr. 50 .
- Remove the screen cap for the right drive shaft from the engine -arrows-.
- Remove right drive shaft from flange shaft ⇒ Chassis ⇒ Rep. Gr. 40 .

i Note

The drive shaft must not hang down, because overstretching will cause damage to the inner joint.

- Tie up the drive shaft as far as possible. Avoid damaging the paintwork on the drive shaft during this operation.
- Position the catch pan under the gearbox.

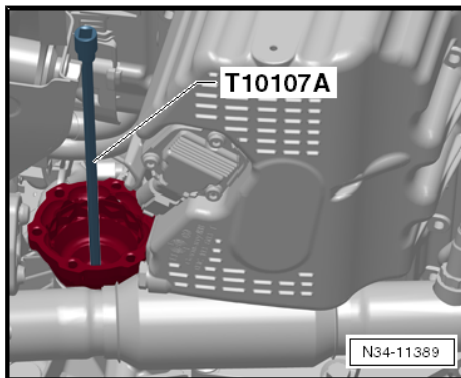
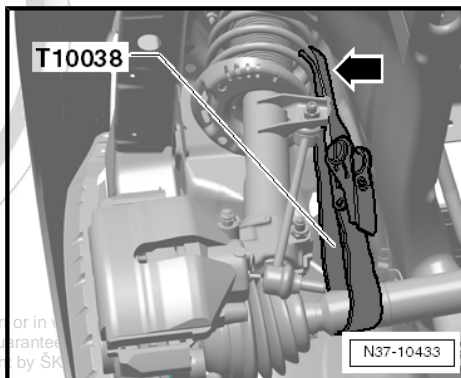
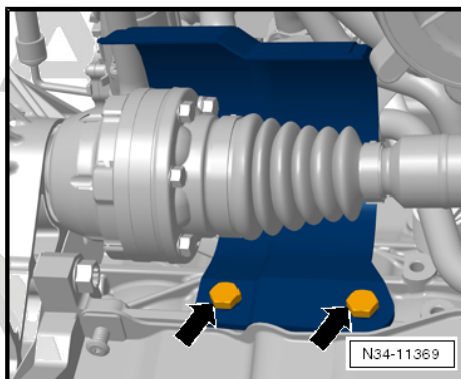

- Unscrew screw for flange shaft with socket insert -T10107 A- or commercially available socket insert 6 mm.
- Take out the flange shaft.
- Remove the gasket ring of the rigid shaft e.g with ejection hook -T20143- or tyre iron.

Protected by copyright. Copying for private or commercial purposes, in part or in full, is prohibited unless authorised by ŠKODA AUTO A. S. ŠKODA AUTO A. S. does not guarantee the accuracy of information with respect to the correctness of information in this document. Copyright © ŠKODA AUTO A. S.

1.5.2 Install

- Lightly oil new gasket ring at outer surface.
- Fill half the space between the sealing lip and dust lip with sealing grease -G 052 128- .

 **Note**

- ◆ *Do not press in gasket ring with pressure plate -T30028 (3305)- up to the stop!*
- ◆ *The shaft seal reaches its stop in the gearbox before the pressure plate -T30028 (3305)- .*
- ◆ *The pressure plate -T30028 (3305)- can therefore not be type-punched up to the stop of the tool.*

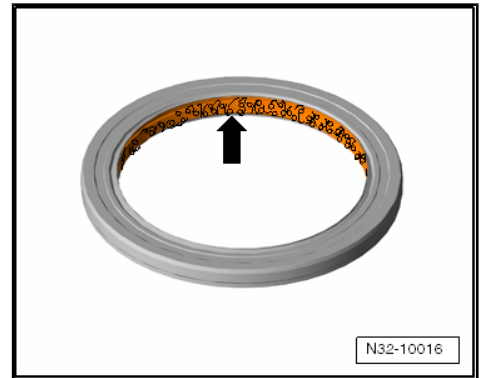

- Drive in the new gasket ring up to the stop, to do so do not tilt the gasket ring.
- Insert the flange shaft.
- Tighten new conical screw to the recommended tightening torque.
- Fit the right drive shaft to the flange shaft ⇒ Chassis ⇒ Rep. Gr. 40 .

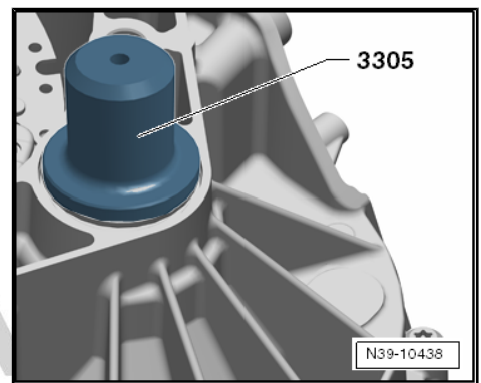

- Install screen cap for right drive shaft on the engine -arrows- ⇒ Chassis ⇒ Rep. Gr. 40 .
- Change gearbox oil ⇒ [page 106](#) .

 **Note**

The gearbox oil must be changed, only in this way the correct gear oil level can be ensured.

- Install the bottom noise insulation ⇒ Body Work ⇒ Rep. Gr. 50 .

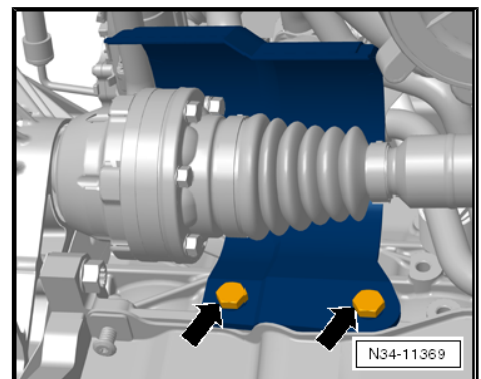

Tightening torques

Component	Nm
Flange shaft on gearbox (conical screw) 1)	⇒ page 110
Screen cap/drive shaft to engine	35 Nm

1) Always replace conical screw ⇒ [Electronic Catalogue of Original Parts](#)